

Ver-2026

MAIN CATALOGUE

SELUX

NC TOOLING SYSTEM
FOR MACHINING CENTER



SEKWANG SELUX CO., LTD.

SELUX
NC TOOLING SYSTEM

NC TOOLING SYSTEM FOR MACHINING CENTER

Ver. 2026

SEKWANG SELUX CO., LTD. as a manufacturer specialized in the production of machining center tool has pursued customer emotion through a competitive technology and quality. Also, we will try constantly to develop 21th century Tooling System through persistent technical improvements with new challenge and target named Global Market Leader.

(주) 세광세럭스는 머시닝센터 툴 전문 메이커로서
기술경쟁력, 품질경쟁력을 통하여 고객 감동을 추구하는 서비스로
Global Market Leader 기업 달성의 새로운 도전과 목표를 향하여 지속적인
기술 혁신을 통한 21세기 툴링 시스템 개발을 위해 부단히노력할 것입니다.





COMPANY HISTORY

- | | |
|-----------------------------------|---|
| 197904 세광정밀 설립 | Mar1979 Established Sekwang Precision Manufacture. |
| 198604 Straight Collet 생산 | Apr1986 Products Straight Collet. |
| 2001 05 Tooling System 생산 | May2001 Products Tooling System. |
| 200310 부천공장 이전 | Oct2003 Moved in Bucheon Factory. |
| 200704 (주)세광으로 상호변경 | Apr2007 Changed the firm name as Sekwang co., Ltd |
| 200805 SC Collet 개발 | May2008 Developed & Produced SC Collet. |
| 200912 ISO/TS 16949 : 2009 인증취득 | Dec2009 Acquired ISO/TS 16949 : 2009 certificate. |
| 201002 HSK Tooling System 개발 | Feb2010 Products HSK Tooling System. |
| 201105 연구소설립 | May2011 Estdlished Laboratory. |
| 201109 SELUX 상표등록 | Sep2011 Register SELUX Brand. |
| 201206 부천 도당동 공장으로 확장 이전 | June2012 Moved in Extended Factory. |
| 201404 국내/외 전시회 출품시작 | Apr2014 Join the Local and oversea exhibition. |
| 201412 GBT 이면구속 Tooling System 개발 | Dec2014 Products GBT two face contact Tooling System. |
| 201504 열박음척 개발 | Apr2015 Products SHRINK FIT Tooling System. |
| 201711 현 공장으로 확장이전 | Nov2017 Moved in Extended Factory. |
| 201712 (주)세광 세룩스로 사명변경 | Dec 2017 Changed the firm name as Sekwang selux co.,Ltd |
| 202003 Endmill Collet Chuck 개발 | Apr2020 Products Endmill Collet Chuck |
| Synchro Tapping Chuck 개발 | Products Synchro Tapping Chuck |
| Coolant K Collet 개발 | Products Coolant K Collet |

INDEX

NC TOTAL TOOLING SYSTEM **SELUX**

HYDRAULIC CHUCK



High Precision Run-out Accuracy

D p138~139

Clamping Range :
Ø3.0 ~ Ø32.0

GBT SHANK	18~19
BT SHANK	42~43
HSK SHANK	82~83
SK SHANK	102

MILLING CHUCK



Powerful Chucking Force

MAX
520kg f.m

K p140

Clamping Range :
Ø3.0 ~ Ø42.0

GBT SHANK	20
BT SHANK	44~45
HSK SHANK	84
SK SHANK	103
NT/MT SHANK	114~116

HIGH SPEED MILLING CHUCK



Excellent Run-out Accuracy

K p140

Clamping Range :
Ø3.0 ~ Ø32.0

GBT SHANK	21
BT SHANK	46
HSK SHANK	85

SHRINK FIT HOLDER

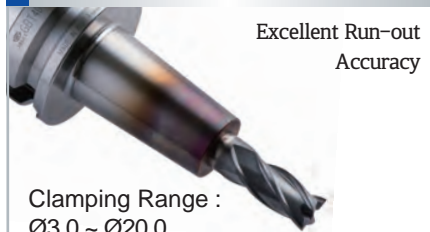

Excellent Run-out Accuracy

Clamping Range :
Ø3.0 ~ Ø20.0

GBT SHANK	22~23
BT SHANK	48~49
HSK SHANK	86~88
SK SHANK	104
ST SHANK	126~127
ACCESSORY	153

SSK COLLET CHUCK

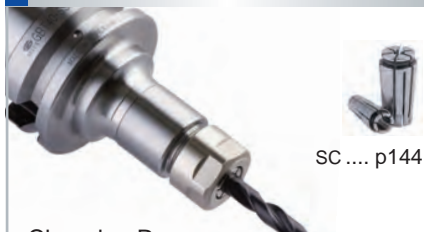

SC p144

Clamping Range :
Ø1.0 ~ Ø25.4

GBT SHANK	24~25
BT SHANK	50~51
HSK SHANK	89
SK SHANK	105
ST SHANK	124~125

HIGH SPEED GSK CHUCK (P CLASS)



SC p144

Clamping Range :
Ø1.0 ~ Ø25.4

GBT SHANK	26~27
BT SHANK	52~53
HSK SHANK	90~91

ER COLLET CHUCK

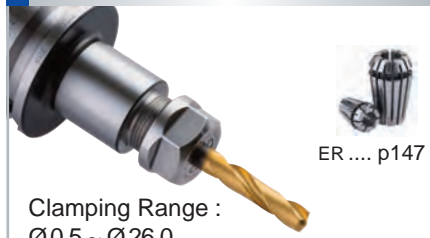

ER p147

Clamping Range :
Ø0.5 ~ Ø26.0

GBT SHANK	28
BT SHANK	54~55
HSK SHANK	92
SK SHANK	106
NT/MT SHANK	117~119
ST SHANK	128~129

ENDMILL COLLET CHUCK



SE p146

Clamping Range :
Ø6 ~ Ø20

GBT SHANK	29
BT SHANK	56
HSK SHANK	93

ER SLIM COLLET CHUCK



ER p146

Clamping Range :
Ø0.5 ~ Ø16.0

BT SHANK	57
ST SHANK	130

SYNCHRO TAPPING CHUCK



GBT SHANK	30
BT SHANK	58
HSK SHANK	94

TAPPING CHUCK



Clamping Range :
M3 ~ M36

GBT SHANK	31
BT SHANK	59
HSK SHANK	95
SK SHANK	108
ST SHANK	133

NC DRILL CHUCK



Clamping Range :
Ø0.3 ~ Ø13.0

GBT SHANK	32
BT SHANK	60
HSK SHANK	96
SK SHANK	107
NT/MT SHANK	120
ST SHANK	132

SIDE LOCK HOLDER



Clamping Range :
Ø6.0 ~ Ø42.0

GBT SHANK	33
BT SHANK	61~64
HSK SHANK	97
SK SHANK	109
NT/MT SHANK	120

MOLD SIDE LOCK HOLDER



Clamping Range :
Ø3.0 ~ Ø32.0

GBT SHANK	34
BT SHANK	65

JACOBS TAPER ARBOR



BT SHANK	66
SK SHANK	108

MORSE TAPER HOLDER



■ for Morse taper shank with tang.

**TAPER 접촉율
80% 이상 진동없음.**

GBT SHANK	35
BT SHANK	67,68
HSK SHANK	98
SK SHANK	111

FACE MILL ARBOR



GBT SHANK	36~38
BT SHANK	69~75
HSK SHANK	99~100
SK SHANK	112
NT/MT SHANK	121~122
ST SHANK	134~135

PRO MILL ARBOR



GBT SHANK	39
BT SHANK	76
SK SHANK	110
ST SHANK	136

INDEX

SIDE CUTTER ARBOR



GBT SHANK 40
BT SHANK 77

SQUARE BORING BAR



Boring Range :
Ø25.0 ~ Ø260.0
BT SHANK 79~80

GYRO CHUCK



※ CNC 편심조정!!

Clamping Range :
Ø0.5 ~ Ø16.0
ST SHANK 131

FLOATING ER TAP CHUCK



Clamping Range :
Ø0.5 ~ Ø20.0
※ CNC 선반 TAP작업시 능률 UP!!
ST SHANK 133

TEST BAR



ACCESSORY 150

BLANK TOOL



ACCESSORY 151

ACCESSORY



COOLANT PIPE 100



ACCESSORY .. 153



ACCESSORY.. 154

UNIVERSAL
MAGNETIC BASE
..... 154



SPINDLE CLEANER 155



TOUCH POINT SENSOR 155



HEIGHT ORESETER 156



ZOP-50..... 156



SPANNER / GH SPANNER..... 157



PULL STUD BOLT .. 158

D'ANDREA MODULAR BORING SYSTEM

BASIC HOLDER 172-187



HSK-A



HSK-E



HSK-F



HSK-A



CAPTO



KM



SK FACE CONTACT



BT FACE CONTACT



DIN 69871



MAS403 BT



ST

TS



Rough

D'ANDREA 190-195

TRD



Rough/Semi finishing

D'ANDREA 196-199

TRC



Finishing

D'ANDREA 200-215

TRM



Super finishing

D'ANDREA 222-241

TR-ELETTRA



Super finishing

D'ANDREA 242-243

BPS



Large Bore boring
Rough/Super finishing

D'ANDREA 244-253

GBT TOOLING SYSTEM

Product is Simple, Quality is not Simple

SELUX
NC TOOLING SYSTEM



	BT	GBT
BT 50	ø 69.85	ø100
BT 40	ø 44.45	ø 63
BT 30	ø 31.75	ø 46

Basic Concept

GBT 이면구속 시스템은 표준 BT타입을 기반으로한 가장최신 기술입니다.

The GBT Dual Contact System is based on the most current available standards in BT (JIS B6339).

일반 테이퍼 홀더는 게이지 라인의 직경을 기준으로 스펀들에 접촉되어 사용되지만 GBT 홀더는 플랜지 면의 직경을 기준으로 접촉되어 스펀들 장착에 기존 테이퍼의 홀더보다 우수한 내구성 및 가공성의 효과를 가지고 있습니다.

A conventional steep taper toolholder is supported on a reference diameter called the gauge face. On the contrary, a GBT toolholder is supported on the flange face, which brings remarkable improvement to rigidity.

INCREASED CONTACT DIAMETER (Example of BT)

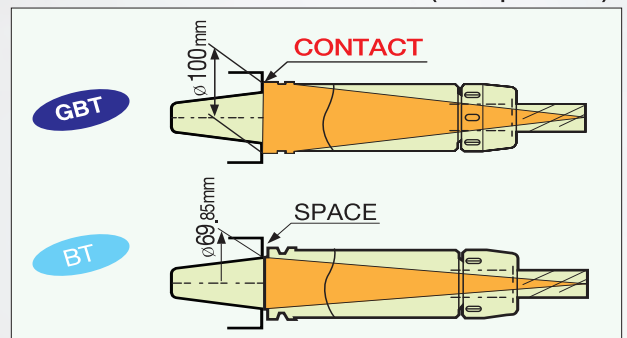

Perfect Interchangeability

GBT는 일반 표준 스펀들의 장비에서 사용될수 있습니다.

GBT toolholder can be used on existing standard machine spindles.

표준 툴 홀더들은 이면구속 스펀들에서 사용 될수 있습니다.

Existing standard toolholders can also be used on dual contact spindles.

이러한 경우, 동시 접촉 즉 이면구속의 효과는 없습니다.

In this case, simultaneous contact cannot be attained.

다른 동시 접촉 시스템은 이면구속 툴 홀더, 툴프리셋터, 툴크램프 등의 별도의 약세사리들을 요구하지만 GBT 이면구속 스펀들은 현재 사용중인 BT 타입의 약세사리들을 사용가능하며 사용중인 머신닝센터의 툴 메거진과 ATC를 개조할 필요 없이 사용가능합니다.

Although other simultaneous contact systems require exclusive new accessories, the dual contact spindle uses existing accessories such as a presetter and toolholder fixture.

It is not necessary to modify tool magazines and ATC devices of existing machines.

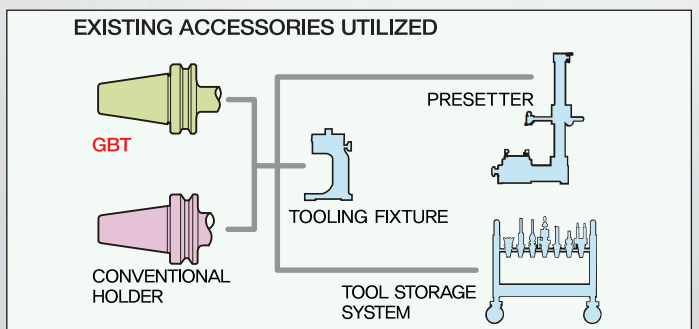
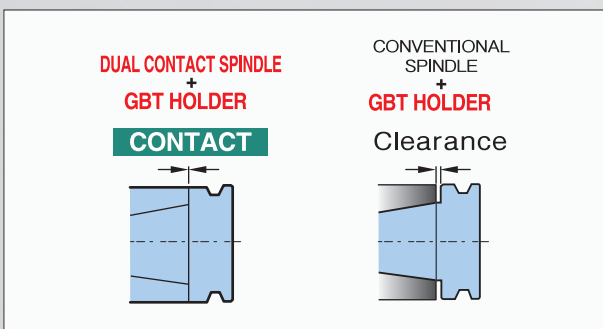

HSK TOOLING SYSTEM

Product is Simple, Quality is not Simple

SELUX
NC TOOLING SYSTEM



HSK Shank perfect two-surface constrained system

2면 구속형 HSK Shank

Connecting

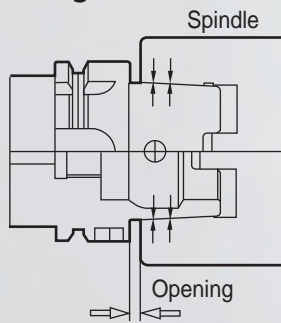

Elastic deformation of taper makes flange surface closely contact the spindle.

Taper의 탄성변형이 Flange 단면에 Spindle에 밀착시킴

Clamping

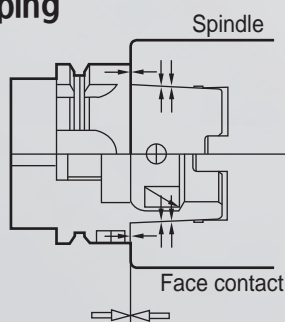

HIGH RIGIDITY AGAINST BENDING LOAD

Holder의 Taper가 Spindle의 형상 측면에 따라 유연하게 변경되므로 Spindle과 Holder 사이에 편심력이 없게 한다.

Two surface (taper and flange) constrained tool interface utilizing appropriate contact pressure distribution and elastic deformation of the taper has an extraordinary bending, strength and stand with heavy cutting with long projection length.

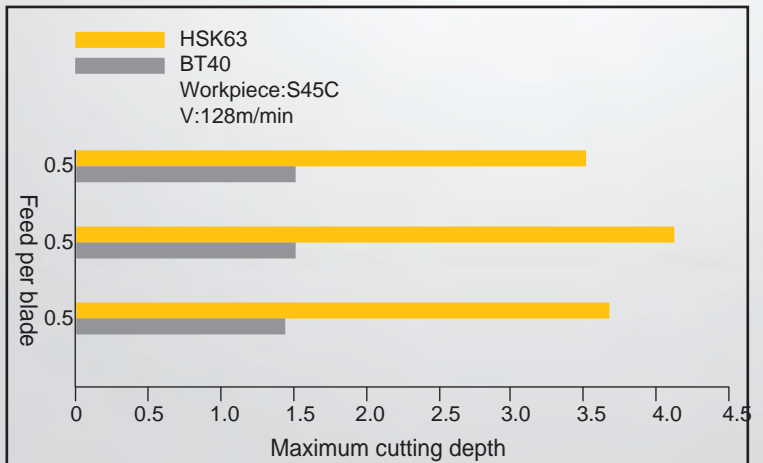
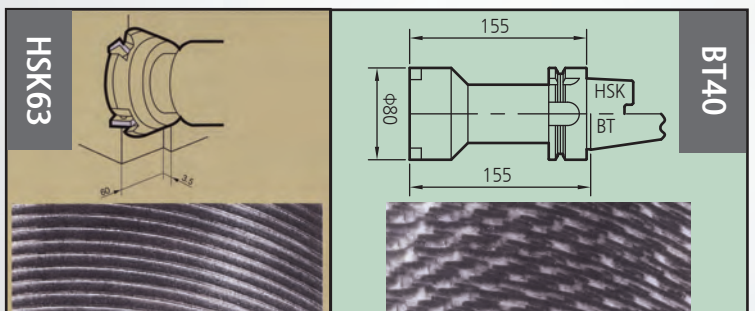

MILLING CHUCK

Product is Simple, Quality is not Simple

SELUX
NC TOOLING SYSTEM



Excellent Runout Accuracy

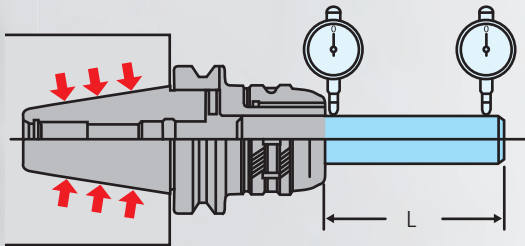

3.5D 선단에서 5 μ m(T.I.R)이내의 흔들림 정도, 단면 밀착으로 진동을 흡수하여 최적의 절삭을 할수 있도록 제작되었습니다.

5 μ m(T.I.R) RUN-OUT at 3.5D away from shank nose.
Two face contact cause to be the optimal cutting operation because of vibrational absorption.

Clamping Torque Test Data

Model	Troque kg f.m
MC20	120
MC25	170
MC4032	250
MC5032	350
MC5042	500

(SKP)	When oil removed completely with thinner cleanly
MC20	130kg f.m
MC25	180kg f.m
MC4032	260kg f.m
MC5032	360kg f.m
MC5042	520kg f.m

High Chucking Accuracy

SELUX 밀링척은 평균 2회전 안으로 척킹/언척킹이 가능하도록 제작되었습니다. SELUX MILLING CHUCK is chucking and unchucking just with 2 revolution 바디와 CAP부분 O-RING을 부착하여 진동을 방지하고 CAP내부 Retainer와 Roller를 보호하여 뛰어난 내구성을 자랑합니다.

As it has "O-RING" between body of milling chuck and CAP, SELUX MILLING CHUCK do not have vibration and has extreme rigidity.

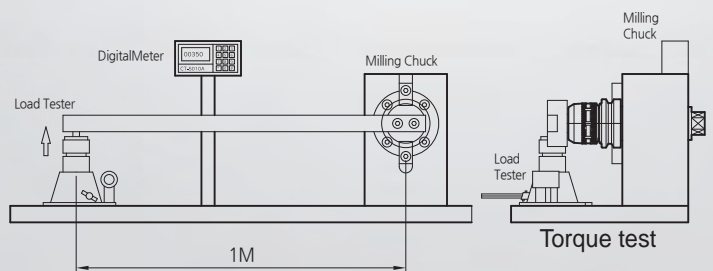
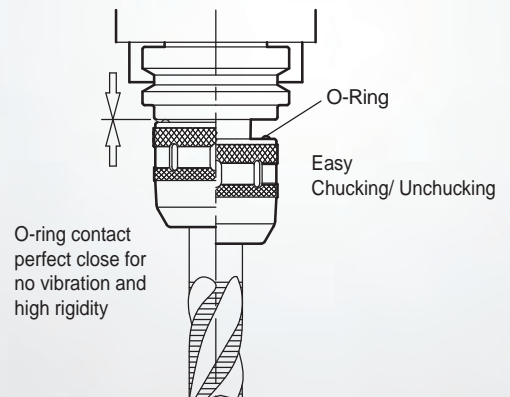

Product is Simple, Quality is not Simple

SELUX
NC TOOLING SYSTEM



Collet

Excellent Runout Accuracy

SELUX 유압척은 4D x 3 μ m(T.I.R) 이내의 흔들림 정도를 보장하며 고속가공에 최적화되어 설계되었습니다.
(max. G2.5 at 25000rpm)

SELUX HYDRAULIC CHUCK ensure high precision runout accuracy is less than 3 μ m at 4D (T.I.R) and has been designed and optimized for high speed machining.
(Max G2.5 at 25,000 rpm)

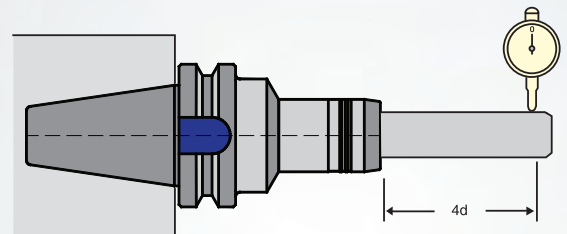

Clamping Torque Test Data

\varnothing	N.m	\varnothing	N.m	\varnothing	N.m	\varnothing	N.m	\varnothing	N.m
6	16	10	45	14	110	18	240	25	400
8	23	12	95	16	185	20	330	32	650



Easy chucking system

SELUX 유압척은 T-Wrench 하나로 쉽게 클램핑/언클램핑이 가능하며 사용시 공구교환이 쉽고 빠르게 하여 작업성 향상에 적합한 제품입니다.

SELUX HYDRAULIC CHUCK can be easy clamp and unclamp using just one T-Wrench and very convenient to exchange cutting tools.

Variety Use

SELUX 유압척은 정밀 정삭/사상 작업에 적합한 공구로 다양한 사용범위를 자랑합니다.

SELUX HYDRAULIC CHUCK boast a wide variety of uses as holder for precision finishing operation.

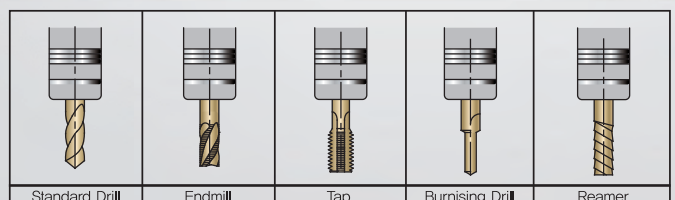

SELUX SSK COLLET CHUCK

Product is Simple, Quality is not Simple

SELUX
NC TOOLING SYSTEM



Excellent Run-out Accuracy

(All grounded collet chuck for speed and high accuracy.)

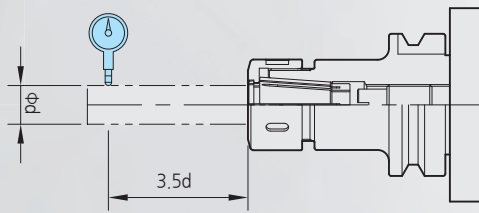

Style & ϕd	T.I.R(μm)	
	Stated	P class
SC 6 - ϕd	0.005	0.003
SC10 - ϕd		
SC13 - ϕd		
SC16 - ϕd		
SC20 - ϕd		
SC25 - ϕd		

정직한 RUN-OUT 결과를 보증하는 SELUX SSK COLLET CHUCK은 정밀가공에 최적화된 제품입니다.
SELUX SSK COLLET CHUCK that guarantee accuracy RUN-OUT is optimal product for precision operation.

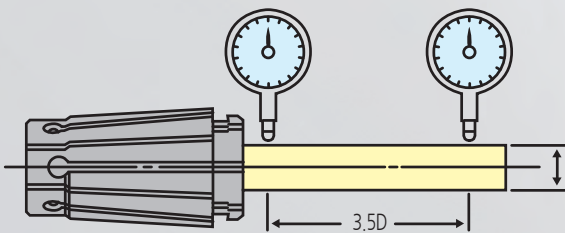

3.5D 선단에서 표준 5 μm , 정밀급 3 μm 을 전수검사로 보증합니다.
The standard is 5 μm (T.I.R) RUN-OUT and P CLASS is 3 μm (T.I.R) RUN-OUT at 3.5D away from shank nose.
(We inspect all of the collet)

SELUX SSK COLLET CHUCK은 엔드밀, 드릴, 리머 등 다양한 가공에 적합하게 제작되었습니다.

SELUX SSK COLLET CHUCK is suitable for a various operation using drill, endmill and reamer

GSK COLLET CHUCK

MAX
40,000
min⁻¹

Coolant-through hole
Clamping Range : $\phi 1.0 \sim \phi 25.4$



- 고속가공에서 높은 정도
- 8Taper의 강력한 파지력
- 원형 너트로 컴팩트한 디자인
- 스패너는 PH스패너 사용(별매)
- G2.5X max 40,000 RPM
- 고속형GSK척에는 P CLASS 콜릿 사용을 권장

SHRINK FIT HOLDER

Product is Simple, Quality is not Simple

SELUX
NC TOOLING SYSTEM



Easy chucking

Power Clamping

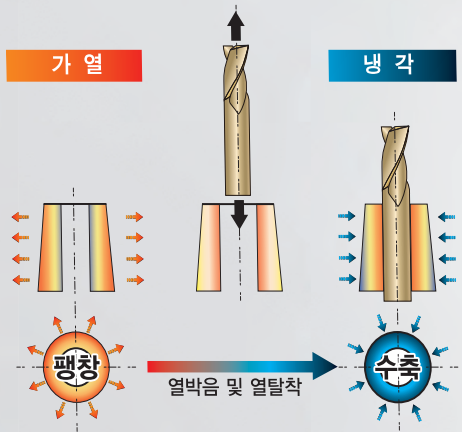

	SHRINK FIT	Collet Holder
Chucking System 척킹원리	홀더의 열팽창을 이용한 열박음 시스템 The shrink fit system is based on Thermal expansion of the shrink fit holder	콜릿의 탄성으로 공구를 고정하는 시스템 The system to Clamp cutting tool using elastic collet
Chanking force 열팽창을(ø6)	6.2 kgf.m	2.1kgf.m
	 열팽창을 ▶ 수축력	 탄성변형

Optimal operation with slim and symmetrical design

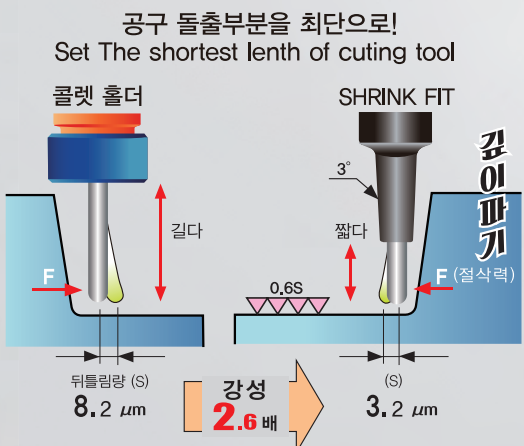

길이조정 자유자재, 완벽한 접근성.

Easy to adjust tool length, perfect operation accessibility

스트레이트 타입은 필요에 따라 길이를 조정할 수 있습니다.

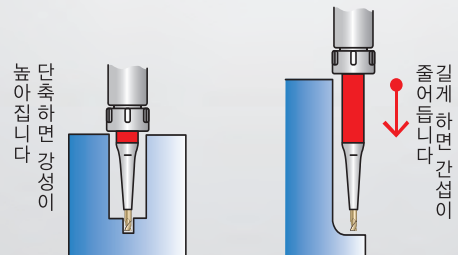

Straight Type

Product is Simple, Quality is not Simple

SELUX
NC TOOLING SYSTEM



Excellent Runout Accuracy

SELUX END MILL COLLET CHUCK은 $4D \times 5\mu\text{m}$ (T.I.R) 이내의 RUN-OUT을 보장 (max. G6.3 at 10,000rpm)
SELUX END MILL COLLET CHUCK ensure high precision runout accuracy is less than $5\mu\text{m}$ at $4D$ (T.I.R) (Max G2.5 at 20,000 rpm)

SELUX END MILL COLLET CHUCK은 SELUX 전용 콜릿, SE COLLET을 사용하고 SE COLLET은 전수 검사를 통해 $4D \times 5\mu\text{m}$ (T.I.R) 이 내의 RUN-OUT 보증

SELUX END MILL COLLET CHUCK can use only SELUX SE COLLET.
SELUX SE COLLET is not compatible with other collet chuck.
We inspect all SE COLLETS and garrantee accuracy $4D \times 5\mu\text{m}$ (T.I.R)

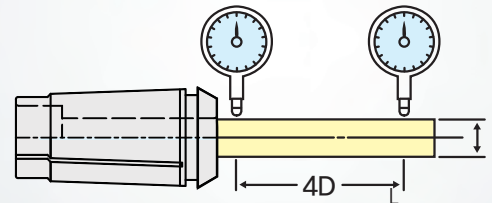
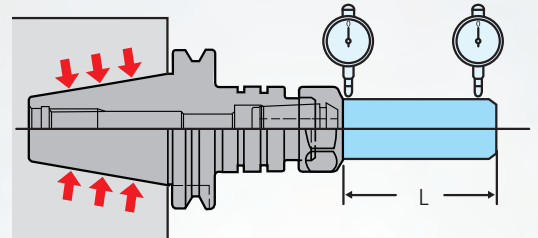

Strong Clamping (Grip) Power

SELUX SE COLLET CHUCK은 낮은 각도와 넓은 접촉면으로 설계되어 기존 COLLET CHUCK 보다 강력한 파지력으로 가공 가능합니다.
It has a lower angle and contact surface than the existing ER scale, showing up to 2 times the amount of ground strength

Clamping Torque Test Data

Model	Troque		Model	Troque		Model	Troque	
	Nm			Nm			Nm	
ER20	50		ER25	70		ER32	140	
SK13	60		SK16	120		SK20	120	
SE20	120		SE25	148		SE32	180	

※스패너는 ER척과 공용으로 사용가능 합니다.

Product is Simple, Quality is not Simple

SELUX
NC TOOLING SYSTEM



Excellent Balance

SELUX SYNCHRO TAPPING 척은 4D x 25 μ m(T.I.R) 이내의 흔들림 정도를 보장하며 고속가공 최적화된 제품입니다. (max. G6.3 at 10,000rpm)
SELUX SYNCHRO TAPPING CHUCK ensure high precision runout accuracy is less than 25 μ m at 4D (T.I.R) and has been designed and optimized for high speed. (Max G6.3 at 10,000 rpm)

SELUX만의 특수 설계(특허보유)로 인한 0.01이하의 미세 상하 플로팅 기능 및 5도 이하의 좌/우 움직임 기능으로 기존 TAPPING 작업 대비 30% 이상의 원가 절감 가능합니다. (생산성 향상 및 공구 수명 연장)
SELUX SYNCHRO TAPPING CHUCK is designed with special technology that is micro movement

- * up and down: less than 0.01
- * right and left : less than 5 degree.

SELUX SYNCHRO TAPPING CHUCK improve the productivity and tool life.



TEST RESULT DATA

Model	COLLET CHUCK	SELUX SYNCHRO TAPPING CHUCK
TAP	M6X1.0 D12	
소재	ADC12-T6	
RPM	400	1200
가공수(HOLE)	3500	5500

※리지드탭 기능이 없는 장비는 사용시 탭이 파손될수 있습니다.

※스퍼너는 ER척과 공용으로 사용가능 합니다

SYNCHRO TAPPING CHUCK

D'ANDREA BORING SYSTEM



WHAT IS MHD?

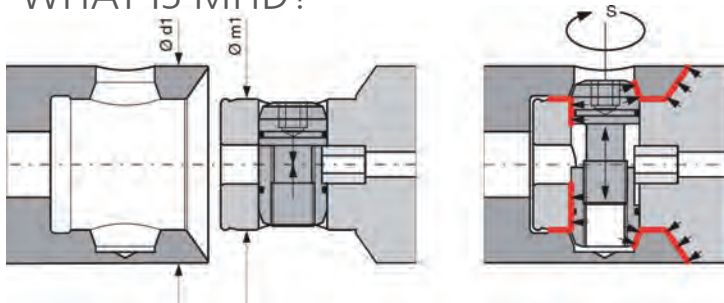

- Excellent Runout Accuracy
 연결부위 TAPER 방식으로 최적의 RUN-OUT 구현
 It is achieved extreme precision RUN-OUT by cylindrical-conical fit when extending
- Powerful clamping System
 강력한 체결력으로 다양한 길이조절에도 일체형같은 성능 발휘
 It is achieved utmost rigidity and concentricity with powerful clamping although.
 it is a various extension with many elements that is extension, reduction, adapter etc.
- Self centering System
 연결시 정확하게 중심을 잡아주는 방식으로 최적의 RUN-OUT 실현
 It is achieved extreme precision RUN-OUT by a radial expanding bolt for clamping and driving
- Various Boring Range
 최소 $\varnothing 2.5$~$\varnothing 2,800$까지 넓은 보링 범위
 A wide range of Boring system ($\varnothing 2.5$~$\varnothing 2,800$)



various BASIC HOLDER



BORING HEAD



KIT

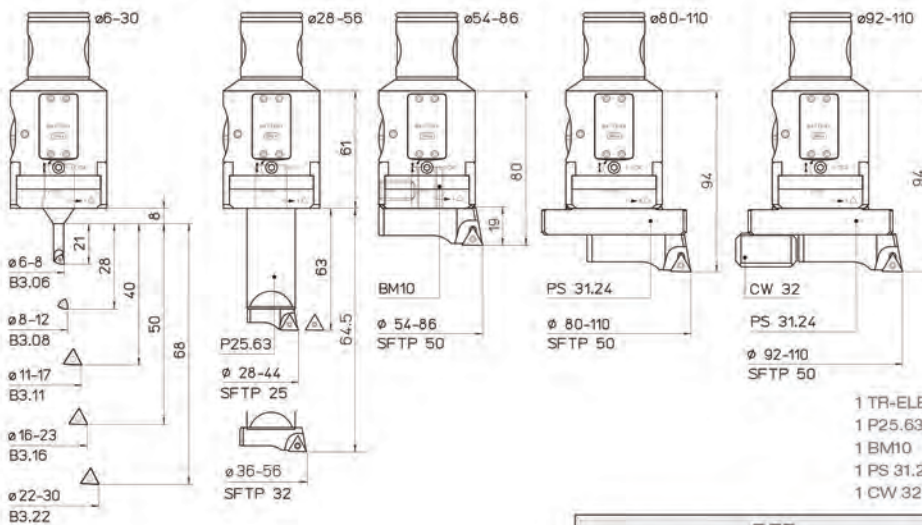

KIT K01 Ø 6 ~ 110



- 1 TR-ELETTRA 50 MHD'50
- 1 P25.63 1 B3.06 1 B3.22 5 TPGX 090202L DC100
- 1 BM10 1 B3.08 1 SFTP25 1 TPGX 110302L DC100
- 1 PS 31.24 1 B3.11 1 SFTP32 2 WCGT 020102L DC100
- 1 CW 32 1 B3.16 1 SFTP50

REF.	CODE	Ø
KIT K01 TR-ELETTRA 50 MHD'50	655200500500	6 ~ 110

KIT

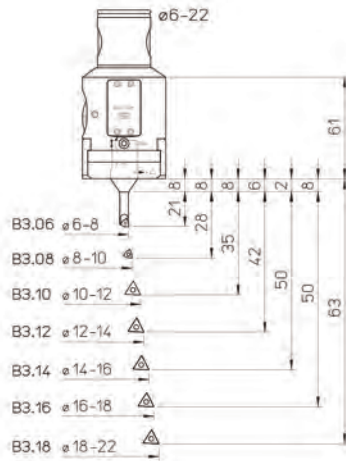

KIT K00 $\varnothing 6 \sim 22$



- 1 TR-ELETTRA 50 MHD'50
- 1 B3.06 1 B3.12 1 B3.18
- 1 B3.08 1 B3.14 5 TPGX 090202L DC100
- 1 B3.10 1 B3.16 2 WCGT 020102L DC100

REF.	CODE	\varnothing
KIT K00 TR-ELETTRA 50 MHD'50	655200500501	6 - 22

119



120



116



241



2 μ m



BPS
Large Bore boring
Rough/Super finishing



HSK and CAPTO TURNING SYSTEM

Excellent Precision
Excellent Quality

SELUX
NC TOOLING SYSTEM

GBT

CHUCK & Item

HYDRAULIC CHUCK
MILLING CHUCK
HIGH SPEED MILLING CHUCK
SHRINK FIT HOLDER
SSK COLLET CHUCK
HIGH SPEED GSK CHUCK
ER COLLET CHUCK
ENDMILL COLLET CHUCK
SYNCRO TAPPING CHUCK
TAPPING CHUCK HOLDER
NC DRILL CHUCK
SIDE LOCK HOLDER
MOLD SIDE LOCK HOLDER
MORSE TAPER HOLDER
FACE MILL ARBOR
PRO MILL ARBOR
PRO MILL ARBOR CUTTER
SIDE CUTTER ARBOR

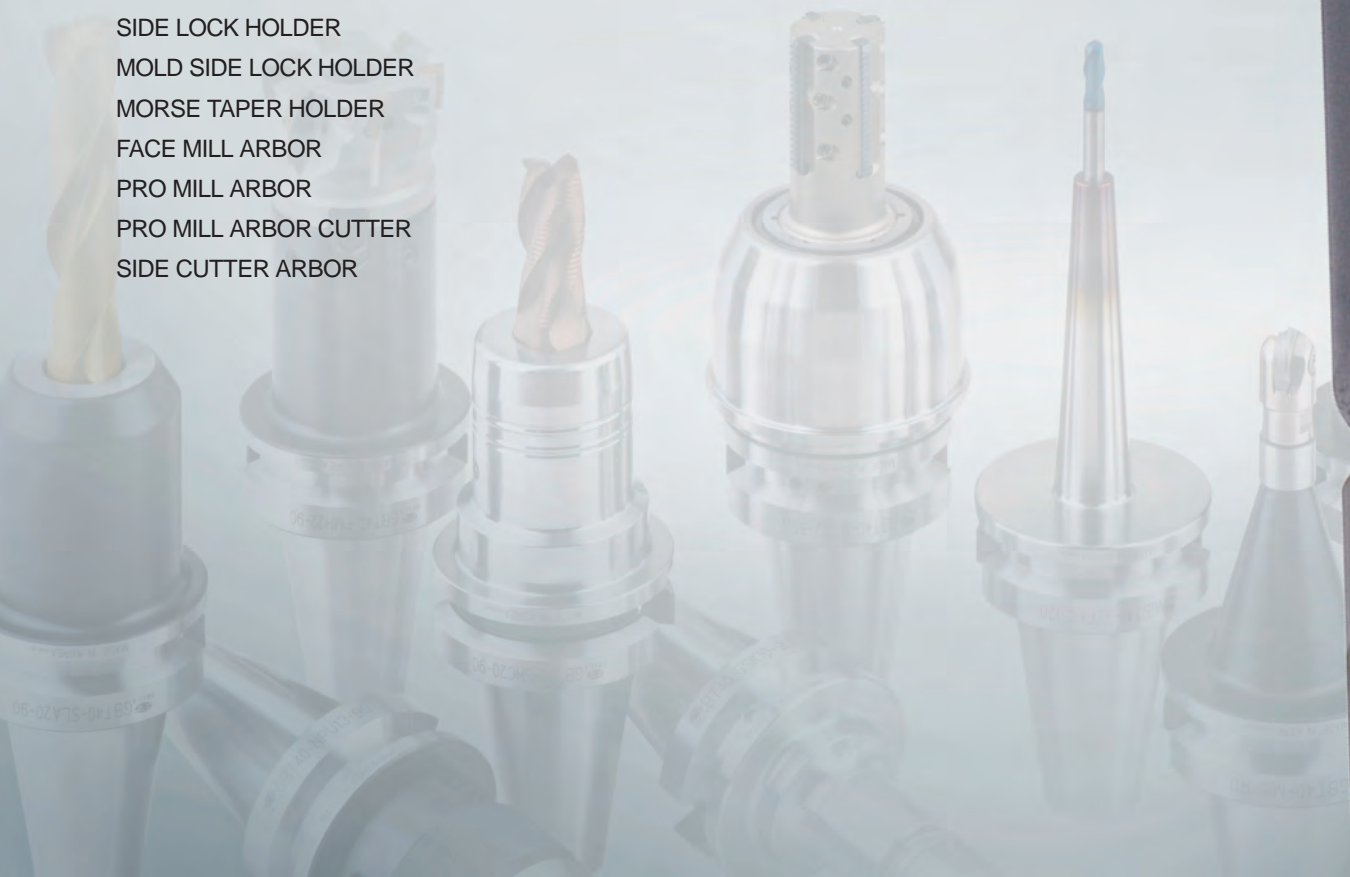

HYDRAULIC CHUCK

GBT SHANK HYDRAULIC CHUCK

Coolant-through hole
Clamping Range : $\varnothing 3.0 \sim \varnothing 32.0$



CODE No.

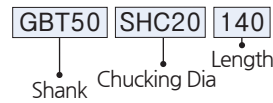

MAX
25,000
min⁻¹

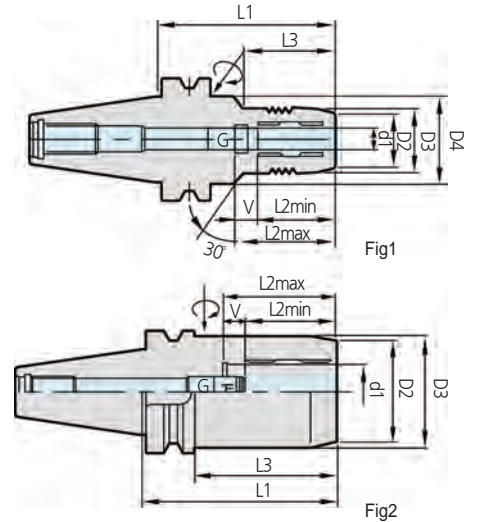

GBT Tooling System은 BT 2면구속 Spindle에서 2면구속으로 사용이 가능하며 일반 BT Spindle에서도 사용이 가능합니다.
GBT Tooling System can be used as the double face contact with the double face contact spindle and also used with BT standard spindle.

PRODUCT INFORMATION

- 4D 선단에서 3 μ m 이내의 흔들림정도
- 높은 정밀도와 고속가공에 최적화
- 유압방식의 강력한 파지력
- 렌치 하나로 쉽게 공구고정
- 3 μ m(T.I.R) Run-out at 4D away from shank nose.
- The optimal chck for excellent accuracy and high speed operation.
- Powerful clamping force of hydraulic type.
- Easy clamping with just one wrench.

CODE NO.	d1	D2	D3	D4	L1	L2min	L2max	V	L3	G	Fig	Weight (kg)
GBT30 - SHC 6 - 70	6	25	28	45	70	27.5	37.5	10	28	M5X0.8	Fig1	0.65
SHC 8 - 70	8	27	30									0.65
SHC 10 - 75	10	29	32		75	32.5	42.5		38	M6X1.0		0.75
SHC 12 - 75	12	31	34						44			0.8
SHC 16 - 90	16	35	38	-	90	42.5	52.5	-	M8X1.0	Fig2	0.9	
SHC 20 - 90	20	40	43								0.9	

- ▶ 유압척 사용시 절삭공구 Shank공차는 h6 안에 들어오는 절삭공구 사용을 권장합니다.
- ▶ 유압척 SHC12, SHC20, SHC32는 D또는 OD콜릿을 사용하여 다양하게 공구를 척킹 할 수 있습니다.
- ▶ 유압척 전용 콜릿은 P138~P139
- ▶ 황삭작업에는 권장하지 않습니다.
- ▶ Tolerance of cutting tool shank should be configured within h6.
- ▶ HYDRAURIC CHCUK SHC12, SHC20, SHC32 are possible to use various shank cutting tool with D or OD COLLET .
- ▶ HYDRAURIC COLLET are refered. P138~P139
- ▶ We do not recommended to use hydraulic chuck for roughing operation.

ID	Wrench
SHC 6~20 \varnothing	4mm
SHC 25~30 \varnothing	5mm

HYDRAULIC CHUCK

GBT SHANK HYDRAULIC CHUCK

Coolant-through hole
Clamping Range : $\varnothing 3.0 \sim \varnothing 32.0$



CODE No.

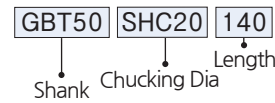

MAX
25,000
min⁻¹

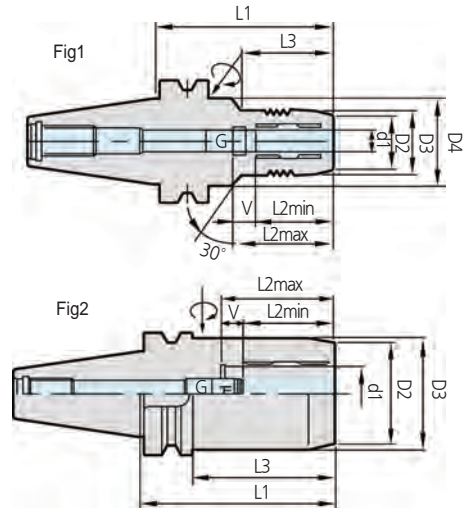

GBT Tooling System은 BT 2면구속 Spindle에서 2면구속으로 사용이 가능하며 일반 BT Spindle에서도 사용이 가능합니다.
GBT Tooling System can be used as the double face contact with the double face contact spindle and also used with BT standard spindle.

PRODUCT INFORMATION

- 4D 선단에서 3 μ m 이내의 흔들림정도
- 높은 정밀도와 고속가공에 최적화
- 유압방식의 강력한 파지력
- 렌치 하나로 쉽게 공구고정
- 3 μ m(T.I.R) Run-out at 4D away from shank nose.
- The optimal chck for excellent accuracy and high speed operation.
- Powerful clamping force of hydraulic type.
- Easy clamping with just one wrench.

CODE NO.	d1	D2	D3	D4	L1	L2min	L2max	V	L3	G	Fig	Weight (kg)					
GBT40 - SHC 6 - 90	6	25	28	50	90	27.5	37.5	10	44	M5X0.8	Fig1	1.3					
SHC 8 - 90	8	27	30						39	M6X1.0		1.3					
SHC10 - 90	10	29	32						44	M6X1.0		1.35					
SHC12 - 90	12	31	34						37.5	47.5		1.4					
SHC16 - 90	16	35	38						42.5	52.5		48	M8X1.0	1.5			
SHC20 - 90 - 140	20	40	43						140	2.0							
SHC25 - 100	25	53	57	-	100	51	61	73	M16X1.0	Fig2	1.7						
SHC32 - 105	32	58	63	-	105	55	65	-	M16X1.0	Fig2	2.1						
GBT50 - SHC 6 - 120	6	25	28	50	120	27.5	37.5	10	44	M5X0.8	Fig1	4.1					
SHC 8 - 120					8				27			30	120	40	4.1		
SHC10 - 120					10				29			32	120	44	4.1		
SHC12 - 120					12				31			34	120	32.5	42.5	44	M6X1.0
SHC16 - 120	16	35	38		120	37.5	47.5		44	M6X1.0		4.9					
SHC20 - 90	20	40	43		120	42.5	52.5		10	48		M8X1.0	Fig1	4.3			
SHC25 - 105					25					53				57	140	44	4.9
SHC32 - 115					32					58				63	140	48	5.0
SHC32 - 150					32					58				63	140	32	4.0
SHC20 - 120	20	40	43		90	42.5	52.5		10	32		M8X1.0	Fig1	4.4			
SHC25 - 150					25					53				57	120	48	4.4
SHC32 - 115					32					58				63	140	5.0	
SHC32 - 150				32	58			63		140	4.0						
SHC25 - 105	25	53	57	-	105	51	61	10	67	M16X1.0	Fig2	4.4					
SHC32 - 115				32	58				63			112	5.6				
SHC32 - 150				32	58				63			150	4.7				
SHC32 - 115	32	58	63	-	115	55	65	10	77	M16X1.0	Fig2	4.7					
SHC32 - 150				32	58				63			150	6.0				

MILLING CHUCK

Coolant-through hole
Clamping Range : $\phi 3.0 \sim \phi 42.0$



CODE No.

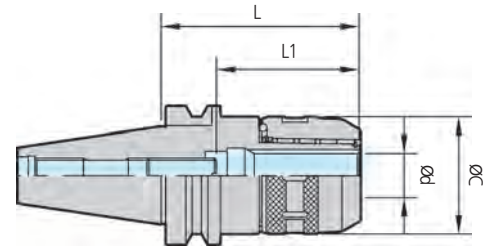
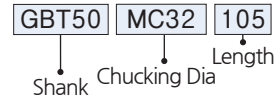

GBT Tooling System은 BT 2면구속 Spindle에서 2면구속으로 사용이 가능하며 일반 BT Spindle에서도 사용이 가능합니다.
GBT Tooling System can be used as the double face contact with the double face contact spindle and also used with BT standard spindle.

PRODUCT INFORMATION

- 높은 정밀도
- 간편한 척킹 시스템
- Taper 접촉 80% 이상 Taper공차 AT3로 보증
- 완전한 단면 밀착으로 강력 절삭
- 4배열 Roller System 방식으로 강력한 파지력
- Excellent Run-out Accuracy.
- Easy chucking system.
- More than 80% taper contact, we guarantee taper tolerance AT3.
- The strongest cutting power due to perfect face contact construction.
- Powerful clamping force by 4 needle roller system.

CODE NO.	ϕd	L	ϕC	L1	Collet	Weight (kg)
GBT30 - MC20 - 80	20	75	53	70	K20, NC20	1
MC32 - 100	32	100	72	78	K32, NC32	1.4
GBT40 - MC20 - 80	20	80	53	82	K20, NC20	1.5
- 90		90				1.6
MC32 - 85	32	85	72	90	K32, NC32	2
- 105		105				2.4
GBT50 - MC20 - 105	20	105	53	82	K20, NC20	4.4
- 135		135				4.8
MC32 - 105	32	105	74	125	K32, NC32	4.9
- 135		135				5.7
- 165		165				6.5
MC42 - 105	42	105	94	130	K42, NC42	5.5
- 135		135				6.9
- 165		165				8.3

Spare Parts		
Type	Option	
	Collet	Spanner
MC20	K20-NC20	MC20-SP(50-55)
MC25	K25-NC25	MC25-SP(56-61)
MC32	K32-NC32	MC32-SP(68-75)
MC42	K42-NC42	MC42-SP(88-96)

- ▶ 고속 바란스 작업시 추가 비용이 청구됩니다.
- ▶ 밀링척은 콜릿을 사용하여 다양한 Shank의 공구들을 체결할 수 있습니다.
- ▶ 밀링척 전용 콜릿은 P140~P143
- ▶ 밀링척 스페너는 별도 판매품 입니다. P157
- ▶ Extra charge for high speed balance.
- ▶ MILLING CHUCK is possible to use cutting tools of a various shank with COLLET.
- ▶ K-COLLET are referred. P140~P143
- ▶ Spanner is ordered separately. P157

HIGH SPEED MILLING CHUCK

Coolant-through hole
Clamping Range : $\phi 3.0 \sim \phi 32.0$



CODE No.

GBT40	MC32	85	G
Shank	Chucking Dia	Length	High Speed



MAX
25,000
min⁻¹

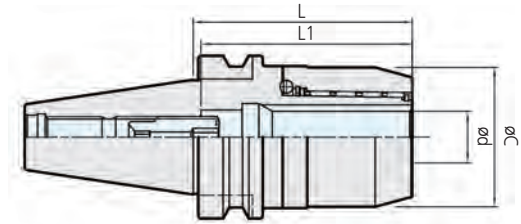

GBT Tooling System은 BT 2면구속 Spindle에서 2면구속으로 사용이 가능하며 일반 BT Spindle에서도 사용이 가능합니다.
 GBT Tooling System can be used as the double face contact with the double face contact spindle and also used with BT standard spindle.

PRODUCT INFORMATION

- 고속 가공에서 높은 정도
- 강력한 파지력
- 스패너는 GH 스패너 사용(별매)
- G6.3 max 25,000RPM
- 원형너트로 고속 절삭시 소음 감소
- Excellent Run-out Accuracy.
- Powerful clamping force.
- GH spanner is orderd separately.
- G6.3 max 25,000 RPM.
- The operation noise is reduced by assembled circle style nut.

CODE NO.	ød	L	øC	L1	Collet	MAX rpm	Weight (kg)
GBT30 - MC20 - 80G	20	80	48	70	K20, NC20	25,000	0.6
MC25 - 80G	25	80	55		K25, NC25		0.9
GBT40 - MC20 - 80G	20	80	48	82	K20, NC20	25,000	1.3
- 90G		90					1.4
MC25 - 80G	25	80	55	85	K25, NC25	20,000	1.5
- 90G		90					1.6
MC32 - 85G	32	85	68	80	K32, NC32	20,000	1.6
- 105G		105					90
GBT50 - MC20 - 105G	20	105	48	105	K20, NC20	20,000	4.1
- 135G		135					4.4
MC25 - 105G	25	105	55	90	K25, NC25	15,000	4.4
- 135G		135					4.8
MC32 - 105G	32	105	68	110	K32, NC32	15,000	4.7
- 135G		135					5.2

Spare Parts		
Type	Option	
	Collet	Spanner
MC20-G	K20-NC20	MC20-GH
MC25-G	K25-NC25	MC25-GH
MC32-G	K32-NC32	MC32-GH

- ▶ 고속형밀링척은 콜릿을 사용하여 다양한 Shank의 공구들을 체결할 수 있습니다.
- ▶ 밀링척 전용 콜릿은 P140 ~ P143
- ▶ 고속형밀링척 GH스패너는 별도 판매품 입니다. P157

- ▶ High speed MILLING CHUCK is possible to use cutting tools of a various shank with COLLET.
- ▶ K-CHUCK COLLET is refered. P140~P143
- ▶ GH SPANNER for high speed milling chuck is orderd separately. P157

SHRINK FIT HOLDER

Coolant-through hole
Clamping Range : $\phi 3.0 \sim \phi 12.0$

CODE No.

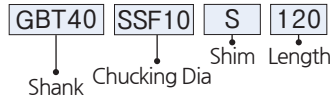

MAX
25,000
min⁻¹

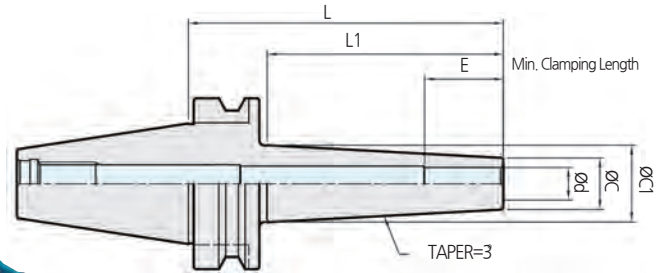

GBT Tooling System은 BT 2면구속 Spindle에서 2면구속으로 사용이 가능하며 일반 BT Spindle에서도 사용이 가능합니다.
GBT Tooling System can be used as the double face contact with the double face contact spindle and also used with BT standard spindle.

PRODUCT INFORMATION

- 4D선단에서 3 μ m이내의 흔들림 정도
- 높은 정밀도와 강력한 파지력
- 대칭적, 슬림한 디자인으로 가공최적화
- 전제품 내부급유 (Coolant Through Hole)
- 3 μ m(T.I.R) Run-out at 4D away from shank nose.
- Excellent Run-out accuracy and powerful clamping.
- Optimal operation with slim and symmetrical design.
- All products can be used for center through coolant type.

Code No.	ϕd	ϕC	$\phi C1$	L	L1	E	Weight (kg)
GBT30 - SSF 4S - 80	4	7	13	80	42	12	0.4
SSF 6S - 80	6	11	17		55		
- 120			21	120	95	18	0.45
SSF 8S - 80	8	13	19	80	55	24	0.4
- 120			23	120	95		0.45
SSF10S - 80	10	16	22	80	55	30	0.4
- 120			26	120	95		0.45
SSF12S - 80	12	19	25	80	55		0.5
- 120			29	120	95		0.55
GBT40 - SSF 3S - 90	3	6	26	90	37	9	1.0
SSF 4S - 90	4	7				12	1.0
SSF 6S - 120	6	11	20	120	90	18	1.1
- 160			25	160	130		1.2
SSF 8S - 120	8	13	22	120	90	24	1.1
- 160			27	160	130		1.3
SSF10S - 120	10	16	25	120	90	30	1.1
- 160			30	160	130		1.4
SSF12S - 120	12	19	28	120	90		1.2
- 160			33	160	130		1.4
GBT50 - SSF 6S - 120	6	11	19	120	79	18	3.8
- 160			23	160	119		4.1
SSF 8S - 120	8	13	21	120	79	24	3.8
- 160			25	160	119		4.1
SSF10S - 120	10	16	24	120	79	30	3.9
- 160			28	160	119		4.2
SSF12S - 120	12	19	27	120	79		3.9
- 160			31	160	119		4.3

- ▶ 열박음홀더 사용시 절삭공구 Shank경은 h6의 제품을 사용해 주십시오.
- ▶ 절삭공구는 초경 Shank만 대응합니다. (하이스 제품 사용금지)

- ▶ 열박음홀더 사용시 지정된 고주파 히팅기를 사용해서 절삭공구 체결을 권장합니다.
- ▶ SELUX 고주파 히팅기는 P153
- ▶ 절삭공구 최소 삽입길이를 준수해 주시기 바랍니다.
- ▶ 공구길이조정 Stopper는 별도 판매 입니다. P153
- ▶ 열박음홀더 사용시 오일홀 풀스터드 볼트를 권장합니다.

- ▶ Please use only carbide cutting tools of a shank tolerance within H6.
- ▶ Please use only carbide cutting tools for shink fit holder. (Prohibit use HSS CUTTING TOOLS)
- ▶ We recommend shrink fit equipment when you use shink fit holder.
- ▶ SELUX shrink fit equipment is refered. P153
- ▶ Please follow minimum insertion lengh of the cutting tools.
- ▶ Stopper for adjusting cutting tool lengh order separately. P153
- ▶ We recommend oil hole Pull stud bolt for shrink fit holder.

SHRINK FIT HOLDER

Coolant-through hole

Clamping Range : $\phi 3.0 \sim \phi 20.0$

CODE No.

GBT40 SSF10 160
Shank Chucking Dia Length



MAX
25,000
min⁻¹

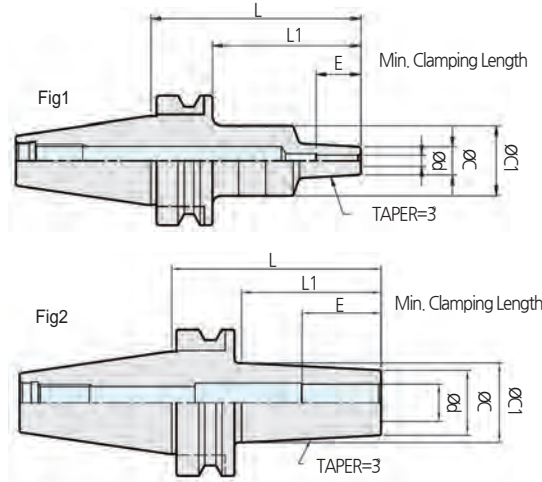

GBT SHANK SHRINK FIT HOLDER

GBT Tooling System은 BT 2면구속 Spindle에서 2면구속으로 사용이 가능하며 일반 BT Spindle에서도 사용이 가능합니다.
GBT Tooling System can be used as the double face contact with the double face contact spindle and also used with BT standard spindle.

PRODUCT INFORMATION

- 4D선단에서 3 μ m이내의 흔들림 정도
- 높은 정밀도와 강력한 파지력
- 대칭적, 슬림한 디자인으로 가공최적화
- 전제품 내부급유 (Coolant Through Hole)
- 3 μ m(T.I.R) Run-out at 4D away from shank nose.
- Excellent Run-out accuracy and powerful clamping.
- Optimal operation with slim and symmetrical design.
- All products can be used for center through coolant type.

Code No.	ϕd	ϕC	$\phi C1$	L	L1	E	Fig	Weight (kg)
GBT30 - SSF 3 - 75	3	7.5	25	75	53	12	1	0.5
SSF 4 - 75	4	10				16		
SSF 6 - 75	6	12				24		
SSF 8 - 75	8	14				26		
SSF10 - 75	10	16				26		
SSF12 - 75	12	20				30		
SSF16 - 75	16	26				34		
GBT40 - SSF 3 - 90	3	7.5	26	90	37	9	1	1.0
SSF 4 - 90	4	10				12		1.0
SSF 6 - 90	6	14	20	160	130	18	2	1.2
- 160			21					1.4
SSF 8 - 90	8	18	24	160	130	24	2	1.2
- 160			32					1.4
SSF10 - 90	10	22	28	160	130	30	2	1.3
- 160			36					1.5
SSF12 - 90	12	24	30	160	130	34	2	1.3
- 160			38					1.6
SSF16 - 90	16	28	34	160	130	40	2	1.3
- 160			42					1.8
SSF20 - 90	20	34	40	160	130	40	2	1.3
- 160			48					2.1
GBT50 - SSF 6 - 100	6	14	20	100	119	18	2	3.7
- 160			26					3.9
SSF 8 - 100	8	18	24	100	119	24	2	3.7
- 160			30					3.9
SSF10 - 100	10	22	28	100	119	30	2	3.8
- 160			34					4.1
SSF12 - 100	12	24	30	100	119	34	2	3.8
- 160			36					4.1
SSF16 - 100	16	28	34	100	119	40	2	3.8
- 160			40					4.1
SSF20 - 100	20	34	46	100	119	40	2	3.9
- 160			53					4.4

▶ 열박음척 사용시 척 내경에 있는 방청유를 제거후에 사용하셔야 합니다. 내구성 저하 원인이 됩니다.

▶ Please clean the shank outside and inside of shrink fit before use. If you don't clean the shrink fit, it has problem about Run-out and toollife.

SSK COLLET CHUCK



GBT SHANK
SSK COLLET CHUCK



Coolant-through hole
Clamping Range : $\varnothing 1.0 \sim \varnothing 25.4$

CODE No.

GBT50 | SSK10 | 135
Shank | Chucking Dia | Length

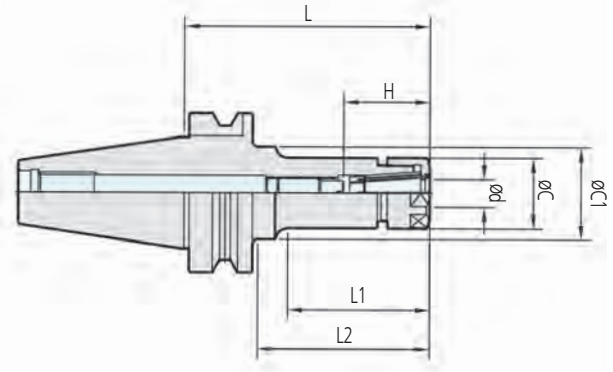

GBT Tooling System은 BT 2면구속 Spindle에서 2면구속으로 사용이 가능하며 일반 BT Spindle에서도 사용이 가능합니다.
GBT Tooling System can be used as the double face contact with the double face contact spindle and also used with BT standard spindle.

PRODUCT INFORMATION

- 8Taper 의 강력한 파지력
- 높은 정밀도와 빠른 가공에 적합
- 드릴, 센터드릴, 엔드밀, 탭, 리머용으로 사용
- Powerful clamping force of 8Taper.
- Excellent Run-out Accuracy.
- SSK COLLET CHUCK is suitable for a various operation using drill, endmill, tap and reamer.

Code No.	ød	øC	øC1	H		L	L1	L2	Collet	Weight (kg)		
				Min	Max							
GBT30 - SSK 6 - 60	0.9~6.0	19.5	19.5	21	35	60	33	33	SC6	0.7		
			32			90	56	65		0.7		
SSK10 - 60	1.75~10.0	27.5	27.5	30	50	60	35	35	SC10	0.9		
						90	65	65		1.0		
						120	95	95		1.1		
SSK13 - 60	2.75~13.0	33	33	31	50	60	35	35	SC13	1.0		
						90	65	65		1.1		
SSK16 - 60	2.75~16.0	40	40	45	60	60	37	37	SC16	1.1		
						90	67	67		1.2		
GBT40 - SSK 6 - 60	0.9~6.0	19.5	19.5	21	35	60	30	30	SC6	1.0		
			32			90	51	60		1.1		
						120	60	90		1.4		
SSK10 - 60	1.75~10.0	27.5	27.5	30	50	60	32	32	SC10	1.1		
			40			90	48	60		1.2		
						120	73	90		1.4		
			34.5			150	118	118		1.6		
SSK13 - 60	2.75~13.0	33	33	31	65	60	28	28	SC13	1.2		
						90	58	58		1.4		
						120	88	88		1.6		
SSK16 - 60	2.75~16.0	40	40	50	65	60	32	32	SC16	1.3		
						40	67	90		58	58	1.5
						40	70	120		88	88	1.7
								150		118	118	1.9
SSK20 - 60	3.6~20.0	48	48	47	60	60	32	32	SC20	1.3		
						90	60	60		1.6		
						47	80	120		90	90	2.0
SSK25 - 75	15.6~25.4	55	55	40	60	75	46	46	SC25	1.5		
						55	75	90		61	61	1.8
						55	85	120		91	91	2.0

SSK COLLET CHUCK



Code No.	ød	øC	øC1	H		L	L1	L2	Collet	Weight (kg)
				Min	Max					
GBT50 - SSK 6 - 105	0.9~6.0	19.5	32	21	35	105	55	64	SC 6	3.8
- 135						135	60	92		4.0
- 165						165	60	114		4.2
SSK10 - 105	1.75~10.0	27.5	27.5	30	50	105	57	57	SC10	4.2
- 135			32			70	92	4.4		
- 165			36			75	114	4.6		
SSK13 - 105	2.75~13.0	33	33	31	65	105	62	62	SC13	4.5
- 135			45			92	122	4.7		
- 165			45			92	122	4.9		
SSK16 - 105	2.75~16.0	40	40	40	70	105	62	62	SC16	4.7
- 135			50			92	92	4.9		
- 165			50			90	122	5.1		
SSK20 - 105	3.6~20.0	48	48	47	80	105	62	62	SC20	4.3
- 135			135			92	92	4.6		
- 165			165			122	122	5.0		
SSK25 - 105	15.6~25.4	55	55	50	85	105	62	62	SC25	5.2
- 135			135			92	92	5.4		
- 165			165			122	122	5.6		

Spare Parts				
Type	Basic		Option	
	Nut	Adjust Screw	Spanner	Collet
SSK 6	SCN- 6 (HEXA)	BTD0825-C	SC 6-SP	SC 6-ø
SSK10	SCN-10 (HEXA)	BTD1225-C	SC10-SP	SC10-ø
SSK13	SCN-13	BTD1525-C	SC13-SP	SC13-ø
SSK16	SCN-16	BTD1830-C	SC16-SP	SC16-ø
SSK20	SCN-20	BTD2230-C	SC20-SP	SC20-ø
SSK25	SCN-25	BTD2838-C	SC25-SP	SC25-ø

- ▶ 너트, 조절나사 및 콜렛추출도구는 부속되어 있습니다.
- ▶ 스페너는 별매입니다. **P157**
- ▶ Synchronized Tap 사용시 SSK10을 사용하십시오.
Aluminum MAX Tapping M12
Steel MAX Tapping M10
Stainless Steel MAX Tapping M8
위 사양 이상인경우는 Milling Chuck에 K-Collet을 사용하시길 바랍니다.
- ▶ SSK적 콜렛은 **P144~P145**
- ▶ 절삭공구 체결시 무리한 힘이 가해질시 너트 및 홀더가 파손 될 수 있습니다.
- ▶ 고속 바란스 작업시 추가 비용이 청구됩니다.
- ▶ NUT, ADJUST SCREW, COLLET REMOVER are included.
- ▶ Spanner is ordered separately. **P157**
- ▶ Please use SSK10 when you use Synchronized Tap.
Aluminum MAX Tapping M12
Steel MAX Tapping M10
Stainless Steel MAX Tapping M8
If it has problem, We recommend K COLLET with Milling Chuck.
- ▶ SC COLLET is referred. **P144 ~ P145**
- ▶ The nut or shank of chuck can be destroyed if you too strongly clamp nut and holder.
- ▶ Extra charge for high speed balance.

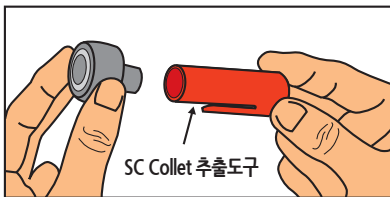

SSK NUT에 SC COLLET 체결시에는 전용 콜렛 추출도구를 사용하시기 바랍니다.

Please use private remover when you insert the SSK COLLET in SSK NUT

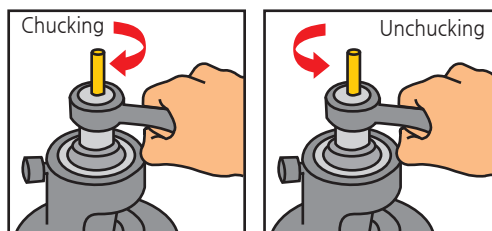

SSK 척은 공구체결시 40 Torque 이상의 힘이해질시 너트 및 바디가 파손 될 수 있습니다. ※주의 (SSK6, SSK10)

SSK NUT and SSK CHCUK is possible to be broken if you clamp chuck and nut over 40 Torque ※ **WARNING** (SSK6, SSK10)

HIGH SPEED GSK CHUCK(P CLASS)

Coolant-through hole
Clamping Range : $\phi 1.0 \sim \phi 25.4$

CODE No.

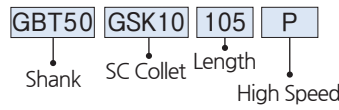

MAX
40,000
min⁻¹

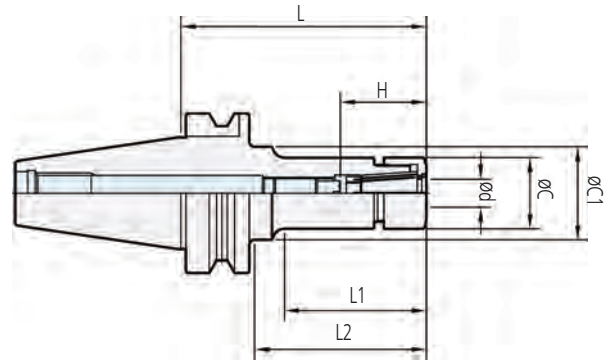

GBT Tooling System은 BT 2면구속 Spindle에서 2면구속으로 사용이 가능하며 일반 BT Spindle에서도 사용이 가능합니다.
GBT Tooling System can be used as the double face contact with the double face contact spindle and also used with BT standard spindle.

PRODUCT INFORMATION

- 고속가공에서 높은 정도
- 8Taper의 강력한 파지력
- 원형 너트로 컴팩트한 디자인
- 스패너는 PH스패너 사용(별매)
- G2.5X max 40,000 RPM
- 고속형GSK척에는 P CLASS 콜릿 사용을 권장
- Excellent Run-out Accuracy.
- Powerful clamping force of 8taper.
- Circle style nut designed compactly
- PH spanner is ordered separately.
- G2.5X max 40,000 RPM.
- We recommend to use P CLASS SC COLLET when you use GSK CHCUK.

Code No.	ød	øC	øC1	H		L	L1	L2	Collet	MAX rpm	Weight (kg)		
				Min	Max								
GBT30 - GSK 6- 60P - 90P	0.9~6.0	19.5	19.5	21	35	60	33	33	SC6P	40,000	0.7		
			32			90	56	65			0.7		
GSK10- 60P - 90P -120P	1.75~10.0	27.5	27.5	30	50	60	35	35	SC10P	40,000	0.9		
						90	65	65			1.0		
						120	95	95			1.1		
GSK13- 60P - 90P	2.75~13.0	33	33	31	65	60	35	35	SC13P	40,000	1.0		
						90	65	65			1.1		
						120	95	95			1.1		
GSK16- 60P - 90P	2.75~16.0	40	40	45	65	60	37	37	SC16P	30,000	1.1		
						90	67	67			1.2		
						120	95	95			1.2		
GBT40 - GSK 6- 60P - 90P -120P	0.9~6.0	19.5	19.5	21	35	60	30	30	SC6P	25,000	1.0		
			32			90	51	60			1.1		
			120			60	90	1.4					
GSK10- 60P - 90P -120P -150P	1.75~10.0	27.5	27.5	30	50	60	32	32	SC10P	25,000	1.1		
			40			90	48	60			1.2		
			120			73	90	1.4					
			150			150	118	118			1.6		
			34.5			150	118	118			1.6		
GSK13- 60P - 90P -120P	2.75~13.0	33	33	31	65	60	28	28	SC13P	25,000	1.2		
						90	58	58			1.4		
						120	88	88			1.6		
GSK16- 60P - 90P -120P -150P	2.75~16.0	40	40	50	65	60	32	32	SC16P	25,000	1.3		
						40	67	90			58	58	1.5
						40	70	120			88	88	1.7
						40	70	150			118	118	1.9
GSK20- 60P - 90P -120P	3.6~20.0	48	48	47	80	60	32	32	SC20P	20,000	1.3		
						90	60	60			1.6		
						120	90	90			2.0		
GSK25- 75P - 90P -120P	15.6~25.4	55	55	40	75	60	46	46	SC25P	20,000	1.5		
						55	75	90			61	61	1.8
						55	85	120			91	91	2.0

HIGH SPEED GSK CHUCK(P CLASS)

Coolant-through hole
Clamping Range : $\phi 1.0 \sim \phi 25.4$



CODE No.
GBT50 **GSK10** **105** **P**
 Shank SC Collet Length High Speed



MAX
40,000
min⁻¹

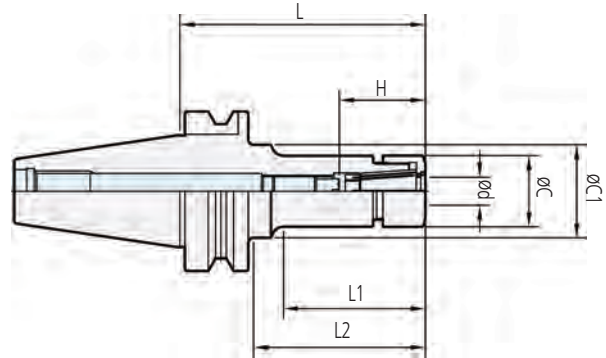

Code No.	ød	øC	øC1	H		L	L1	L2	Collet	MAX rpm	Weight (kg)
				Min	Max						
GBT50 - GSK 6 - 105P	0.9~6.0	19.5	32	21	35	105	55	64	SC6P	20,000	3.8
- 135P						135	60	92			4.0
- 165P						165	60	114			4.2
GSK10 - 105P	1.75~10.0	27.5	27.5	30	50	105	57	57	SC10P	20,000	4.2
- 135P			32			70	92	4.4			
- 165P			36			75	114	4.6			
GSK13 - 105P	2.75~13.0	33	33	31	65	105	62	62	SC13P	20,000	4.5
- 135P			33			92	92	4.7			
- 165P			45			92	122	4.9			
GSK16 - 105P	2.75~16.0	40	40	40	70	105	62	62	SC16P	20,000	4.7
- 135P			40			92	92	4.9			
- 165P			50			90	122	5.1			
GSK20 - 105P	3.6~20.0	48	48	47	80	105	62	62	SC20P	15,000	4.3
- 135P			135			92	92	4.6			
- 165P			165			122	122	5.0			
GSK25 - 105P	15.6~25.4	55	55	50	85	105	62	62	SC25P	15,000	5.2
- 135P			135			92	92	5.4			
- 165P			165			122	122	5.6			

Spare Parts				
Type	Basic		Option	
	Nut	Adjust Screw	Spanner	Collet
GSK 6P				
GSK10P	SCN- 6P	BTD0825-C	SC 6-PH	SC 6-øP
GSK13P	SCN-10P	BTD1225-C	SC10-PH	SC10-øP
GSK16P	SCN-13P	BTD1525-C	SC13-PH	SC13-øP
GSK20P	SCN-16P	BTD1830-C	SC16-PH	SC16-øP
GSK25P	SCN-20P	BTD2230-C	SC20-PH	SC20-øP
	SCN-25P	BTD2838-C	SC25-PH	SC25-øP

- ▶ 너트, 조절나사 및 콜릿추출도구는 부속되어 있습니다. ▶ NUT, ADJUST SCREW, COLLET REMOVER are included.
- ▶ 스패너는 별매입니다. P157 ▶ Spanner is ordered separately. P157
- ▶ GSK척 콜릿은 P144~P145 ▶ P CLASS SC COLLET for GSK CHUCK is referred. P144 ~ P145
- ▶ 절삭공구 체결시 무리한 힘이 가해질시 너트및 홀더가 파손 될 수 있습니다. ▶ It can be destoried nut or shank of chuck if you too strongly clamp nut and holder.

ER COLLET CHUCK

GBT SHANK
ER COLLET CHUCK



Coolant-through hole
Clamping Range : $\varnothing 0.5 \sim \varnothing 20.0$

CODE No.

GBT50 ER16 105
Shank ER Collet Size Length

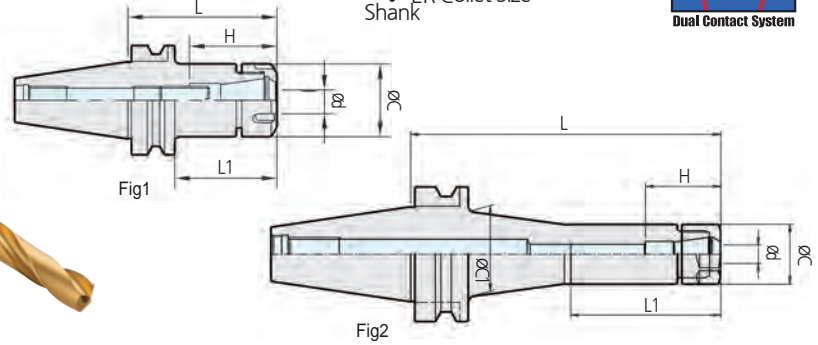

GBT Tooling System은 BT 2면구속 Spindle에서 2면구속으로 사용이 가능하며 일반 BT Spindle에서도 사용이 가능합니다.
GBT Tooling System can be used as the double face contact with the double face contact spindle and also used with BT standard spindle.

PRODUCT INFORMATION

- 안정적인 정밀도와 파지력
- Reliable accuracy and Powerful clamping force.
- 쉽고빠른 공구교환
- Easy and quick tool exchange.
- 드릴, 엔드밀, 탭 다양한 사용범위
- ER COLLET CHUCK is suitable for a various operation using drill, endmill, tap.

Code No.	ød	øC	C1	H		L	L1	Collet	Fig	Weight (kg)
				Min	Max					
GBT30 - ER11 - 60	0.5~7.0	19		19	34	60	35	ER11	1	0.5
- 90						90	65			0.6
ER16 - 60	0.5~10.0	28		23	43	60	35	ER16	1	0.5
- 90						90	65			0.6
ER20 - 60	1.0~13.0	35	-	25	48	60	35	ER20	1	0.5
- 90						90	65			0.7
ER25 - 60	1.0~16.0	42		34	54	60	35	ER25	1	0.6
- 90						90	65			0.8
ER32 - 60	2.0~20.0	50		40	60	60	35	ER32	1	0.5
- 90						90	65			0.9
GBT40 - ER11 - 60	0.5~7.0	19	-	19	34	60	28	ER11	1	1.0
- 90			26			90	58		2	1.1
- 120			120			65	1.2			
ER16 - 60	0.5~10.0	28	-	23	43	60	28	ER16	1	1.1
- 90			90			58	1		1.2	
- 120			36			120	73		2	1.3
ER20 - 60	1.0~13.0	35	-	25	48	60	30	ER20	1	1.1
- 90			90			60	1.3			
- 120			120			90	1.5			
ER25 - 60	1.0~16.0	42	-	34	54	60	30	ER25	1	1.2
- 90			90			60	1.4			
- 120			120			90	1.6			
ER32 - 60	2.0~20.0	50	-	40	60	60	30	ER32	1	1.3
- 90			90			60	1.4			
- 120			120			90	1.7			
GBT50 - ER11 - 105	0.5~7.0	19	-	19	34	105	62	ER11	1	3.7
- 135			32			135	61		2	3.8
- 165			35			165	61		4.0	
ER16 - 105	0.5~10.0	28	-	23	43	105	62	ER16	1	4.0
- 135			32			135	70		2	4.1
- 165			36			165	77		4.2	
ER20 - 105	1.0~13.0	35	-	25	48	105	62	ER20	1	3.9
- 135			40			135	92		2	4.1
- 165			165			87	4.5			
ER25 - 105	1.0~16.0	42	-	34	54	105	62	ER25	1	4.1
- 135			50			135	92		2	4.3
- 165			165			90	4.4			
ER32 - 105	2.0~20.0	50	-	40	60	105	62	ER32	1	4.3
- 135			135			92	4.9			
- 165			165			122	5.0			

- ▶ 내부급유 사용시에는 방수형콜릿이나 방수형 너트를 사용 해주십시오.
- ▶ ER콜릿은 P146
- ▶ 스페너는 별매했습니다. P157
- ▶ 고속 바란스 작업시 추가 비용이 청구됩니다.
- ▶ ER척 스페어 파트는 P56
- ▶ Please use waterproof collet and waterproof nut for operating centre through coolant type.
- ▶ ER COLLET is refered. P146
- ▶ Spanner is ordered separately. P157
- ▶ Extra charge for high speed balance.
- ▶ The spare parts for ER CHCUK are refered. P56

ENDMILL COLLET CHUCK



GBT SHANK
ENDMILL COLLET CHUCK

Coolant-through hole
Clamping Range : $\phi 6.0 \sim \phi 20.0$



CODE No.

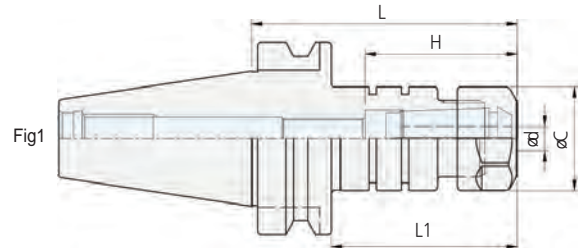
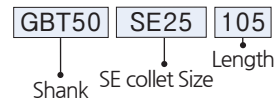

PRODUCT INFORMATION

- SE척 전용 콜릿 사용
- ENDMILL 전용 COLLET CHUCK
- 4도 TAPER의 강력한 파지력
- 5 μ m at 4D (T.I.R) (Max G2.5 at 20,000 rpm)
- Please use dedicated collet for SE COLLET CHUCK
- SE COLLET CHUCK for dedicated ENDMILL
- Strong Clamping Power of 4 degree TAPER
- 5 μ m at 4D (T.I.R) (Max G2.5 at 20,000 rpm)

CODE NO.	ϕd	ϕC	H	L	L1	Collet	Weight (kg)	Fig
GBT40 - SE20 - 90	6,8,10,12	34	40.5	90	63	SE20	1	1
SE25 - 90	6,8,10,12,16	42	48			SE25	1.4	
SE32 - 90	6,8,10,12,16,20	50	58			SE32	1.5	
GBT50 - SE20 - 105	6,8,10,12	34	40.5	105	67	SE20	1.6	
- 135				135	97		2	
- 165				165	127		2.4	
SE25 - 105	6,8,10,12,16	42	48	105	67	SE25	4.4	
- 135				135	97		4.8	
- 165				165	127		4.9	
SE32 - 105	6,8,10,12,16,20	50	58	105	67	SE32	5.7	
- 135				135	97		6.5	
- 165				165	127		5.5	

Spare Parts				
Type	Option			
	NUT	Adjust Screw	Spanner	SE Collet
SE20				
SE25	UM/SE20(HEXA)	BTD1325-C	SE20-SP	SE20- ϕ
SE32	UX/SE25	BTD1830-C	SE25-SP	SE25- ϕ
	UX/SE32	BTD2230-C	SE32-SP	SE32- ϕ

- ▶ SE NUT와 ER NUT은 호환성이 있으나 SE너트로 별도 구매 바랍니다. (ER NUT를 SE CHUCK에 사용을 금지합니다.)
- ▶ 스패너는 별도 구매입니다.
- ▶ SE콜릿은 P146
- ▶ Nut has compatible with SE NUT and ER NUT. But Please order separately when you need NUT. (Prohibit that SE CHUCK use ER NUT)
- ▶ Spanner is ordered separately
- ▶ SE COLLET is referred. P146

SYNCHRO TAPPING CHUCK

GBT SHANK SYNCHRO TAPPING CHUCK

Coolant-through hole
Clamping Range : M2.0 ~ M22.0



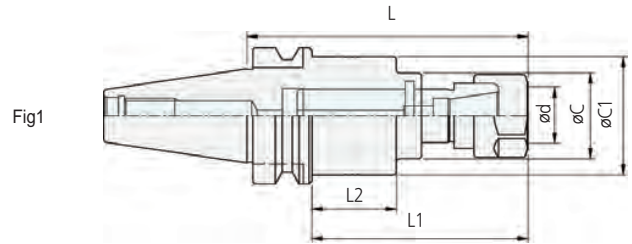
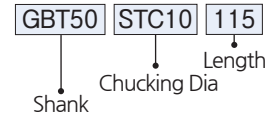

CODE No.



PRODUCT INFORMATION

- 고속 가공용 TAPPING CHUCK (Max. G6.3 at 10,000 rpm)
- 4D x 25 μ m(T.I.R)
- 특수 설계로 인한 TAP 파손 방지
- ER TAP COLLET 사용 권장 (STC3 은 일반 ER11 COLLET)
- TAPPING CHUCK for high speed. (Max. G6.3 at 10,000 rpm)
- 4D x 25 μ m(T.I.R)
- Special designed Tapping chuck for Tapping
- recommend ER TAP COLLET When you use Synchro tapping chuck (STC3 use ER11 collet)

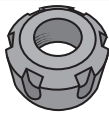
CODE NO.	ϕ d	ϕ C	ϕ C1	L	L1	L2	Collet	Weight (kg)	Fig
GBT30 - STC 3 - 80	M1~M3	36	25	80	58	22.5	ER11	0.6	1
STC 10 - 95	M2~M10	40	29	95	73	28.5	TER16	0.9	
GBT40 - STC 10 - 100	M2~M10	40	29	100	73	28.5	TER16	1.3	
STC 22 - 115	M4~M22	54	42	115	88	28	TER32	1.4	
GBT50 - STC 10 - 115	M2~M10	40	29	115	77	32.5	TER16	1.5	
STC 22 - 120	M4~M22	65	48	120	82	21	TER32	1.6	

Spare Parts			
Type	NUT	Option	
		Spanner	TER Collet
STC 3			
STC 10	UM/ER11(HEXA)	ER11-SP	ER11- ϕ
STC 10	UM/ER16(HEXA)	ER16-SP	TER16- ϕ
STC 22	UX/ER32	ER32-SP	TER32- ϕ

- ▶ 스페너는 별매입니다.
- ▶ 동기화 기능(리지드)이 있는 장비에서 사용 가능합니다.
- ▶ ER콜릿은 P146
- ▶ TER콜릿은 P148

- ▶ Spanner is ordered separately.
- ▶ The machining Center has Synchro function (RIGID TAP) to use STC CHUCK
- ▶ ER COLLET is referred. P146
- ▶ TER COLLET is referred. P148

TAPPING CHUCK HOLDER

Tapping Range : M3 ~ M36



CODE No.

GBT50 TCH12 125
 Shank MAX Tapping Length

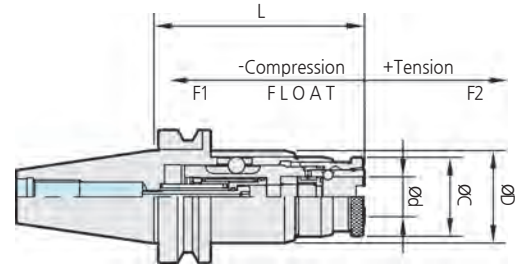

GBT Tooling System은 BT 2면구속 Spindle에서 2면구속으로 사용이 가능하며 일반 BT Spindle에서도 사용이 가능합니다.
 GBT Tooling System can be used as the double face contact with the double face contact spindle and also used with BT standard spindle.

PRODUCT INFORMATION

- 플로팅 타입으로 인장수축 장치 내장
- 공구교환이 빠르고 편리함
- 관통구멍과 막힌구멍의 tapping 및 모든 tap 작업 가능
- The tapping chuck is equipped with tension system by floating type.
- Easy and quick tool exchange.
- It is possible for tapping operation of blind hole and through hole.

Code No.	ød	øD	L	øC	L1		Weight (kg)
					F1	F2	
GBT30 - TCH12 - 125	19	44	100	35	6	12	1.2
GBT40 - TCH12 - 120	19	44	95	35	6	12	1.6
			125				1.9
TCH22 - 150	31	63	115	52	10	15	2.4
			177				3.0
GBT50 - TCH12 - 135	19	44	110	35	6	12	4.2
			140				4.8
			170				5.0
TCH22 - 165	31	63	132	52	10	15	5.7
			162				6.3
			192				6.9
TCH36 - 210	48	67	165	83	15	20	8.0
			195				8.5

- Rapid feed form approach point
- Tapping by pitch feed
- Stop spindle reversing
- Back feed
- Quick return

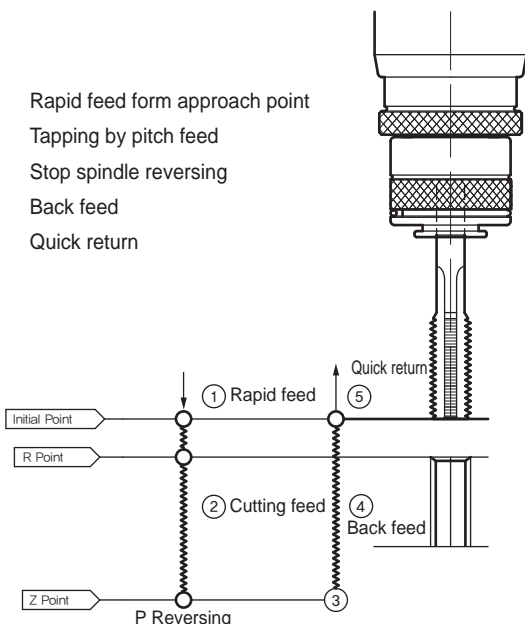

▶ 적용 탭콜릿은 P149

▶ Private tap collets are referred. P149

NC DRILL CHUCK

Clamping Range : $\phi 0.3 \sim \phi 13.0$



CODE No.

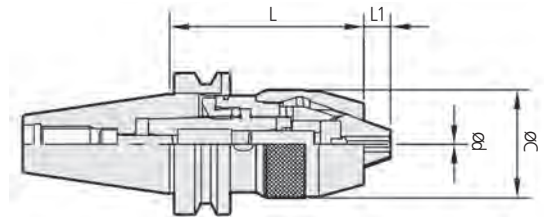
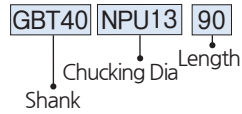

GBT Tooling System은 BT 2면구속 Spindle에서 2면구속으로 사용이 가능하며 일반 BT Spindle에서도 사용이 가능합니다.
 GBT Tooling System can be used as the double face contact with the double face contact spindle and also used with BT standard spindle.

PRODUCT INFORMATION

머시닝 센터의 일반적인 드릴링 공구입니다. General Drillings for Machining Centers

- 척과 샹크가 일체형 구조로 길이가 짧음
- 가공정도 향상과 우수한 내구성
- 척의 탈락이 없고 주축 정지시 풀리지 않음
- Unified body of chuck and shank reduces the length of tool.
- Improved operation accuracy and excellent rigidity
- The drillchuck is never detached from holder and is not released when the operation is stop.

Code No.	ϕd	ϕC	L	L1	Weight (kg)
GBT30 - NPU 8 - 80	0.3~8.0	38	80	8.5	0.8
NPU 13 - 105	1.0~13.0	50	105	11.5	1.5
GBT40 - NPU 8 - 75	0.3~8.0	38	75	8.5	1.3
- 105			105		1.6
- 150			150		2.0
NPU 13 - 90	1.0~13.0	50	90	11.5	1.7
- 130			130		2.0
- 175			175		2.4
GBT50 - NPU 8 - 85	0.3~8.0	38	85	8.5	3.8
- 120			120		4.0
- 150			150		4.4
- 170			170		4.8
NPU 13 - 105	1.0~13.0	50	105	11.5	4.4
- 130			130		4.6
- 190			190		5.4

Spare Parts		
Type	Basic	
	Chuck	Spanner
NPU 8	NPU 8	NPU08-SP
NPU13	NPU13	NPU13-SP

- ▶ 초경 드릴, 탭은 절대 사용을 금지해 주십시오.
- ▶ 절삭공구 최소 척킹 길이를 준수해 주시기 바랍니다.
 NPU8-20mm이상
 NPU13-30mm이상
- ▶ 스페너는 별매입니다.
- ▶ Please Prohibit use CARBIDE DRILL and CARBIDE TAP.
- ▶ Please follow minimum length of cutting tools.
 NPU8 : more 20mm
 NPU13 : more 30mm
- ▶ Spanner is ordered separately.

SIDE LOCK HOLDER

Coolant-through hole
Clamping Range : $\phi 6.0 \sim \phi 42.0$



CODE No.

GBT50 SLA32 105
Shank Chucking Dia Length



TAPER 접촉을 80% 이상 진동없음.

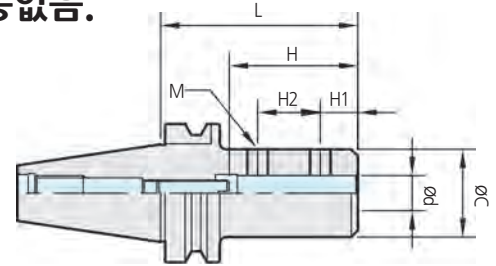

GBT Tooling System은 BT 2면구속 Spindle에서 2면구속으로 사용이 가능하며 일반 BT Spindle에서도 사용이 가능합니다.
GBT Tooling System can be used as the double face contact with the double face contact spindle and also used with BT standard spindle.

PRODUCT INFORMATION

- 드릴, 엔드밀 기타(Small chuck, Special tool)을 사용할 수 있습니다.
- SIDE LOCK HOLDER can use tool holder for drill, endmill, etc.

Code No.	ϕd	L	ϕC	L1		H1	H2	M	Weight (kg)
				Min	Max				
GBT30 - SLA 6 - 60	6	60	25	20	35	18	-	M 5	0.7
SLA 8 - 60	8		28	25	40			M 6	0.8
SLA10 - 75	10	75	35	35	45	14	15	M 8	0.9
SLA12 - 75	12		40	40	50			M10	1.0
SLA16 - 75	16		45	50	65	16	20	M12	1.1
SLA20 - 75	20	85	48	55	70	18	24	M14	1.2
SLA25 - 85	25								1.3
SLA32 - 105	32	105	58	65	80	20	22		1.5
GBT40 - SLA 6 - 75	6	75	25	20	35	20	-	M 5	1.2
SLA 8 - 75	8		30	25	40			18	M 6
SLA10 - 90	10	90	35	35	45	14	15	M 8	1.3
SLA12 - 90	12		40	40	50			16	M10
SLA16 - 90	16		45	50	65	20	M12	1.5	
SLA20 - 90	20		48	55	70	20	M14	1.8	
SLA25 - 90	25		48					2.0	
SLA32 - 90	32	105	62	65	80	25	25	M16	2.2
SLA40 - 105	40		72						2.5
SLA42 - 105	42		76	2.6					
GBT50 - SLA 6 - 90	6	90	25	20	35	18	-	M 5	3.7
SLA 8 - 90	8		28	25	40			M 6	3.9
SLA10 - 90	10	90	35	35	45	14	15	M 8	4.1
SLA12 - 90	12		40	40	50			16	M10
SLA16 - 90	16	105	45	50	65	20	M12	4.2	
- 105								4.4	
SLA20 - 105	20	135	48	60	75	20	M14	4.4	
- 135								4.6	
SLA25 - 105	25	105	48	60	75	20	M14	4.4	
- 135								4.7	
- 165								5.1	
SLA32 - 105	32	105	62	65	80	25	M16	4.8	
- 135		135						5.4	
- 165		165						6.2	
SLA40 - 105	40	105	76	65	80	25	M16	5.2	
- 135		135						5.5	
SLA42 - 105	42	105	80	65	80	25	M16	5.8	
- 135		135						6.0	

▶ 사이드락홀더 스페어 파트는 P64 ▶ The spare parts for SIDE LOCK HOLDER are referred. P64

MOLD SIDE LOCK HOLDER

Coolant-through hole
Clamping Range : $\phi 3.0 \sim \phi 32.0$



CODE No.
GBT50 | **MSL12** | **150** | **S**
 Shank | Chucking Dia | Length | Gage line not included



MAX
20,000
min⁻¹

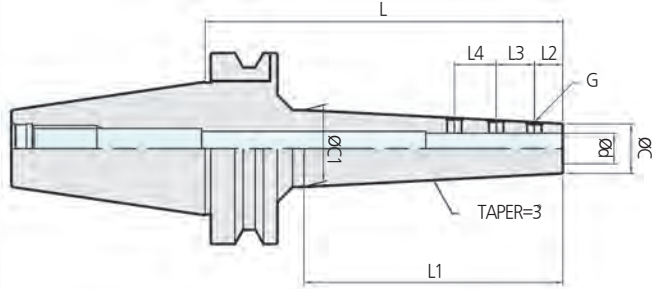

GBT Tooling System은 BT 2면구속 Spindle에서 2면구속으로 사용이 가능하며 일반 BT Spindle에서도 사용이 가능합니다.
 GBT Tooling System can be used as the double face contact with the double face contact spindle and also used with BT standard spindle.

PRODUCT INFORMATION

- 쉽고 빠른 공구교환
- 높은 정밀도
- 슬림한 디자인으로 간섭부위 최소화
- Easy and quick tool exchange.
- Excellent accuracy.
- Minimize interference area by slim design.

Code No.	ϕd	ϕC	$\phi C1$	L	L1	L2	L3	L4	G	MAX rpm	Weight (kg)
GBT40 - MSL 3 - 135	3	10	20	135	94	6	6	-	M3	20,000	1.3
MSL 4 - 135	4	11	21				7		M4		1.3
MSL 6 - 135	6	13	23				12		13		1.4
MSL 8 - 135	8	15	25				13.5		18		1.4
MSL10 - 150	10	17	29	150	109	15	20	M6	15,000	1.6	
MSL12 - 150	12	22	34				16			16	M8
GBT50 - MSL12 - 150S	12	22	37	188	136	16	16	M8	15,000	4.4	
- 200S			42	238	186					12,000	5.0
MSL16 - 150S	16	26	41	188	136	15	20	22	M8	15,000	4.6
- 200S			46	238	186					12,000	5.1
- 250S			51	288	236					10,000	5.9
MSL20 - 150S			20	30	45					188	136
- 200S	50	238			186	12,000	5.3				
- 250S	55	288			236	10,000	6.0				
MSL25 - 150S	25	35			50	188	136	15	20	22	M10
- 200S			55	238	186	12,000	5.4				
- 250S			60	288	236	10,000	6.2				
MSL32 - 150S			32	40	55	188	136				
- 200S	60	238			186	12,000	5.6				
- 250S	65	288			236	10,000	6.4				

- ▶ MSL홀더 볼트는 SELUX 전용 볼트를 사용하시기 바랍니다.
- ▶ 육각렌치는 별도 판매입니다.
- ▶ S Type는 표준길이(+38mm)
- ▶ Please only use SELUX private bolt for MSL HOLDER.
- ▶ Wrench is ordered separately.
- ▶ S type is extended by 38mm compare to standard type.

MSL BOLT

Item	Size	Length/pcs	chuck
MSL3 - BS	M3*0.5P	4mm / 2pcs.	MSL3
MSL4 - BS	M4*0.5P	4mm / 2pcs.	MSL4
MSL6 - BS	M6*0.75P	5, 6mm / 1pcs. Each	MSL6
MSL8 - BS		5, 6mm / 1pcs. Each	MSL8
MSL10 - BS	M8*0.75P	7mm / 1pcs. 8mm / 1pcs. 9mm / pcs.	MSL10
MSL12 - BS		7mm / 1pcs. 8mm / 1pcs. 9mm / pcs.	MSL12
MSL16 - BS		7mm / 1pcs. 8mm / 1pcs. 9mm / pcs.	MSL16
MSL20 - BS	M10*10P	7mm / 1pcs. 8mm / 1pcs. 9mm / pcs.	MSL20
MSL25 - BS		7mm / 1pcs. 8mm / 1pcs. 9mm / pcs.	MSL25
MSL32 - BS		6mm / 1pcs. 7mm / 1pcs. 8mm / pcs.	MSL32

MORSE TAPER HOLDER

■ for Morse taper shank with tang.



CODE No.

GBT50 MTA1 45

Shank Morse Taper No. Length

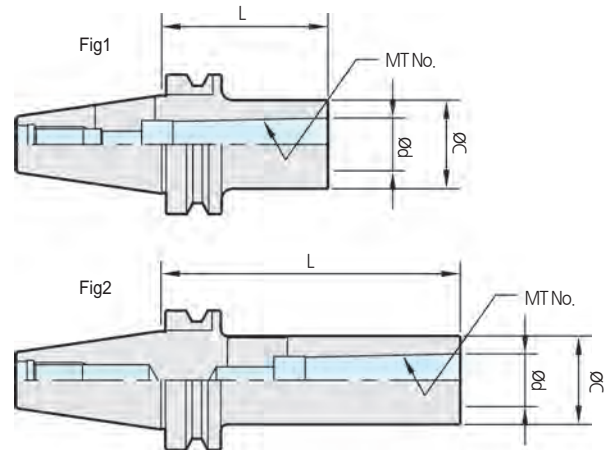

TAPER 접촉을 80% 이상 진동없음.

GBT Tooling System은 BT 2면구속 Spindle에서 2면구속으로 사용이 가능하며 일반 BT Spindle에서도 사용이 가능합니다.
 GBT Tooling System can be used as the double face contact with the double face contact spindle and also used with BT standard spindle.

PRODUCT INFORMATION

■ Drill, reamer, 기타(MT Shank type tool)등을 사용할 수 있습니다.

■ MORSE TAPER HOLDER can use tool holder for drill, reamer, etc.

Code No.	ød	MT No.	L	øC	Fig	Weight (kg)
GBT30 - MTA1 - 45	12.065	1	45	25	1	0.5
MTA2 - 60	17.780	2	60	32		0.5
MTA3 - 80	23.825	3	80	40		0.5
GBT40 - MTA1 - 45	12.065	1	45	25	1	1.0
- 120			120		2	1.3
MTA2 - 60			60		1	1.0
- 120	17.780	2	120	32	2	1.5
MTA3 - 75	23.825	3	75	40	1	1.0
- 135			135		2	1.7
MTA4 - 95	31.267	4	95	50	1	1.6
- 165			165		2	1.7
GBT50 - MTA1 - 45			12.065		1	45
- 120	120	2		4.2		
- 180	180	2		4.3		
MTA2 - 45	17.780	2	45	32	1	3.9
- 135			135		2	4.3
- 180			180		2	4.6
MTA3 - 45	23.825	3	45	40	1	3.8
- 150			150		2	4.6
- 180			180		2	4.9
MTA4 - 75	31.267	4	75	50	1	3.9
- 180			180		2	5.4
MTA5 - 105			44.399		5	105
- 210	210	2		7.2		

Drill Dia and Shank

Shank		MT1	MT2	MT3	MT4	MT5
Drill dia	Min	3.0	14.5	23.5	32.0	51.0
	Max	14.0	23.0	31.5	50.0	76.0

FACE MILL ARBOR



GBT SHANK
FACE MILL ARBOR



CODE No.

GBT50 FMA25.4 45
Shank Cutter Type Length

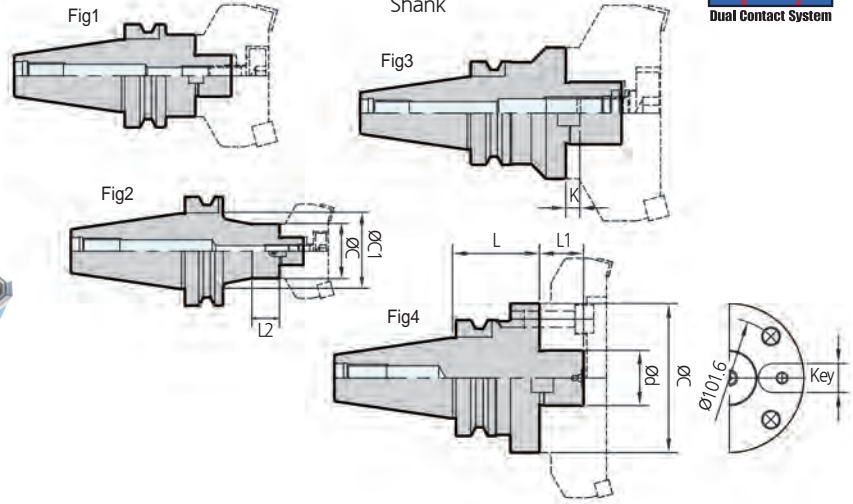

GBT Tooling System은 BT 2면구속 Spindle에서 2면구속으로 사용이 가능하며 일반 BT Spindle에서도 사용이 가능합니다.
GBT Tooling System can be used as the double face contact with the double face contact spindle and also used with BT standard spindle.

PRODUCT INFORMATION

■ JIS B4113 face milling용 입니다. ■ For face-milling cutter conforming to JIS B4113.

Code No.	ød	Cutter Dia	L	øC	øC1	L1	L2	Key	K	Fig	Weight (kg)						
GBT30 - FMA25.4 - 45	25.4	80	45	50	-	22	-	K9.5 - S	5	3	0.8						
			-	60								K12.7 - S	7				
- FMA31.75 - 45	31.75	100	-	-	-	30	-	-	-	-	1.0						
GBT40 - FMA25.4 - 45	25.4	80	45	50	-	22	-	K9.5 - S	5	1	1.4						
			-	90								K9.5 - L	5	3.0			
- 90	-	-	-	-	-	-	-	-	-	-	-						
FMA31.75 - 45	31.75	100	45	60	-	30	-	K12.7 - S	7	1	2.0						
- 75			75	K12.7 - S								7	3.2				
- 75			75	K12.7 - S								7	3.2				
FMA38.1 - 60	38.1	125	60	80	-	34	-	K15.85 - S	9	3	3.8						
GBT50 - FMA25.4 - 45	25.4	80	45	50	-	22	-	K9.5 - S	5	1	3.8						
			- 90									90	60	25	K9.5 - L	2	4.5
			- 150									150	70	25	K9.5 - L	2	5.5
FMA31.75 - 45	31.75	100	45	60	-	30	-	K12.7 - S	7	1	4.6						
			- 75									75	-	-	K12.7 - L	7	5.2
			- 105									105	70	25	K12.7 - L	2	5.5
			- 150									150	70	25	K12.7 - L	2	7.0
FMA38.1 - 45	38.1	125	45	80	-	34	-	K15.85 - S	9	1	4.3						
			- 75									75	-	-	K15.85 - L	9	5.0
			- 105									105	-	-	K15.85 - L	9	5.5
			- 150									150	-	-	K15.85 - L	9	8.5
FMA50.8 - 45	50.8	160	45	100	-	36	-	K19 - S	10	1	4.8						
			- 75									75	-	-	K19 - S	10	6.8
			- 105									105	-	-	K19 - S	10	7.8
FMA47.625 - 75	47.625	200	75	128.5	-	38	-	K25.4	12.5	4	7.6						

▶ 페이스밀아바 스페어 파츠는 P75

▶ The spare parts for FACE MILL ARBOR are referred. P75

FACE MILL ARBOR

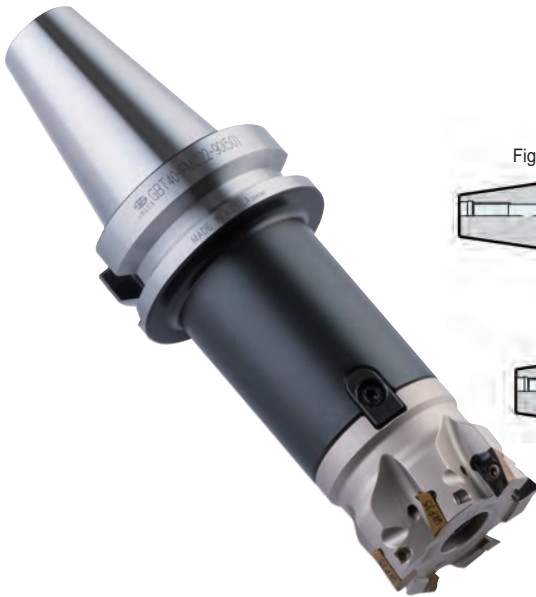

CODE No.

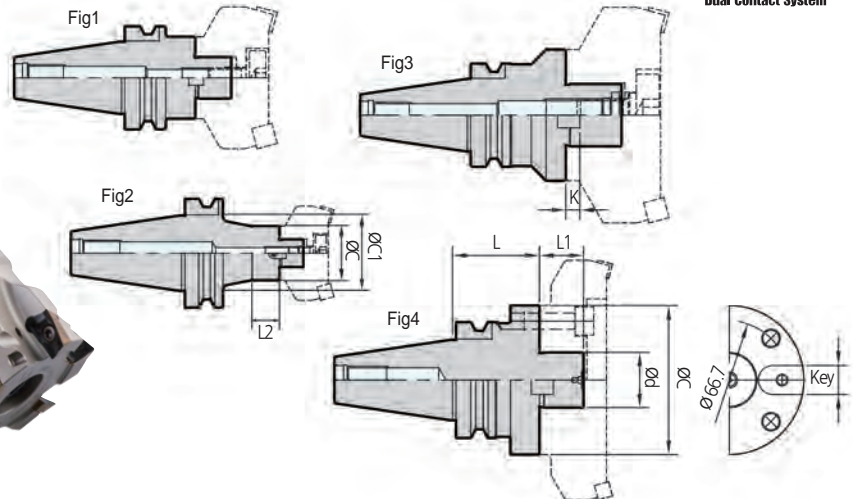
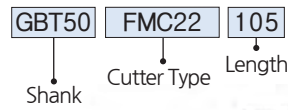

GBT Tooling System은 BT 2면구속 Spindle에서 2면구속으로 사용이 가능하며 일반 BT Spindle에서도 사용이 가능합니다.
 GBT Tooling System can be used as the double face contact with the double face contact spindle and also used with BT standard spindle.

PRODUCT INFORMATION

- JIS B4113 face milling용 입니다. ■ For face-milling cutter conforming to JIS B4113.
- (S)Type은 표준길이(+38mm) ■ S type is extended by 38mm compare to standard type.

Code No.	ød	Cutter Dia	L	øC	øC1	L1	L2	Key	K	Fig	Weight (kg)						
GBT30 - FMC16 - 45	16	40	45	38	-	16	-	K8-S	5	1	1.2						
			90	45				K10-S	5.5		1.5						
	27	63/80	45	60				K12-S	6		1.5						
			90	80				K14-S	7		2.0						
GBT40 - FMC16 - 45	16	40	45	38	-	16	-	K8-S	5	1	1.7						
			90	45				K10-S	5.5		2.0						
	25.4	63/80	60	70				K9.5-S	6		2.5						
			90	60				K12-S			2.7						
27	63/80	60	60	K12-L	1	2.5											
		90	60	K12-L		3.4											
FMC27 - 60	32	100	60	80	-	22	-	K14-S	7	3	3.4						
			90	80				K14-L			3.8						
	38.1	100	60	85				K15.85-S			7	4.7					
			90	85				K15.85-L				5.0					
FMC40 - 60	40	125/160	60	90	-	26	-	K15.85-S	8	4	5.2						
			90	90				K15.85-S			5.2						
	GBT50 - FMC16 - 60	16	40	60				38			-	16	-	K8-S	5.0	1	3.2
				90				45						K10-S			5.5
- 105	22	50/63	105	45	48	18	-	K10-L	5.5	2				7.3			
			150	58										63			25
FMC25.4 - 45	25.4	63/80	45	70	-	20	-	K9.5-S	6	1	4.1						
			90	70				K9.5-L			6.0						
			150	60				K12-S			5.0						
			45	60				K12-L			6.0						
FMC27 - 45	27	63/80	45	60	-	20	-	K12-S	6	1	5.0						
			90	60				K12-L			7.5						
			150(63)	68				K14-S			7.5						
			150(80)	68				K14-S			5.0						
FMC32 - 45	32	100	45	80	-	22	-	K14-S	7	1	6.0						
			75	80				K14-L			6.8						
			105	80				K14-L			9.8						
			150	80				K14-L			6.8						
FMC38.1 - 45	38.1	100	45	85	-	22	-	K15.85-S	7	1	5.8						
			75	85				K15.85-S			6.0						
			105	85				K15.85-L			7.0						
			150	85				K15.85-L			7.0						
FMC40 - 45	40	125/160	45	90	-	26	-	K15.85-S	8	4	6.2						
			75	90				K15.85-L			6.8						

▶ 페이스밀아바 스페어 파트는 P75

▶ The spare parts for FACE MILL ARBOR are referred. P75

FACE MILL ARBOR (COOLANT TYPE)

GBT SHANK

FACE MILL ARBOR (COOLANT TYPE)

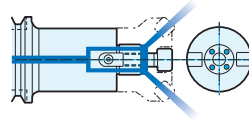

CODE No.

GBT50 FMH22 105
Shank Cutter Type Length

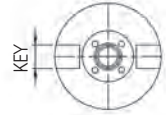
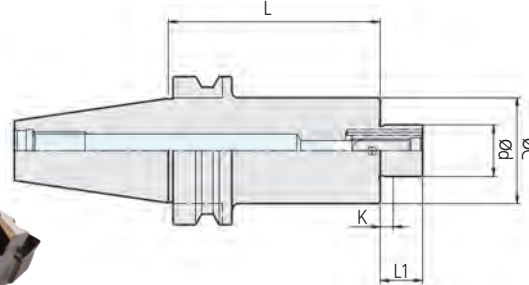

GBT Tooling System은 BT 2면구속 Spindle에서 2면구속으로 사용이 가능하며 일반 BT Spindle에서도 사용이 가능합니다.
GBT Tooling System can be used as the double face contact with the double face contact spindle and also used with BT standard spindle.

PRODUCT INFORMATION

- 쿨런트 컷터 전용
- 컷터 가공성 향상 및 공구사용시간 증가
- Only use coolant cutter.
- Improve tool life and cutting operation.

Code No.	ød	øC	L	L1	K	KEY	Weight (kg)
GBT30 - FMH16 - 45	16	38	45	16	5	K8-S	1.2
FMH22 - 45	22	45		90	18	5.5	K10-S
- 90							
FMH27 - 45	27	60	45	20	6	K12-S	1.5
GBT40 - FMH16 - 45	16	38	45	16	5	K8-S	1.7
FMH22 - 45	22	45		90	18	5.5	K10-S
- 90							
FMH27 - 60	27	60	60	20	6	K12-S	2.5
- 90			90			K12-L	3.4
FMH32 - 60	32	80	60	22	7	K14-S	3.4
FMH25.4 - 60	25.4	70	60	20	6	K9.5-S	2.5
- 90							90
FMH31.75 - 60	31.75	76	60	30	7	K12.7-S	2.7
- 90			90				3.2
FMH38.1 - 60	38.1	85	60	34	9	K15.85-S	4.7
- 90			90			K15.85-L	5.0
- 150			150			K10-S	3.6
GBT50 - FMH22 - 60	22	45	60	18	5.5	K10-S	5.5
- 105			105				7.3
- 150			150				7.5
FMH27 - 90	27	60	90	20	6	K12-L	6.0
- 150			150				7.5
FMH32 - 90	32	80	90	22	7	K14-L	6.5
- 150			150				9.0
FMH25.4 - 90	25.4	70	90	20	6	K9.5-L	6.0
- 150			150				7.9
FMH31.75 - 90	31.75	76	90	30	7	K12.7-L	6.5
- 150			150				8.2
FMH38.1 - 90	38.1	85	90	34	9	K15.85-L	7.0
- 150			150				9.0

▶ FMH 클램프볼트 및 부품은 일반 FMA, FMC 아바와 호환합니다.
▶ 페이스밀아바 스페어 파트는 P75

▶ FMH clamp bolt and other parts is compatible with FACE MILL ARBOR FMA, FMC.
▶ The spare parts for FACE MILL ARBOR are referred. P75

PRO MILL ARBOR



CODE No.

GBT50 M06 135
Shank Cutter Type Length

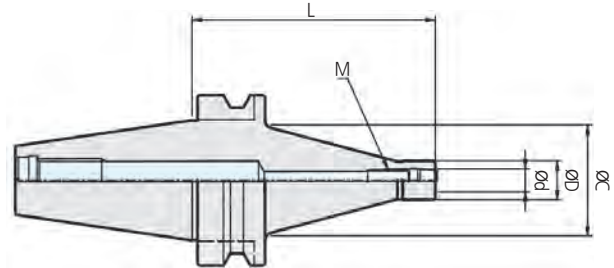

GBT Tooling System은 BT 2면구속 Spindle에서 2면구속으로 사용이 가능하며 일반 BT Spindle에서도 사용이 가능합니다.
GBT Tooling System can be used as the double face contact with the double face contact spindle and also used with BT standard spindle.

PRODUCT INFORMATION

- 모듈라 방식으로 원가 절감
- 높은 정밀도
- 이면구속 체결로 흔들림 감소
- 헤드 교체로 다양한 작업가능
- Cost reduction effect with modular system.
- Excellent accuracy.
- Vibration damping effect due to dual face contact.
- A various operation with exchanging head.

Code No.	ød	L	øD	øC	M	Weight (kg)	
GBT40 - M06 - 90	6.5	90	10	40	M6	1.2	
		120				1.5	
M08 - 90	8.5	90	14.4		M8	1.2	
		120				1.5	
M10 - 90	10.5	90	18		M10	1.3	
		120				1.5	
		150				1.9	
M12 - 120	12.5	120	22.5		M12	1.5	
		150				1.9	
GBT50 - M06 - 135	6.5	135	10		65	M6	4.2
		165					4.9
M08 - 135	8.5	135	14.4			M8	4.2
		165		4.9			
M10 - 135	10.5	135	18	M10		4.2	
		165				4.9	
		135				4.2	
M12 - 135	12.5	135	22.5	M12		4.2	
		165				4.9	

PRO MILL CUTTER(Ball Type)

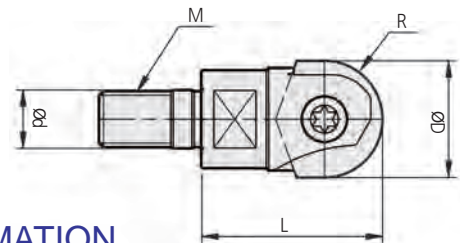

PRODUCT INFORMATION

- HITACHI 인서트 호환
- 정삭 R작업 최적화
- Compatible with HITACHI insert.
- Optimal for R-finishing operation.

Code No.	R	øD	L	ød	M	Insert	Screw	Wrench
R05M0630	5	10	30	6.5	M6	ZPFG100, ZCFW100	TNS-5842	TXL-10
R06M0630	6	12				ZPFG120, ZCFW120	TNS-5843	TXT-20
R08M0830	8	16	35	8.5	M8	ZPFG160, ZCFW160	TNS-5844	
R10M1035	10	20				ZPFG200, ZCFW200	TNS-5845	TXT-25
R12M1240	12.5	25	40	12.5	M12	ZPFG250, ZCFW250	TNS-5846	TXT-30

- ▶ 다양한 Type의 커터 제작가능합니다.
- ▶ 전용 스패너는 별매입니다.

- ▶ Cutters can be made of a variety of Type.
- ▶ Spanner is orderd seperately.

SIDE CUTTER ARBOR

GBT SHANK
SIDE CUTTER ARBOR



CODE No.

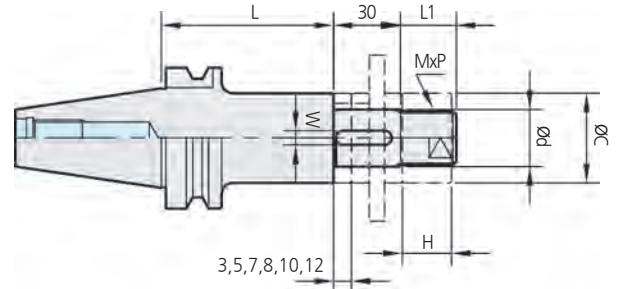
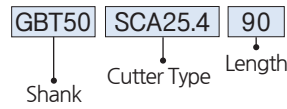

GBT Tooling System은 BT 2면구속 Spindle에서 2면구속으로 사용이 가능하며 일반 BT Spindle에서도 사용이 가능합니다.
 GBT Tooling System can be used as the double face contact with the double face contact spindle and also used with BT standard spindle.

PRODUCT INFORMATION

- JIS B4219,4109,4107 side cutter type 입니다. ■ For side cutters conforming to JIS B4219, 4019, and 4107.
- Key, collar 및 nut는 부착되어 있습니다. ■ Key, collar and nut attached.

Code No.	ød	L	øC	L1	W	H	M x P	Weight (kg)
GBT30 - SCA25.4 - 60	25.4	60	40	25	6.35	21	M24X1.5	0.9
GBT40 - SCA25.4 - 75	25.4	75	40	25	6.35	21	M24X1.5	2.1
		120						2.5
SCA31.75 - 90	31.75	90	46	30	7.93	26	M30X1.5	2.6
		120						2.9
GBT50 - SCA25.4 - 90	25.4	90	40	25	6.35	21	M24X1.5	4.7
		135						5.0
SCA31.75 - 90	31.75	90	46	30	7.93	26	M30X1.5	5.1
		135						5.7
SCA38.1 - 90	38.1	90	55	36	9.53	31	M36X1.5	5.8
		135						6.8

Spare Parts			
Type	Parallel Key	Coller	Lock Nut
SCA25.4	6.35 x 6.35 x 25	SCA25.4 -Set	SCA-M24
SCA31.75	7.92 x 7 x 25	SCA31.75 -Set	SCA-M30
SCA38.1	9.52 x 8 x 25	SCA38.1 -Set	SCA-M36

Excellent Precision
Excellent Quality

SELUX
NC TOOLING SYSTEM

BT

CHUCK & Item

HYDRAULIC CHUCK
MILLING CHUCK
HIGH SPEED MILLING CHUCK
MILLING CHUCK SET
SHRINK FIT HOLDER
SSK COLLET CHUCK
HIGH SPEED GSK CHUCK
ER COLLET CHUCK
ENDMILL COLLET CHUCK
ER SLIM COLLET CHUCK
SYNCRO TAPPING CHUCK
TAPPING CHUCK HOLDER
NC DRILL CHUCK
SIDE LOCK HOLDER
LONG TYPE SIDE LOCK HOLDER
MOLD SIDE LOCK HOLDER
MSL BOLT
JACOBS TAPER ARBOR
MORSE TAPER HOLDER
FACE MILL ARBOR
LONG TYPE FACE MILL ARBOR
FACE MILL ARBOR
FACE MILL ARBOR SPARE PARTS
PRO MILL ARBOR
PRO MILL ARBOR CUTTER
SIDE CUTTER ARBOR
CUTTER HOLDER
SQUARE BORING BAR



HYDRAULIC CHUCK

Coolant-through hole
Clamping Range : $\phi 3.0 \sim \phi 32.0$



CODE No.

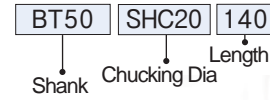

MAX
25,000
min⁻¹

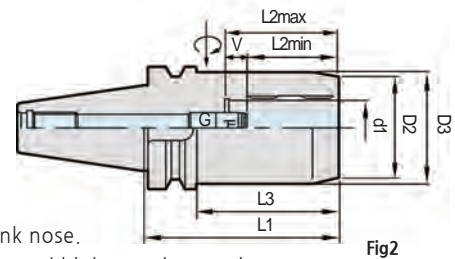
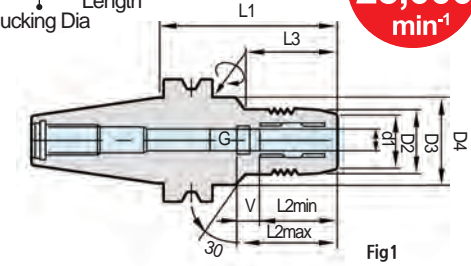

PRODUCT INFORMATION

- 4D 선단에서 3 μ m이내의 흔들림정도
- 높은 정밀도와 고속가공에 최적화
- 유압방식의 강력한 파지력
- 렌치 하나로 쉽게 공구고정
- 3 μ m(T.I.R) Run-out at 4D away from shank nose.
- The optimal chck for excellent accuracy and high speed operation.
- Powerful clamping force of hydraulic type.
- Easy clamping with just one wrench.

CODE NO.	d1	D2	D3	D4	L1	L2min	L2max	V	L3	G	Type	Weight (kg)		
BT30 - SHC 6 - 70	6	25	28	45	70	27.5	37.5	10	28	M5X0.8	Fig1	0.65		
SHC 8 - 70	8	27	30		75				32.5			42.5	38	
SHC10 - 75	10	29	32						85	37.5		47.5	36	M6X1.0
SHC12 - 75	12	31	34		90	42.5	52.5						44	
SHC14 - 85	14	33	36						90	42.5		52.5	48	M8X1.0
SHC16 - 90	16	35	38		90	42.5	52.5						48	
SHC18 - 90	18	38	41						-	-		-		-
SHC20 - 90	20	40	42	-	-	-	-	-	-	0.90				
BT40 - SHC 6 - 65	6	25	28	50	65	27.5	37.5	10	23	M5X0.8	Fig1	1.0		
- 90					90				75			42.5	44	M6X1.0
- 140					140					23			1.9	
SHC 8 - 65	8	27	30		65	32.5	42.5		39	M6X1.0		1.0		
- 90									90			44	1.3	
- 140									140	23		1.9		
SHC10 - 65	10	29	32		65	37.5	47.5		23	M6X1.0		1.1		
- 90									90			44	1.35	
- 140									140	23		1.95		
SHC12 - 65	12	31	34		65	42.5	52.5		23	M6X1.0		1.1		
- 90									90			44	1.35	
- 140									140	23		1.96		
SHC14 - 65	14	33	36		65	37.5	47.5		23	M6X1.0		1.2		
- 90									90			44	1.35	
- 140									140	23		1.96		
SHC16 - 65	16	35	38	65	42.5	52.5	23	M8X1.0	1.15					
- 90							90		48	1.4				
- 140							140	30	1.96					
SHC18 - 75	18	38	41	75	42.5	52.5	30	M8X1.0	1.15					
- 90							90		48	1.45				
- 140							140	30	1.98					
SHC20 - 75	20	40	43	75	51	61	30	M16X1.0	1.2					
- 90							90		73	1.7				
- 140							140	108	2.3					
SHC25 - 100	25	53	57	100	55	65	-	M16X1.0	2.1					
- 135							-		-	2.6				
SHC32 - 105							32	58	63	135	55	65	-	-
- 135	-	-	-	-	-									

BT SHANK
HYDRAULIC CHUCK

HYDRAULIC CHUCK



Coolant-through hole
Clamping Range : $\phi 3.0 \sim \phi 32.0$

CODE No.

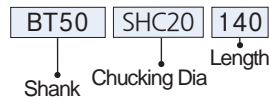

MAX
25,000
min⁻¹

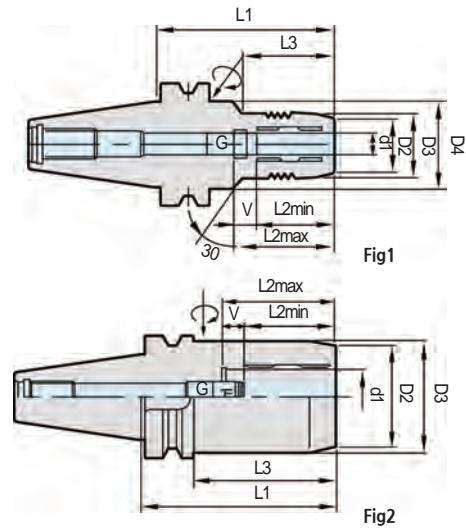

CODE NO.	d1	D2	D3	D4	L1	L2min	L2max	V	L3	G	Type	Weight (kg)
BT50 - SHC 6 - 90	6	25	28	50	90	27.5	37.5	10	32	M5X0.8	Fig1	3.75
					120				44			4.1
					140				44			4.7
SHC 8 - 90	8	27	30		90	37.5	47.5		32	3.75		
					120				40	4.1		
					140				44	4.7		
SHC10 - 90	10	29	32		90	32.5	42.5		32	3.9		
					120				44	4.3		
					140				44	4.9		
SHC12 - 90	12	31	34		90	37.5	47.5		32	3.9		
					120				44	4.3		
					140				44	4.9		
SHC14 - 90	14	33	36		90	42.5	52.5		32	3.9		
					120				44	4.3		
					140				44	4.9		
SHC16 - 90	16	35	38	90	51	61	32	4.0				
				120			48	4.4				
				140			48	5.0				
SHC18 - 90	18	38	41	90	55	65	32	4.0				
				120			48	4.4				
				140			48	5.0				
SHC20 - 90	20	40	43	90	51	61	32	4.0				
				120			48	4.4				
				140			48	5.0				
SHC25 - 105	25	53	57	105	51	61	67	4.4				
				150			112	5.6				
				150			77	4.7				
SHC32 - 115	32	58	63	115	55	65	77	4.7				
				150			112	6.0				
				150			112	6.0				

- ▶ 유압척 사용시 절삭공구 Shank공차는 h6 안에 들어오는 절삭공구 사용을 권장합니다.
- ▶ 유압척 SHC12, SHC20, SHC32는 D또는 OD콜릿을 사용하여 다양하게 공구를 척킹 할 수 있습니다.
- ▶ 유압척 전용 콜릿은 P138~P139
- ▶ 황삭작업에는 권장하지 않습니다.

- ▶ Tolerance of cutting tool shank should be configured within h6.
- ▶ HYDRAURIC CHUCK SHC12, SHC20, SHC32 are possible to use various shank cutting tool with D or OD COLLET.
- ▶ HYDRAURIC COLLET are refered. P138~P139
- ▶ We do not recommend to use hydraulic chuck for roughing operation.

ID	Wrench
SHC 6~20 ϕ	4mm
SHC 25~30 ϕ	5mm

BT SHANK HYDRAULIC CHUCK

MILLING CHUCK

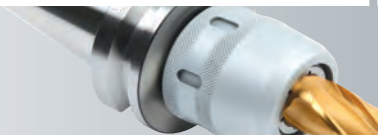

Coolant-through hole
Clamping Range : $\phi 3.0 \sim \phi 42.0$

CODE No.
BT50 MC32 105
Shank Chucking Dia Length

BT SHANK
MILLING CHUCK

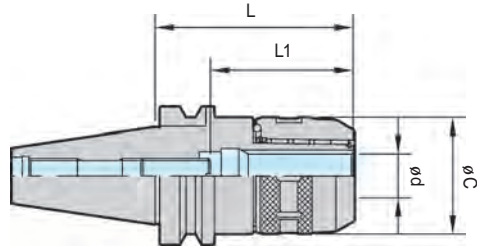
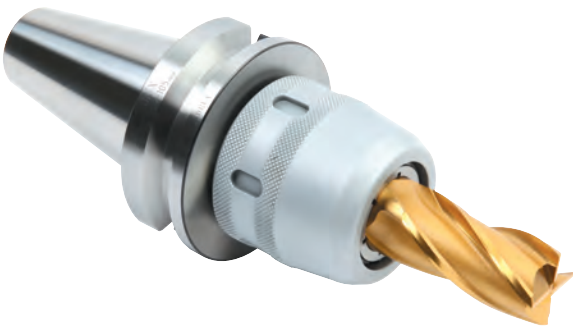

PRODUCT INFORMATION

- 높은 정밀도
- 간편한 척킹 시스템
- Taper 접촉 80% 이상 Taper공차 AT3로 보증
- 완전한 단면 밀착으로 강력 절삭
- 4배열 Roller System 방식으로 강력한 파지력
- Excellent Run-out Accuracy.
- Easy chucking system.
- More than 80% taper contact, we guarantee taper tolerance AT3.
- The strongest cutting power due to perfect face contact construction.
- Powerful clamping force by 4 needle roller system.

CODE NO.	ϕd	L	ϕC	L1	Collet	Weight (kg)	
BT30 - MC 20 - 80	20	75	53	70	K20, NC20	1.0	
MC 25 - 80	25	80	62		K25, NC25	1.2	
MC 32 - 100	32	100	72		K32, NC32	1.4	
BT40 - MC 20 - 80	20	80	53	82	K20, NC20	1.5	
90		90				1.6	
105		105				1.7	
120		120				1.9	
MC 25 - 80	25	80	62	90	K25, NC25	2.1	
90		90				2.2	
105		105				2.4	
120		120				2.7	
MC 32 - 85	32	85	72	80	K32, NC32	2.0	
105		105				90	2.4
120		120				105	2.7

Spare Parts		
Type	Option	
	Collet	Spanner
MC20	K20-NC20	MC20-SP(50-55)
MC25	K25-NC25	MC25-SP(56-61)
MC32	K32-NC32	MC32-SP(68-75)
MC42	K42-NC42	MC42-SP(88-96)

- ▶ 고속 바란스 작업시 추가 비용이 청구됩니다.
- ▶ 밀링척은 콜릿을 사용하여 다양한 Shank의 공구들을 체결할 수 있습니다.
- ▶ 밀링척 전용 콜릿은 P140~P143
- ▶ 밀링척 스패너는 별도 판매품 입니다. P157
- ▶ Extra charge for high speed balance.
- ▶ MILLING CHUCK is possible to use cutting tools of a various shank with COLLET.
- ▶ K-COLLET are referred. P140~P143
- ▶ Spanner is ordered separately. P157

MILLING CHUCK

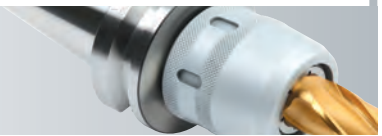

Coolant-through hole
Clamping Range : $\phi 3.0 \sim \phi 42.0$

CODE No.
BT50 MC32 105
Shank Chucking Dia Length

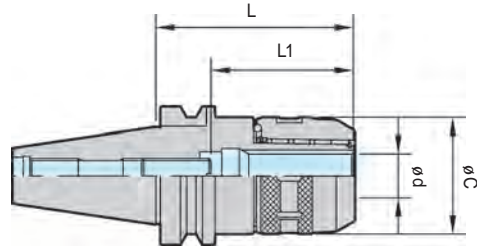
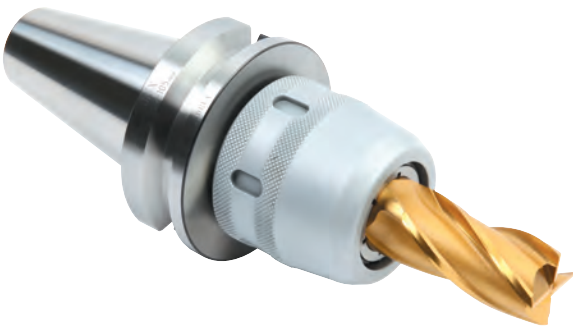

PRODUCT INFORMATION

- 높은 정밀도
- 간편한 척킹 시스템
- Taper 접촉 80% 이상 Taper 공차 AT3로 보증
- 완전한 단면 밀착으로 강력 절삭
- 4배열 Roller System 방식으로 강력한 파지력
- Excellent Run-out Accuracy.
- Easy chucking system.
- More than 80% taper contact, we guarantee taper tolerance AT3.
- The strongest cutting power due to perfect face contact construction.
- Powerful clamping force by 4 needle roller system.

CODE NO.	ϕd	L	ϕC	L1	Collet	Weight (kg)				
BT50 - MC 20 - 90	20	90	53	82	K20, NC20	4.1				
		105				4.4				
		120				4.6				
		135				4.8				
		165				5.3				
		200				6.0				
		250				7.5				
		300				9.5				
MC 25 - 90	25	90	62	90	K25, NC25	4.5				
		105				4.8				
		120				5.0				
		135				5.2				
		165				5.6				
		200				6.5				
		250				8.0				
		300				10.0				
MC 32 - 95	32	95	74	105	K32, NC32	4.7				
		105		110		4.9				
		120		125		5.3				
		135				5.7				
		165				6.5				
		200				7.5				
		250				9.2				
		300				10.6				
		350		12.5						
		400		15.0						
		MC 42 - 105		42		105	94	120	K42, NC42	5.5
						120		125		6.2
135	130		6.9							
165	135		8.3							
200			9.5							
250			11.8							
300			14.0							
350	17.5									
400	19.2									

BT SHANK MILLING CHUCK

HIGH SPEED MILLING CHUCK

Coolant-through hole
Clamping Range : $\phi 3.0 \sim \phi 32.0$

CODE No.

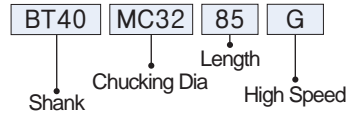

MAX
25,000
min⁻¹

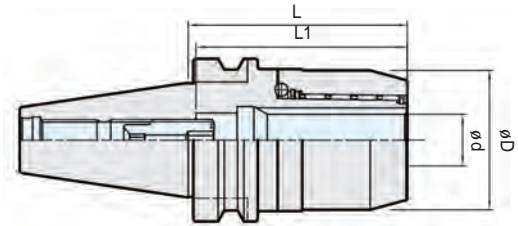

PRODUCT INFORMATION

- 고속 가공에서 높은 정도
- 강력한 파지력
- 스패너는 GH 스패너 사용(별매)
- G6.3 max 25,000RPM
- 원형너트로 고속 절삭시 소음 감소
- Excellent Run-out Accuracy.
- Powerful clamping force.
- GH spanner is orderd seperately.
- G6.3 max 25,000 RPM.
- The operation noise is reduced by assembled circle style nut.

CODE NO.	φd	L	φC	L1	Collet	MAX rpm	Weight (kg)
BT30 - MC20 - 80G	20	80	48	70	K20, NC20	25,000	0.6
MC25 - 80G	25	80	55		K25, NC25		0.9
BT40 - MC20 - 80G	20	80	48	82	K20, NC20	25,000	1.3
- 90G		90					1.4
MC25 - 80G	25	80	55	85	K25, NC25	20,000	1.5
- 90G		90					1.6
MC32 - 85G	32	85	68	80	K32, NC32		1.6
- 105G		105		90			2.0
BT50 - MC20 - 105G	20	105	48	105	K20, NC20	20,000	4.1
- 135G		135					4.4
MC25 - 105G	25	105	55	90	K25, NC25	15,000	4.4
- 135G		135					4.8
MC32 - 105G	32	105	68	110	K32, NC32		4.7
- 135G		135		135			5.2

Spare Parts		
Type	Option	
	Collet	Spanner
MC20-G	K20-NC20	MC20-GH
MC25-G	K25-NC25	MC25-GH
MC32-G	K32-NC32	MC32-GH

- ▶ 고속밀링척은 콜릿을 사용하여 다양한 Shank의 공구들을 체결할 수 있습니다. ▶ High speed MILLING CHUCK is possible to use cutting tools of a various shank with COLLET.
- ▶ 밀링척 전용 콜릿은 P140 ~ P143 ▶ K-COLLET is refered. P140~P143
- ▶ 고속밀링척 GH스패너는 별도 판매품 입니다. P157 ▶ GH SPANNER for high speed milling chuck is ordered seperately. P157

BT SHANK HIGH SPEED MILLING CHUCK

MILLING CHUCK SET

Coolant-through hole
Clamping Range : $\phi 3.0 \sim \phi 42.0$

CODE No.

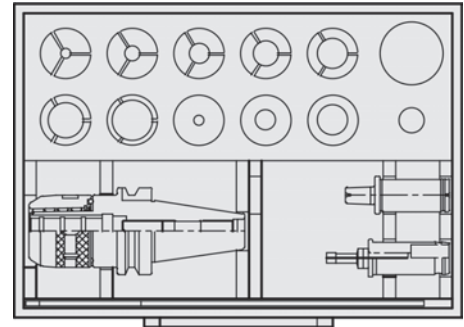
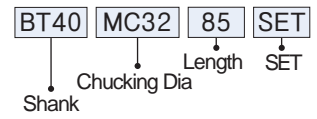

BT SHANK
MILLING CHUCK SET

PRODUCT INFORMATION

■ HSK/SK SET는 주문제작 합니다. ■ HSK/SK is available for request.

Code No.	Body	K- Collet	MT collet	JT Collet	Spanner
BT40-MC32- 85 SET	BT40-MC32-85	K32-6,8,10,12,16,20,25	K32-MT1,2,3	K32-JT6	MC32-SP
BT50-MC32-105 SET	BT50-MC32-105	K32-6,8,10,12,16,20,25	K32-MT1,2,3	K32-JT6	MC32-SP
BT50-MC42-105 SET	BT50-MC42-105	K42-6,8,10,12,16,20,25,32	K42-MT1,2,3,4	K42-JT6	MC42-SP

▶ 포장용 나무케이스는 별도로 판매하지 않습니다.
▶ GBT, HSK, CAT, SK 타입은 별도로 주문하셔야 됩니다.

▶ You can not order only wooden case for set.
▶ GBT, HSK, CAT, SK TYPE are ordered separately.

SHRINK FIT HOLDER



Coolant-through hole

Clamping Range : $\phi 3.0 \sim \phi 12.0$



CODE No.

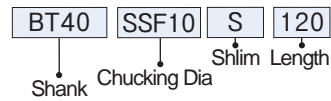

MAX
25,000
min⁻¹

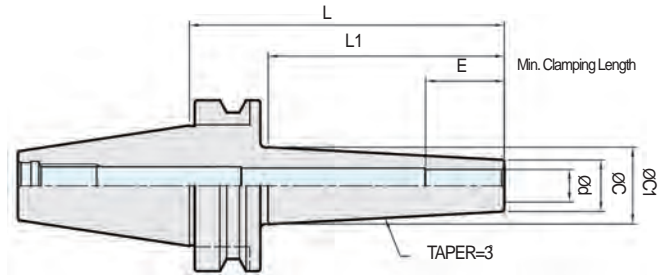

PRODUCT INFORMATION

- 4D선단에서 3 μ m이하의 흔들림 정도
- 높은 정밀도와 강력한 파지력
- 대칭적,슬림한 디자인으로 가공최적화
- 전제품 내부급유 (Coolant Through Hole)
- 3 μ m(T.I.R) Run-out at 4D away from shank nose.
- Excellent Run-out accuracy and powerful clamping.
- Optimal operation with slim and symmetrical design.
- All products can be used for center through coolant type.

Code No.	ϕd	ϕC	$\phi C1$	L	L1	E	Weight (kg)
BT30 - SSF 4S - 80	4	7	13	80	42	12	0.4
SSF 6S - 80	6	11	17		55	18	0.4
- 120			21	120	95	0.45	
SSF 8S - 80	8	13	19	80	55	24	0.4
- 120			23	120			95
SSF10S - 80	10	16	22	80	55	30	0.4
- 120			26	120			95
SSF12S - 80	12	19	25	80	55		0.5
- 120			29	120			95
BT40 - SSF 3S - 90	3	6	26	90	37	9	1.0
SSF 4S - 90	4	7				12	1.0
SSF 6S - 120	6	11	20	120	90	18	1.1
- 160			25	160			130
SSF 8S - 120	8	13	22	120	90	24	1.1
- 160			27	160			130
SSF10S - 120	10	16	25	120	90	30	1.1
- 160			30	160			130
SSF12S - 120	12	19	28	120	90		1.2
- 160			33	160			130
BT50 - SSF 6S - 120	6	11	19	120	79	18	3.8
- 160			23	160			119
SSF 8S - 120	8	13	21	120	79	24	3.8
- 160			25	160			119
SSF10S - 120	10	16	24	120	79	30	3.9
- 160			28	160			119
SSF12S - 120	12	19	27	120	79		3.9
-160			31	160			119

- ▶ 열박음홀더 사용시 절삭공구 Shank경은 h6의 제품을 사용해 주십시오.
- ▶ 절삭공구는 초경 Shank만 대응합니다. (하이스 제품 사용금지)
- ▶ 열박음홀더 사용시 지정된 고주파 히팅기를 사용해서 절삭공구 체결을 권장합니다.
- ▶ SELUX 고주파 히팅기는 P153
- ▶ 절삭공구 최소 삽입길이를 준수해 주시기 바랍니다.
- ▶ 공구길이조정 Stopper는 별도 판매 입니다. P153
- ▶ 열박음홀더 사용시 오일홀 풀스터드 볼트를 권장합니다.
- ▶ 열박음척 사용시 척 내경에 있는 방청유를 제거후에 사용하셔야 합니다. 내구성 저하 원인이 됩니다.

- ▶ Please use only carbide cutting tools of a shank tolerance within H6.
- ▶ Please use only carbide cutting tools for shrink fit holder. (Prohibit use HSS CUTTING TOOLS)
- ▶ We recommend shrink fit equipment when you use shrink fit holder.
- ▶ SELUX shrink fit equipment is referred. P153
- ▶ Please follow minimum insertion length of the cutting tools.
- ▶ Stopper for adjusting cutting tool length order separately. P153
- ▶ We recommend oil hole Pull stud bolt for shrink fit holder.
- ▶ Please clean the shank outside and inside of shrink fit before use. If you don't clean the shrink fit, it has problem about Run-out and toolife.

SHRINK FIT HOLDER



Coolant-through hole
Clamping Range : $\phi 3.0 \sim \phi 20.0$

CODE No.
BT40 SSF10 160
Shank Chucking Dia Length

MAX
25,000
min⁻¹

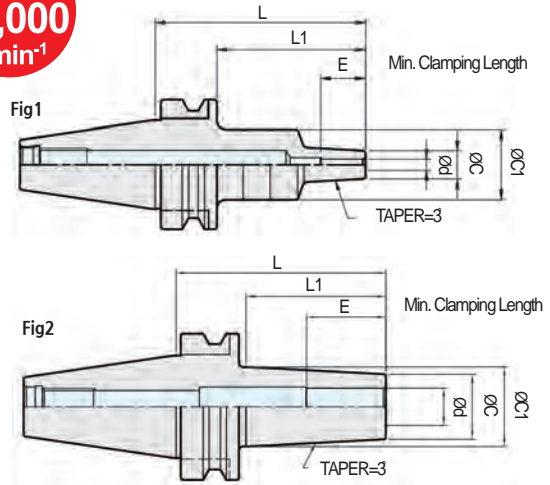

PRODUCT INFORMATION

- 4D선단에서 3 μ m이내의 흔들림 정도
- 높은 정밀도와 강력한 파지력
- 대칭적, 슬림한 디자인으로 가공최적화
- 전제품 내부급유 (Coolant Through Hole)
- 3 μ m(T.I.R) Run-out at 4D away from shank nose.
- Excellent Run-out accuracy and powerful clamping.
- Optimal operation with slim and symmetrical design.
- All products can be used for center through coolant type.

Code No.	ϕd	ϕC	$\phi C1$	L	L1	E	Fig	Weight (kg)
BT30 - SSF 3 - 75	3	7.5	25	75	53	12	1	0.5
SSF 4 - 75	4	10				16		0.5
SSF 6 - 75	6	12				24		0.5
SSF 8 - 75	8	14				26		0.5
SSF10 - 75	10	16				26		0.5
SSF12 - 75	12	20				30		0.5
SSF16 - 75	16	26	34	0.5				
BT40 - SSF 3 - 90	3	7.5	26	90	37	9	1	1.0
SSF 4 - 90	4	10				12		1.0
SSF 6 - 90	6	14	20	160	130	18	2	1.2
- 160			21					1.4
SSF 8 - 90	8	18	24	90	60	24	2	1.2
- 160			32					160
SSF10 - 90	10	22	28	90	60	30	2	1.3
- 160			36					160
SSF12 - 90	12	24	30	90	60	30	2	1.3
- 160			38					160
SSF16 - 90	16	28	34	90	60	34	2	1.3
- 160			42					160
SSF20 - 90	20	34	40	90	60	40	2	1.3
- 160			48					160
BT50 - SSF 6 - 100	6	14	20	100	59	18	2	3.7
- 160			26					160
SSF 8 - 100	8	18	24	100	59	24	2	3.7
- 160			30					160
SSF10 - 100	10	22	28	100	59	30	2	3.8
- 160			34					160
SSF12 - 100	12	24	30	100	59	30	2	3.8
- 160			36					160
SSF16 - 100	16	28	34	100	59	34	2	3.8
- 160			40					160
SSF20 - 100	20	34	46	100	59	40	2	3.9
- 160			53					160

SSK COLLET CHUCK



Coolant-through hole

Clamping Range : $\phi 1.0 \sim \phi 25.4$

CODE No.

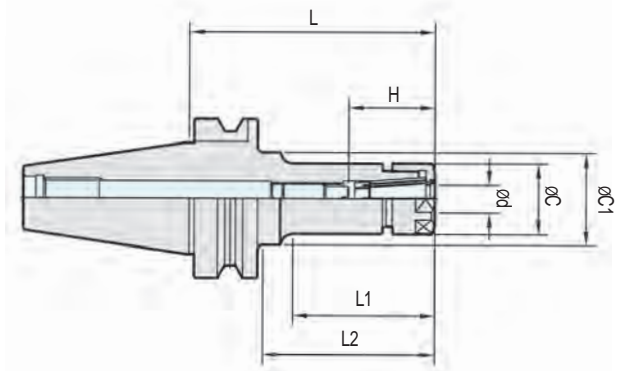
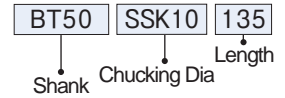

BT SHANK SSK COLLET CHUCK

PRODUCT INFORMATION

- 8Taper의 강력한 파지력
- 높은 정밀도와 빠른 가공에 적합
- 드릴, 센터드릴, 엔드밀, 탭, 리머용으로 사용
- Powerful clamping force of 8Taper.
- Excellent Run-out Accuracy.
- SSK COLLET CHUCK is suitable for a various operation using drill, endmill, tap and reamer.

Code No.	ϕd	L	ϕC	$\phi C1$	H		L1	L2	Collet	Weight (kg)	
					Min	Max					
BT30 - SSK 6 - 60	0.9~6.0	60	19.5	19.5	21	35	33	33	SC6	0.7	
		90		32			56	65		0.7	
SSK10 - 45	1.75~10.0	45	27.5	27.5	30	50	22	22	SC10	0.8	
		60					35	35		0.9	
		90					65	65		1.0	
		120					95	95		1.1	
SSK13 - 60	2.75~13.0	60	33	33	31	50	35	35	SC13	1.0	
		90					65	65		1.1	
		120					95	95		1.2	
SSK16 - 60	2.75~16.0	60	40	40	45	60	37	37	SC16	1.1	
		90					67	67		1.2	
		120					97	97		1.3	
SSK20 - 75	3.6~20.0	75	48	48	65	70	53	53	SC20	1.0	
		90					65	65		67	67
SSK25 - 90	16.0~25.4	90	55	55	55	75	67	67	SC25	1.5	
BT40 - SSK 6 - 60	0.9~6.0	60	19.5	19.5	21	35	30	30	SC6	1.0	
		90		32			51	60		1.1	
		120		60			60	90		1.4	
		150		25			60	120		1.5	
SSK10 - 60	1.75~10.0	60	27.5	27.5	30	50	32	32	SC10	1.1	
		90		40			48	60		1.2	
		120		73			90	148		1.4	
		150		34.5			118	148		1.6	
		180		39			148	148		1.6	
SSK13 - 60	2.75~13.0	60	33	33	31	65	28	28	SC13	1.2	
		90					58	58		88	1.4
		120					88	88		118	1.6
		150					118	118		148	1.8
		180					148	148		148	1.8
SSK16 - 60	2.75~16.0	60	40	40	50	65	32	32	SC16	1.3	
		90			40	67	58	58		1.5	
		120			40	70	88	88		1.7	
		150			118	118	148	148		1.9	
		180			148	148	148	148		2.0	
SSK20 - 60	3.6~20.0	60	48	48	47	60	32	32	SC20	1.3	
		90			47	80	60	60		1.6	
		120			47	80	90	90		2.0	
		150			47	90	118	118		2.4	
		180			47	90	148	148		2.9	

SSK COLLET CHUCK



Code No.	ød	L	øC	øC1	H		L1	L2	Collet	Weight (kg)	
					Min	Max					
BT40 - SSK25 - 75	16.0~25.4	75	55	55	40	60	46	46	SC25	1.5	
- 90		90			55	75	61	61		1.8	
- 120		120			55	85	91	91		2.0	
- 150		150			55	90	120	120		2.6	
- 180		180					150	150		3.1	
BT50 - SSK 6 - 105	0.9~6.0	105	19.5	32	21	35	55	64	SC6	3.8	
- 135		135					60	92		4.0	
- 165		165					60	114		4.2	
SSK10 - 105	1.75~10.0	105	27.5	27.5	30	50	57	57	SC10	4.2	
- 135		135		32			92	4.6			
- 165		165		36			70	114		4.8	
- 195		195					146	5.0			
- 225		225					178	5.2			
SSK13 - 105		2.75~13.0					105	33		31	65
- 135	135		45	92	92	4.7					
- 165	165			122	4.9						
- 195	195			152	5.2						
SSK16 - 105	2.75~16.0	105	40	40	40	70	62	62	SC16	4.7	
- 135		135		50			92	92		4.9	
- 165		165					122	5.1			
- 195		195					152	5.5			
SSK20 - 105		3.6~20.0					105	48		48	47
- 135	135		122	92	92	4.7					
- 165	165			122	5.0						
- 195	195			152	5.7						
SSK25 - 105	15.6~25.4			105	55	55	50		85		
- 135		135	92	92				5.4			
- 165		165	122	122				5.6			
- 195		195	152	152				6.0			

Spare Parts				
Type	Basic		Option	
	Nut	Adjust Screw	Spanner	Collet
SSK 6	SCN- 6 (HEXA)	BTD0825-C	SC 6-SP	SC 6-ø
SSK10	SCN-10 (HEXA)	BTD1225-C	SC10-SP	SC10-ø
SSK13	SCN-13	BTD1525-C	SC13-SP	SC13-ø
SSK16	SCN-16	BTD1830-C	SC16-SP	SC16-ø
SSK20	SCN-20	BTD2230-C	SC20-SP	SC20-ø
SSK25	SCN-25	BTD2838-C	SC25-SP	SC25-ø

- ▶ 너트, 조절나사 및 콜릿추출도구는 부속되어 있습니다.
- ▶ 스패너는 별매입니다. P157
- ▶ Synchronized Tap 사용시 SSK10을 사용하십시오.
Aluminum MAX Tapping M12
Steel MAX Tapping M10
Stainless Steel MAX Tapping M8
위 사양 이상인경우는 Milling Chuck에 K-Collet을 사용하시길 바랍니다.
- ▶ SSK척 콜릿은 P144~P145
- ▶ 절삭공구 체결시 무리한 힘이 가해질시 너트 및 홀더가 파손 될 수 있습니다.
- ▶ 고속 바란스 작업시 추가 비용이 청구됩니다.
- ▶ NUT, ADJUST SCREW, COLLET REMOVER are included.
- ▶ Spanner is ordered separately. P157
- ▶ Please use SSK10 when you use Synchronized Tap.
Aluminum MAX Tapping M12
Steel MAX Tapping M10
Stainless Steel MAX Tapping M8
If it has problem, We recommend K COLLET with Milling Chuck.
- ▶ SC COLLET is referred P144 ~ P145
- ▶ The nut or shank of chuck can be destoried if you too strongly clamp nut and holder.
- ▶ Extra charge for high speed balance.

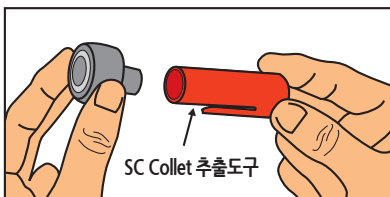

SSK NUT에 SC COLLET 체결시에는 전용 콜릿 추출도구를 사용하시기 바랍니다.
Please use private remover when you insert the SSK COLLET in SSK NUT

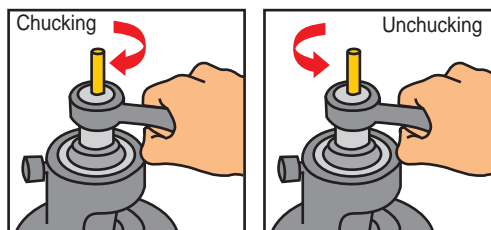

SSK Collet chuck은 Nut와 Body 체결시 40 Torque 이상의 힘이 가해질 시 너트 및 바디가 파손될 수 있습니다.
※주의 (SSK6, SSK10)
SSK NUT and SSK CHCUK is possible to be broken if you clamp chuck and nut over 40 Torque (※ WARNING SSK6, SSK10)

HIGH SPEED GSK CHUCK(P CLASS)

Coolant-through hole
Clamping Range : $\phi 1.0 \sim \phi 25.4$

CODE No.



MAX
40,000
min⁻¹

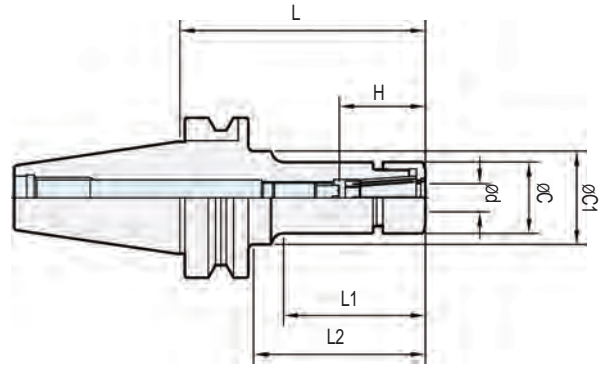

PRODUCT INFORMATION

- 고속가공에서 높은 정도
- 8°Taper의 강력한 파지력
- 원형 너트로 컴팩트한 디자인
- 스패너는 PH스패너 사용(별매)
- G2.5X max 40,000 RPM
- 고속형GSK척에는 P CLASS 콜릿 사용을 권장
- Excellent Run-out Accuracy.
- Powerful clamping force of 8°Taper
- Circle style nut designed compactly
- PH spanner is ordered seperately.
- G2.5X max 40,000 RPM.
- We recommed to use P CLASS SC COLLET when you use GSK CHCUK.

Code No.	ød	L	øC	øC1	H		L1	L2	Collet	MAX rpm	Weight (kg)			
					Min	Max								
BT30 - GSK 6 - 60P	0.9~6.0	60	19.5	19.5	21	35	33	33	SC6P	40,000	0.7			
		90		32							56	65	0.7	
		GSK10 - 60P		60							27.5	27.5	30	50
- 90P	90	95	95	1.1										
- 120P	120													
GSK13 - 60P	2.75~13.0	60	33	33	31	50	35	35	SC13P	1.0	1.0			
		- 90P									90	31	65	65
GSK16 - 60P	2.75~16.0	60	40	40	45	60	37	37	SC16P	30,000	1.1			
		- 90P									90	45	65	67
BT40 - GSK 6 - 60P	0.9~6.0	60	19.5	19.5	21	35	30	30	SC6P	25,000	1.0			
		90		32							51	60	1.1	
		120									60	90	1.4	
GSK10 - 60P	1.75~10.0	60	27.5	27.5	30	50	32	32	SC10P	1.1	1.1			
		- 90P		90							40	48	60	1.2
		- 120P		120							34.5	73	90	1.4
GSK13 - 60P	2.75~13.0	60	33	33	31	65	28	28	SC13P	1.2	1.2			
		- 90P									90	58	58	1.4
		- 120P									120	88	88	1.6
GSK16 - 60P	2.75~16.0	60	40	40	50	65	32	32	SC16P	1.3	1.3			
		- 90P			40	67	58	58			1.5			
		- 120P			120	40	70	88			88	1.7		
		- 150P			150			118			118	1.9		
GSK20 - 60P	3.6~20.0	60	48	48	47	60	32	32	SC20P	20,000	1.3			
		- 90P			47	80	60	60			1.6			
		- 120P			120			90			90	2.0		
GSK25 - 75P	15.6~25.4	75	55	55	40	60	46	46	SC25P	1.5	1.5			
		- 90P			55	75	61	61			1.8			
		- 120P			120	55	85	91			91	2.0		

BT SHANK HIGH SPEED GSK CHUCK(P CLASS)

HIGH SPEED GSK CHUCK(P CLASS)

Coolant-through hole

Clamping Range : $\phi 1.0 \sim \phi 25.4$

CODE No.

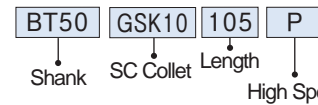

MAX
40,000
min⁻¹

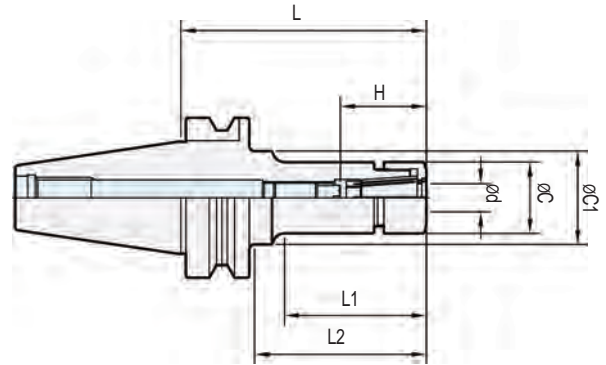

Code No.	ϕD	L	ϕC	$\phi C1$	H		L1	L2	Collet	MAX rpm	Weight (kg)
					Min	Max					
BT50 - GSK 6 - 105P	0.9~6.0	105	19.5	32	21	35	55	64	SC6P	20,000	3.8
- 135P		135									4.0
- 165P		165									4.2
GSK10 - 105P	1.75~10.0	105	27.5	30	50	57	57	SC10P	4.2		
- 135P		135							4.4		
- 165P		165							4.6		
GSK13 - 105P	2.75~13.0	105	33	31	65	62	62	SC13P	4.5		
- 135P		135							4.7		
- 165P		165							4.9		
GSK16 - 105P	2.75~16.0	105	40	40	70	62	62	SC16P	4.7		
- 135P		135							4.9		
- 165P		165							5.1		
GSK20 - 105P	3.6~20.0	105	48	48	47	80	62	62	SC20P	15,000	4.3
- 135P		135									4.6
- 165P		165									5.0
GSK25 - 105P	15.6~25.4	105	55	55	50	85	62	62	SC25P		5.2
- 135P		135									5.4
- 165P		165									5.6

Spare Parts				
Type	Basic		Option	
	Nut	Adjust Screw	Spanner	Collet
GSK 6P	SCN- 6P	BTD0825-C	SC 6-PH	SC 6- ϕ P
GSK10P	SCN-10P	BTD1225-C	SC10-PH	SC10- ϕ P
GSK13P	SCN-13P	BTD1525-C	SC13-PH	SC13- ϕ P
GSK16P	SCN-16P	BTD1830-C	SC16-PH	SC16- ϕ P
GSK20P	SCN-20P	BTD2230-C	SC20-PH	SC20- ϕ P
GSK25P	SCN-25P	BTD2838-C	SC25-PH	SC25- ϕ P

- ▶ 너트, 조절나사 및 콜렛추출도구는 부속되어 있습니다.
- ▶ 스페너는 별매입니다. P157
- ▶ GSK척 콜렛은 P144~P145
- ▶ 절삭공구 체결시 무리한 힘이 가해질시 너트및 홀더가 파손 될 수 있습니다.
- ▶ NUT, ADJUST SCREW, COLLET REMOVER are included.
- ▶ Spanner is ordered separately. P157
- ▶ P CLASS SC COLLET for GSK CHUCK is refered. P144 ~ P145
- ▶ It can be destoried nut or shank of chuck if you too strongly clamp nut and holder.

BT SHANK HIGH SPEED GSK CHUCK(P CLASS)

ER COLLET CHUCK

Coolant-through hole
Clamping Range : $\varnothing 0.5 \sim \varnothing 26.0$



CODE No.

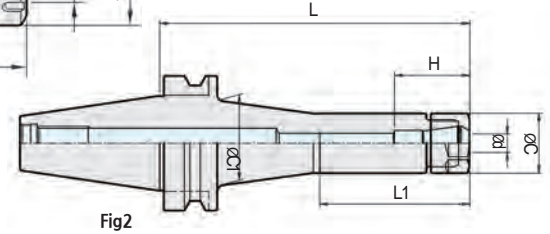
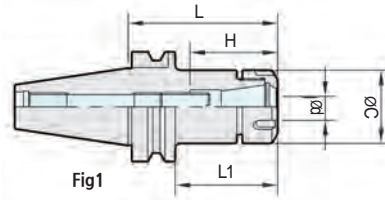
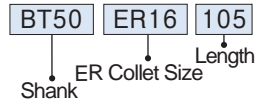

PRODUCT INFORMATION

- 안정적인 정밀도와 파지력
- 쉽고 빠른 공구교환
- 드릴, 엔드밀, 탭 다양한 사용범위
- Reliable accuracy and Powerful clamping force.
- Easy and quick tool exchange.
- ER COLLET CHUCK is suitable for a various operation using drill, endmill, tap.





Code No.	$\varnothing d$	L	L1	$\varnothing C$	C1	H		Collet	Fig	Weight (kg)
						Min	Max			
BT30 - ER11 - 60	0.5~7.0	60	35	19	-	19	34	ER11	1	0.5
- 75		75	50							0.5
- 90		90	65							0.6
ER16 - 60	0.5~10.0	60	35	28	-	23	43	ER16	1	0.5
- 75		75	50							0.5
- 90		90	65							0.6
ER20 - 60	1.0~13.0	60	35	35	-	25	48	ER20	1	0.5
- 75		75	50							0.6
- 90		90	65							0.7
ER25 - 60	1.0~16.0	60	35	42	-	34	54	ER25	1	0.6
- 75		75	50							0.7
- 90		90	65							0.8
ER32 - 60	2.0~20.0	60	35	50	-	40	60	ER32	1	0.5
- 75		75	50							0.7
- 90		90	65							0.9
BT40 - ER11 - 60	0.5~7.0	60	28	19	-	19	34	ER11	1	1.0
- 90		90	58		26				1.1	
- 120		120	65		26				1.2	
ER16 - 60	0.5~10.0	60	28	28	-	23	43	ER16	1	1.1
- 90		90	58		36				1.2	
- 120		120	73		40				1.3	
- 150		150	78		42				1.5	
- 180		180	85		42				1.8	
ER20 - 60	1.0~13.0	60	30	35	-	25	48	ER20	1	1.1
- 90		90	60		46				1.3	
- 120		120	90		46				1.5	
- 150		150	120		46				1.8	
- 180		180	86		46				2.0	
ER25 - 60	1.0~16.0	60	30	42	-	34	54	ER25	1	1.2
- 90		90	60		46				1.4	
- 120		120	90		46				1.6	
- 150		150	120		46				1.8	
- 180		180	150		46				2.2	
ER32 - 60	2.0~20.0	60	30	50	-	40	60	ER32	1	1.3
- 90		90	60		46				1.4	
- 120		120	90		46				1.7	
- 150		150	120		46				2.1	
- 180		180	150		46				2.5	
ER40 - 90	3.0~26.0	90	60	63	-	50	80	ER40	1	2.4
- 120		120	90		46				2.8	
- 150		150	120		46				3.2	

ER COLLET CHUCK

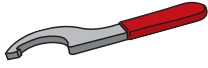

BT SHANK ER COLLET CHUCK

Code No.	ød	L	L1	øC	C1	H		Collet	Fig	Weight (kg)							
						Min	Max										
BT50 - ER11 - 75	0.5~7.0	75	34	19	-	19	34	ER11	1	3.6							
- 105		105	62							3.7							
- 135		135	61							3.8							
- 165		165								4.0							
ER16 - 75		75								34	28	-	28	43	ER16	1	3.8
- 105	105	62	4.0														
- 135	135	70	4.1														
- 165	165	77	4.2														
- 180	180		4.4														
ER20 - 75	1.0~13.0	75	34	35	-	35	48	ER20	1	3.8							
- 105		105	62							3.9							
- 135		135	92							4.1							
- 165		165	87							4.5							
- 180		180								4.6							
- 200		200	162							4.8							
- 250		250	212							1	5.1						
- 300		300	262								5.2						
ER25 - 75		1.0~16.0	75							34	42	-	42	54	ER25	1	3.9
- 105			105							62							4.1
- 135	135		92	4.3													
- 165	165		90	4.4													
- 180	180			4.6													
- 200	200		162	5.0													
- 250	250		212	1	6.0												
- 300	300		262		6.7												
- 350	350		342	7.0													
ER32 - 75	2.0~20.0		75	32	50	-	50	60	ER32	1							4.0
- 105		105	62	4.3													
- 135		135	92	4.9													
- 165		165	122	5.0													
- 180		180	137	5.3													
- 200		200	162	5.6													
- 250		250	212	6.5													
- 300		300	262	7.2													
- 350		350	342	8.0													
ER40 - 75		3.0~26.0	75	34							63	-	63	80	ER40	1	5.6
- 105	105		62	6.5													
- 135	135		92	7.2													
- 165	165		122	8.0													

Spare Parts				
Type	Option			
	NUT	Adjust Screw	Spanner	ER Collet
				
ER11	UM/ER11(HEXA)	BTD0716-C	ER11-SP	ER11-ø
ER16	UM/ER16(HEXA)	BTD1025-C	ER16-SP	ER16-ø
ER20	UM/ER20(HEXA)	BTD1325-C	ER20-SP	ER20-ø
ER25	UX/ER25	BTD1830-C	ER25-SP	ER25-ø
ER32	UX/ER32	BTD2230-C	ER32-SP	ER32-ø
ER40	UX/ER40	BTD2838-C	ER40-SP	ER40-ø

- ▶ 내부급유 사용시에는 방수형콜릿이나 방수형 너트를 사용 해주십시오. ▶ Please use waterproof collet and waterproof nut for operating centre through coolant type.
- ▶ ER콜릿은 P146 ▶ ER COLLET is referred. P16
- ▶ 스패너는 별매입니다. P157 ▶ Spanner is ordered separately. P157
- ▶ 고속 바란스 작업시 추가 비용이 청구됩니다. ▶ Extra charge for high speed balance.
- ▶ ER척 스페어 파트는 P56 ▶ The spare parts for ER CHCUK are referred. P56

ENDMILL COLLET CHUCK



Coolant-through hole
Clamping Range : $\phi 6.0 \sim \phi 20.0$

CODE No.

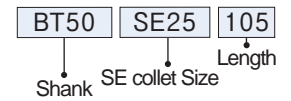

BT SHANK
ENDMILL COLLET CHUCK

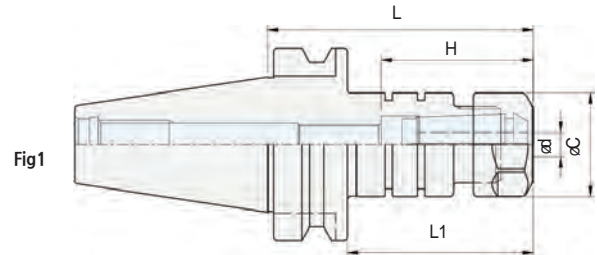

PRODUCT INFORMATION

- SE척 전용 콜릿 사용
- ENDMILL 전용 COLLET CHUCK
- 4도 TAPER의 강력한 파지력
- 5 μ m at 4D (T.I.R) (Max G2.5 at 20,000 rpm)
- Please use dedicated collet for SE COLLET CHUCK
- SE COLLET CHUCK for dedicated ENDMILL
- Strong Clamping Power of 4 degree TAPER
- 5 μ m at 4D (T.I.R) (Max G2.5 at 20,000 rpm)

CODE NO.	ϕd	ϕC	H	L	L1	Collet	Weight (kg)	Fig
BT40 - SE20 - 90	6,8,10,12	34	40.5	90	63	SE20	1	1
SE25 - 90	6,8,10,12,16	42	48			SE25	1.4	
SE32 - 90	6,8,10,12,16,20	50	58			SE32	1.5	
BT50 - SE20 - 105	6,8,10,12	34	40.5	105	67	SE20	1.6	
- 135				135	97		2	
- 165				165	127		2.4	
SE25 - 105	6,8,10,12,16	42	48	105	67	SE25	4.4	
- 135				135	97		4.8	
- 165				165	127		4.9	
SE32 - 105	6,8,10,12,16,20	50	58	105	67	SE32	5.7	
- 135				135	97		6.5	
- 165				165	127		5.5	

Spare Parts				
Type	Option			
	NUT	Adjust Screw	Spanner	SE Collet
SE20				
SE20	UM/SE20(HEXA)	BTD1325-C	SE20-SP	SE20- ϕ
SE25	UX/SE25	BTD1830-C	SE25-SP	SE25- ϕ
SE32	UX/SE32	BTD2230-C	SE32-SP	SE32- ϕ

- ▶ SE NUT와 ER NUT은 호환성이 있으나 SE너트로 별도 구매 바랍니다. (ER NUT를 SE CHUCK에 사용을 금지합니다.)
- ▶ 스패너는 별도 구매 입니다.
- ▶ SE콜릿은 P146
- ▶ Nut has compatible with SE NUT and ER NUT. But Please order separately when you need NUT. (Prohibit that SE CHUCK use ER NUT)
- ▶ Spanner is ordered separately
- ▶ SE COLLET is referred. P146

ER SLIM COLLET CHUCK



Coolant-through hole
Clamping Range : $\phi 0.5 \sim \phi 16.0$

CODE No.

BT50 ER25 M 105
Shank ER Collet Size Slim Length

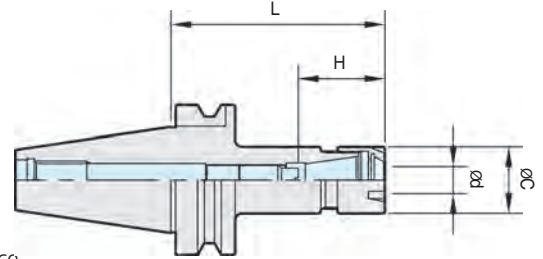





PRODUCT INFORMATION

- 좁고 깊은 곳에 적합
- 뛰어난 정밀도와 파지력
- 척킹 범위 $\phi 0.5\text{mm} \sim \phi 16.0\text{mm}$
- Narrow and depth place.
- High accuracy and Powerful clamping force.
- Chucking Dia $\phi 0.5\text{mm} \sim \phi 16.0\text{mm}$

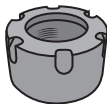
Code No.	ϕd	L	ϕC	H		Collet	Weight (kg)
				Min	Max		
BT30 - ER11M - 45	0.5~ 7.0	45	16	20	35	ER11	0.5
- 60		60					0.5
ER16M - 45		45					0.5
- 60	0.5~10.0	60	22	30	45	ER16	0.5
- 90		90					0.6
ER20M - 45		45					0.5
- 60	1.0~13.0	60	28	35	50	ER20	0.6
- 90		90					0.7
ER25M - 45		45					0.6
- 60	1.0~16.0	60	35	40	55	ER25	0.7
- 90		90					0.8
BT40 - ER11M - 60		60					1.0
- 90	0.5~ 7.0	90	16	20	35	ER11	1.0
- 120		120					1.1
ER16M - 60		60					1.1
- 90	0.5~10.0	90	22	30	45	ER16	1.1
- 120		120					1.2
ER20M - 60		60					1.2
- 90	1.0~13.0	90	28	35	50	ER20	1.1
- 120		120					1.2
ER25M - 75		75					1.2
- 90	1.0~16.0	90	35	40	55	ER25	1.2
- 120		120					1.3
BT50 - ER11M - 105		105					1.3
- 135	0.5~ 7.0	135	16	20	35	ER11	1.3
- 165		165					1.4
ER16M - 105		105					1.4
- 135	0.5~10.0	135	22	30	45	ER16	1.1
- 165		165					1.2
ER20M - 105		105					1.2
- 135	1.0~13.0	135	28	35	50	ER20	1.1
- 165		165					1.2
ER25M - 105		105					1.2
- 135	1.0~16.0	135	35	40	55	ER25	1.1
- 165		165					1.2
ER11M - 135		135					1.2
- 165	0.5~ 7.0	165	16	20	35	ER11	1.2
ER16M - 135		135					1.2
- 165		165					1.2
ER20M - 135	135	1.2					
- 165	1.0~13.0	165	28	35	50	ER20	1.2
ER25M - 135		135					1.2
- 165		165					1.2
ER11M - 165	165	1.2					
- 135	1.0~16.0	135	35	40	55	ER25	1.2
- 165		165					1.2
ER11M - 165		165					1.2

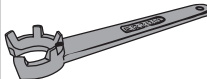
Spare Parts

Type	Basic		Option	
	NUT	Adjust Screw	Spanner	Collet
ER11M				
ER16M	SM/ER11M	BTD0716-C	ER11M-SP	ER11- ϕ
ER20M	SM/ER16M	BTD1025-C	ER16M-SP	ER16- ϕ
ER25M	SM/ER20M	BTD1325-C	ER20M-SP	ER20- ϕ
	SM/ER25M	BTD1830-C	ER25M-SP	ER25- ϕ

▶ ER콜릿은 P146
▶ 스페너는 별매입니다. P157

▶ ER COLLET is referred. P146
▶ Spanner is ordered separately. P157

SYNCHRO TAPPING CHUCK

Coolant-through hole
Clamping Range : M2.0 ~ M22.0

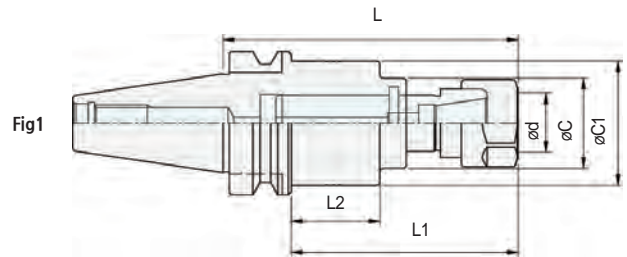
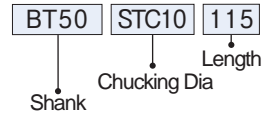

CODE No.



PRODUCT INFORMATION

- 고속 가공용 TAPPING CHUCK (Max. G6.3 at 10,000 rpm)
- 4D x 25 μ m(T.I.R)
- 특수 설계로 인한 TAP 파손 방지
- ER TAP COLLET 사용 권장 (STC3 은 일반 ER11 COLLET)
- TAPPING CHUCK for high speed. (Max. G6.3 at 10,000 rpm)
- 4D x 25 μ m(T.I.R)
- Special designed Tapping chuck for Tapping
- recommend ER TAP COLLET When you use Synchro tapping chuck (STC3 use ER11 collet)

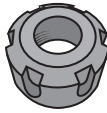
CODE NO.	ϕd	ϕC	$\phi C1$	L	L1	L2	Collet	Weight (kg)	Fig
BT30 - STC 3 - 80	M1~M3	36	25	80	58	22.5	ER11	0.6	1
STC 10 - 95	M2~M10	40	29	95	73	28.5	TER16	0.9	
BT40 - STC 10 - 100	M2~M10	40	29	100	73	28.5	TER16	1.3	
STC 22 - 115	M4~M22	54	42	115	88	28	TER32	1.4	
BT50 - STC 10 - 115	M2~M10	40	29	115	77	32.5	TER16	1.5	
STC 22 - 120	M4~M22	65	48	120	82	21	TER32	1.6	

Spare Parts			
Type	Option		
	NUT	Spanner	TER Collet
STC 3			
STC 10	UM/ER11(HEXA)	ER11-SP	ER11- ϕ
STC 22	UM/ER16(HEXA)	ER16-SP	TER16- ϕ
	UX/ER32	ER32-SP	TER32- ϕ

- ▶ 스페너는 별매입니다.
- ▶ 동기화 기능(리지드)이 있는 장비에서 사용 가능합니다.
- ▶ ER콜릿은 P146
- ▶ TER콜릿은 P148

- ▶ Spanner is ordered separately.
- ▶ The machining Center has Syncro function (RIGID TAP) to use STC CHUCK
- ▶ ER COLLET is referred. P146
- ▶ TER COLLET is referred. P148

TAPPING CHUCK HOLDER

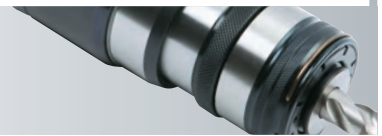

Tapping Range : M3 ~ M36

CODE No.

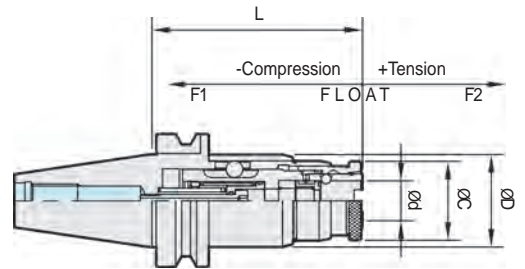
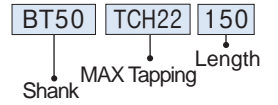

PRODUCT INFORMATION

- 플로팅 타입으로 인장수축 장치 내장
- 공구교환이 빠르고 편리함
- 관통구멍과 막힌구멍의 tapping 및 모든 tap 작업 가능

- The tapping chuck is equipped with tension system by floating type.
- Easy and quick tool exchange.
- It is possible for tapping operation of blind hole and through hole.

Code No.	ød	øD	L	øC	L1		Weight (kg)
					F1	F2	
BT30 - TCH12 - 125	19	44	100	35	6	12	1.2
BT40 - TCH12 - 120			95		6	12	1.6
- 150			125		6	12	1.9
TCH22 - 150	31	63	115	52	10	15	2.4
- 180			177		10	15	3.0
BT50 - TCH12 - 135			110		6	12	4.2
- 165	19	44	140	35	6	12	4.8
- 195			170		6	12	5.0
TCH22 - 165			132		10	15	5.7
- 195	31	63	162	52	10	15	6.3
- 225			192		10	15	6.9
TCH36 - 210			165		15	20	8.0
- 240	48	67	195	83	15	20	8.5

P149

Private tap collets are referred. P149

- ① Rapid feed form approach point
- ② Tapping by pitch feed
- ③ Stop spindle reversing
- ④ Back feed
- ⑤ Quick return

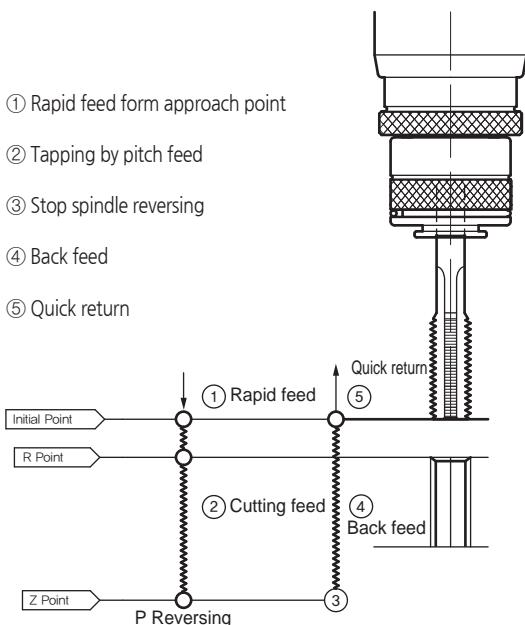

NC DRILL CHUCK

Clamping Range : $\varnothing 0.5 \sim \varnothing 13.0$

CODE No.

BT40 NPU13 90
 Shank Chucking Dia Length

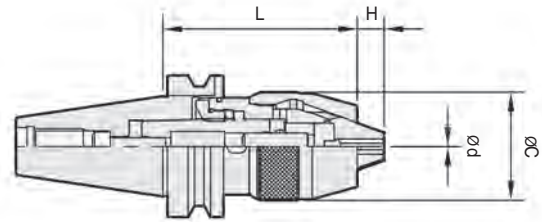

PRODUCT INFORMATION

머시닝 센터의 일반적인 드릴링 공구입니다. **General Drillings for Machining Centers**

- 척과 샤프트가 일체형 구조로 길이가 짧음
- 가공정도 향상과 우수한 내구성
- 척의 탈락이 없고 주축 정지시 풀리지 않음
- Unified body of chuck and shank reduces the length of tool.
- Improved operation accuracy and excellent rigidity
- The drillchuck is never detached from holder and is not released when the operation is stop.

Code No.	$\varnothing d$	L	$\varnothing C$	H	Weight (kg)
BT30 - NPU 8 - 80	0.3~8.0	80	38	8.5	0.8
NPU 13 - 105	1.0~13.0	105	50	11.5	1.5
BT40 - NPU 8 - 75	0.3~8.0	75	38	8.5	1.3
- 105		105			1.6
- 150		150			2.0
NPU13 - 90	1.0~13.0	90	50	11.5	1.7
- 130		130			2.0
- 175		175			2.4
BT50 - NPU 8 - 85	0.3~8.0	85	38	8.5	3.8
- 120		120			4.0
- 150		150			4.4
- 170		170			4.8
NPU 13 - 105	1.0~13.0	105	50	11.5	4.4
- 130		130			4.6
- 190		190			5.4

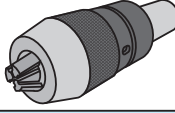
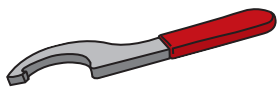
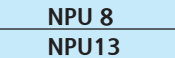
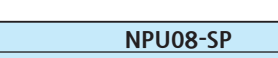
Spare Parts		
Type	Basic	
	Chuck	Spanner
NPU 8		
NPU13		
	NPU 8	NPU08-SP
	NPU13	NPU13-SP

- ▶ 초경 드릴, 탭은 절대 사용을 금지해 주십시오.
- ▶ 절삭공구 최소 척킹 길이를 준수해 주시기 바랍니다.
 NPU8-20mm이상
 NPU13-30mm이상
- ▶ 스패너는 별매입니다. P157

- ▶ Please Prohibit use CARBIDE DRILL and CARBIDE TAP.
- ▶ Please follow minimum length of cutting tools.
 NPU8 : more 20mm
 NPU13 : more 30mm
- ▶ Spanner is ordered separately. P157

SIDE LOCK HOLDER

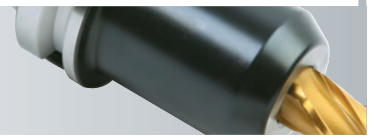

Coolant-through hole
Clamping Range : $\phi 6.0 \sim \phi 42.0$

CODE No.

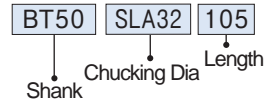

TAPER 접촉을 80% 이상 진동없음.

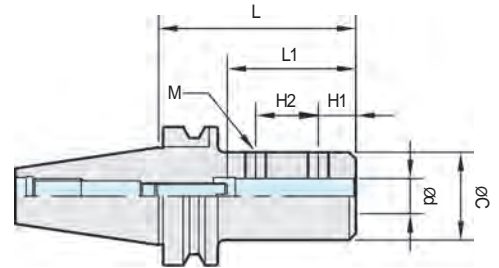
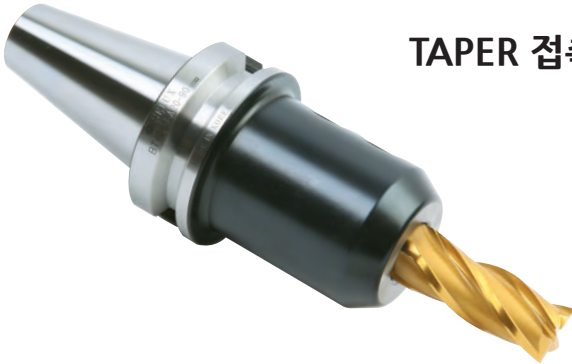

PRODUCT INFORMATION

■ 드릴, 엔드밀 기타(Small chuck, Special tool)을 사용 할 수 있습니다.

■ SIDE LOCK HOLDER can use tool holder for drill, endmill, etc.

Code No.	ϕd	L	ϕC	L1		H1	H2	M	Weight (kg)							
				Min	Max											
BT30 - SLA 6 - 60	6	60	25	20	35	18	-	M 5	0.7							
SLA 8 - 60	8		28	25	40			M 6	0.8							
SLA10 - 75	10		35	35	45			M 8	0.9							
SLA12 - 75	12	75	40	40	50	15	16	M10	1.0							
SLA16 - 75	16		45	50	65	16	20	M12	1.1							
SLA20 - 75	20		48	55	70	18		M14	1.2							
SLA25 - 85	25	85	48	55	70	18	24	M14	1.3							
SLA32 - 105	32	105					58		65	80	20	22	1.5			
BT40 - SLA 6 - 75	6	75	25	20	35	20	-	M 5	1.2							
SLA 8 - 75	8		30	25	40	18		M 6	1.2							
SLA10 - 90	10	90	35	35	45	14	15	M 8	1.3							
SLA12 - 90	12		40	40	50		16	M10	1.4							
SLA16 - 90	16		45	50	65		20	M12	1.5							
SLA20 - 90	20	90	48	55	70	25	20	M14	1.8							
SLA25 - 90	25								2.0							
SLA32 - 90	32								2.2							
SLA40 - 105	40	105	72	65	80	25	25	M16	2.5							
SLA42 - 105	42		76						2.6							
BT50 - SLA 6 - 90	6	90	25	20	35	18	-	M 5	3.7							
SLA 8 - 90	8		28	25	40			M 6	3.9							
SLA10 - 90	10		35	35	45			M 8	4.1							
SLA12 - 90	12	90	40	40	50	14	16	M10	4.2							
SLA16 - 90	16		45	50	65	20	M12	4.2								
- 105	16		105	45	50	65		20	4.4							
SLA20 - 105	20	105	48	60	75	25	20	M14	4.4							
- 135	20								135	4.6						
SLA25 - 105	25								105	4.4						
- 135	25	135	48	60	75	25	20	M14	4.7							
- 165	25	165	48	60	75	25	20	M14	5.1							
SLA32 - 105	32	105	62	65	80	25	25	M16	4.8							
- 135	32								135	62	65	80	25	25	M16	5.4
- 165	32								165	62	65	80	25	25	M16	6.2
SLA40 - 105	40	105	76	65	80	25	25	M16	5.2							
- 135	40								135	76	65	80	25	25	M16	5.5
SLA42 - 105	42	105	80	65	80	25	25	M16	5.8							
- 135	42								135	80	65	80	25	25	M16	6.0

▶ 사이드락홀더 스페어 파트는 P64

▶ The spare parts for SIDE LOCK HOLDER are referred. P64

LONG TYPE SIDE LOCK HOLDER

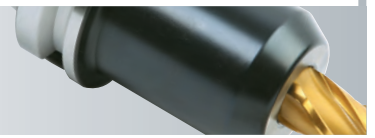

Coolant-through hole
Clamping Range : $\phi 6.0 \sim \phi 63.0$

CODE No.

BT50	SLA32	200
Shank	Chucking Dia	Length

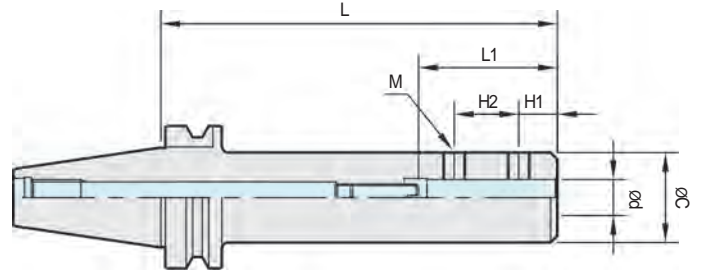

PRODUCT INFORMATION

- drill, endmill, 기타(small chuck, special tool) 등을 사용 할 수 있습니다. ■ SIDE LOCK HOLDER can use tool holder for drill, endmill, etc.
- ⊙ Saddle pin type(DIN1835C) endmill용 입니다. ⊙ Saddle pin type(DIN1835C) endmill type.

Code No.	ϕd	L	ϕC	L1		H1	H2	M	Weight (kg)
				Min	Max				
BT50 - SLA 6 - 105	6	105	25	20	35	18	-	M 5	4.4
- 150		150							5.3
- 200		200							5.8
- 250		250							6.5
* - 300		300							1.3
* - 350		350							6.2
SLA 8 - 105	8	105	28	25	40	20	M 6	4.4	
- 150		150						5.3	
- 200		200						5.8	
- 250		250						6.5	
* - 300		300						7.3	
* - 350		350						8.3	
SLA10 - 105	10	105	35	35	45	14	15	M 8	4.4
- 150		150							5.3
- 200		200							5.8
- 250		250							6.6
* - 300		300							7.5
* - 350		350							8.5
SLA12 - 105	12	105	40	40	50	15	16	M10	4.4
- 150		150							5.3
- 200		200							5.9
- 250		250							6.8
* - 300		300							7.8
* - 350		350							8.8
SLA16 - 150	16	150	45	50	65	16	20	M12	4.8
- 200		200							5.6
- 250		250							6.2
* - 300		300							7.1
* - 350		350							8.2
* - 400		400							9.8
SLA20 - 150	20	150	48	60	75	18	M14	4.8	
- 200		200						5.6	
- 250		250						6.2	
* - 300		300						7.1	
* - 350		350						8.3	
* - 400		400						10.0	

- ▶ 사이드락홀더 스페어 파트는 P64 ▶ The spare parts for SIDE LOCK HOLDER are referred. P64
- ▶ * 표시된 제품은 센터홀이 없습니다. ▶ " * " indicate that it does not have centre through hole.

BT SHANK LONG TYPE SIDE LOCK HOLDER

LONG TYPE SIDE LOCK HOLDER

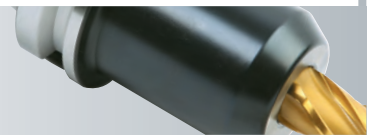

Coolant-through hole
Clamping Range : $\phi 6.0 \sim \phi 63.0$

CODE No.

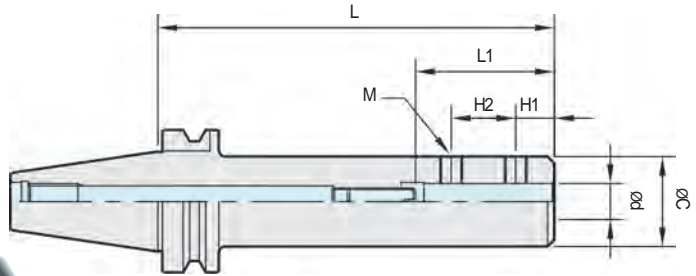
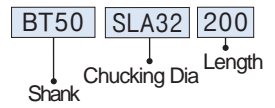

PRODUCT INFORMATION

■ drill, endmill, 기타(small chuck, special tool) 등을 사용 할 수 있습니다.
 ○ Saddle pin type(DIN1835C) endmill용 입니다.

■ Side lock holder is using as a tool hilder for drill, endmill, ETC.
 ○ Saddle pin type(DIN1835C) endmill type.

Code No.	ϕd	L	ϕC	L1		H1	H2	M	Weight (kg)
				Min	Max				
BT50 - SLA25 - 150	25	150	48	60	75	25	20	M14	4.8
- 200		200							5.6
- 250		250							6.8
* - 300		300							7.9
* - 350		350							8.9
* - 400		400							10.8
SLA32 - 150	32	150	62	65	82	25	25	M16	5.6
- 200		200							6.8
- 250		250							7.9
* - 300		300							8.9
* - 350		350							11.0
* - 400		400							14.0
SLA40 - 150	40	150	76	65	82	25	25	M16	5.8
- 200		200							7.0
- 250		250							8.1
* - 300		300							9.0
* - 350		350							12.1
* - 400		400							15.0
SLA42 - 150	42	150	80	65	80	25	25	M16	6.0
- 200		200							7.2
- 250		250							8.9
* - 300		300							9.8
* - 350		350							13.0
* - 400		400							17.0
SLA50 - 105	50	105	88	50	82	25	28	M18	6.4
- 150		150							8.2
- 200		200							9.8
- 250		250							10.9
* - 300		300							14.5
* - 350		350							18.0
* - 400	400	22.0							
SLA50.8 - 121	50.8	121	95	50	84	34	36	M20	5.0

▶ 사이드락홀더 스페어 파트는 P64
 ▶ * 표시된 제품은 센터홀이 없습니다.

▶ The spare parts for SIDE LOCK HOLDER are refered. P64
 ▶ " * " indicate that it does not have centre through hole.

BT SHANK LONG TYPE SIDE LOCK HOLDER

LONG TYPE SIDE LOCK HOLDER

Coolant-through hole
Clamping Range : $\phi 6.0 \sim \phi 63.0$

CODE No.

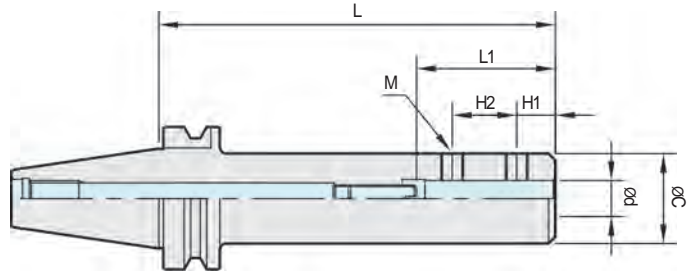

BT50	SLA32	200
Shank	Chucking Dia	Length





PRODUCT INFORMATION

■ drill, endmill, 기타(small chuck, special tool) 등을 사용할 수 있습니다.
⊕ Saddle pin type(DIN1835C) endmill용 입니다.

■ Side lock holder is using as a tool holder for drill, endmill, ETC.
⊕ Saddle pin type(DIN1835C) endmill type.

Type	Spare Parts	
	Basic	
	Set Screw	Adjust Screw
		
SLA 6	BT0510	BN0520-C
SLA 8	BT0610	BN0625-C
SLA10	BT0812	BN0825-C
SLA12	BT1014	BN1030-C
SLA14	BT1212	BN1030-C
SLA16	BT1414	BN1240-C
SLA20	BT1414	BN1240-C
SLA25	BT1414	BN1240-C
SLA32	BT1616	BN1240-C
SLA40	BT1616	BN1240-C
SLA42	BT1616	BN1240-C
SLA50	BT2020	BN1240-C
SLA50.8	BT2020	-

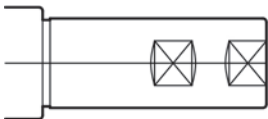
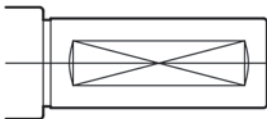
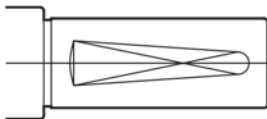
Purpose

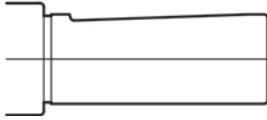
Weldon Shank	Flst Shank	Whistel Notch Shank
		
		

BT SHANK
LONG TYPE SIDE LOCK HOLDER

MOLD SIDE LOCK HOLDER

Coolant-through hole
Clamping Range : $\phi 3.0 \sim \phi 32.0$



CODE No.

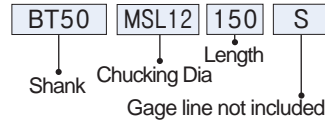

MAX
20,000
min⁻¹

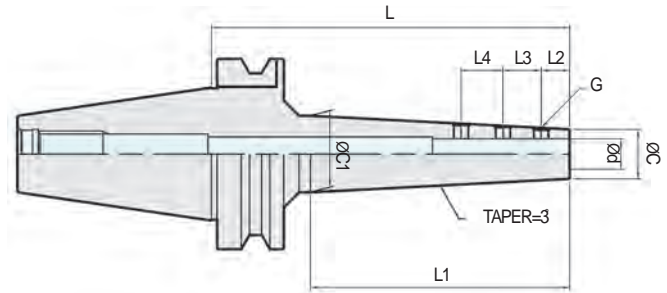

BT SHANK MOLD SIDE LOCK HOLDER

PRODUCT INFORMATION

- 쉽고 빠른 공구교환
- Easy and quick tool exchange.
- 높은 정밀도
- Excellent accuracy.
- 슬림한 디자인으로 간섭부위 최소화
- Minimize interference area by slim design.

Code No.	ϕd	ϕC	$\phi C1$	L	L1	L2	L3	L4	G	MAX rpm	Weight (kg)
BT40 - MSL 3 - 135	3	10	20	135	94	6	6	-	M3	20,000	1.3
MSL 4 - 135	4	11	21				7		M4		1.3
MSL 6 - 135	6	13	23				12		13		1.4
MSL 8 - 135	8	15	25				13.5		18		M6
MSL10 - 150	10	17	29	150	109	15	20	16	M8	15,000	1.6
MSL12 - 150	12	22	34				16			16	1.7
BT50 - MSL12 - 150S	12	22	37	188	136	15	16	16	M8	15,000	4.4
- 200S			42	238	186					12,000	5.0
MSL16 - 150S	16	26	41	188	136	15	20	22	M8	15,000	4.6
- 200S			46	238	186					12,000	5.1
- 250S			51	288	236					10,000	5.9
MSL20 - 150S			45	188	136					15,000	4.7
- 200S	20	30	50	238	186	15	20	22	M8	12,000	5.3
- 250S			55	288	236					10,000	6.0
MSL25 - 150S			50	188	136					15,000	4.8
- 200S	25	35	55	238	186	15	20	22	M10	12,000	5.4
- 250S			60	288	236					10,000	6.2
MSL32 - 150S			55	188	136					15,000	5.0
- 200S	32	42	60	238	186	15	20	22	M10	12,000	5.6
- 250S			65	288	236					10,000	6.4

- ▶ MSL홀더 볼트는 SELUX 전용 볼트를 사용하시기 바랍니다.
- ▶ Please only use SELUX private bolt for MSL HOLDER.
- ▶ 육각렌치는 별도 판매입니다.
- ▶ Wrench is ordered separately.
- ▶ S Type는 표준길이(+38mm)
- ▶ S type is extended by 38mm compare to standard type.

MSL BOLT

Item	Size	Length/pcs	chuck
MSL3 - BS	M3*0.5P	4mm / 2pcs.	MSL3
MSL4 - BS	M4*0.5P	4mm / 2pcs.	MSL4
MSL6 - BS	M6*0.75P	5, 6mm / 1pcs. Each	MSL6
MSL8 - BS		5, 6mm / 1pcs. Each	MSL8
MSL10 - BS	M8*0.75P	7mm / 1pcs. 8mm / 1pcs. 9mm / pcs.	MSL10
MSL12 - BS		7mm / 1pcs. 8mm / 1pcs. 9mm / pcs.	MSL12
MSL16 - BS		7mm / 1pcs. 8mm / 1pcs. 9mm / pcs.	MSL16
MSL20 - BS	M10*10P	7mm / 1pcs. 8mm / 1pcs. 9mm / pcs.	MSL20
MSL25 - BS		7mm / 1pcs. 8mm / 1pcs. 9mm / pcs.	MSL25
MSL32 - BS		6mm / 1pcs. 7mm / 1pcs. 8mm / pcs.	MSL32

JACOBS TAPER ARBOR

CODE No.

BT50 JTA6 45

Shank Jacobs No. Length

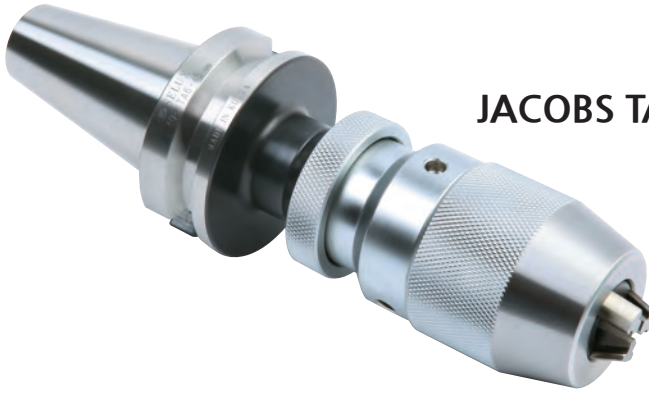

JACOBS TAPER 접촉을 80% 이상 진동없음.

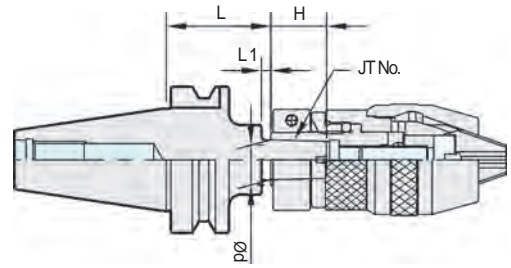

PRODUCT INFORMATION

■ Drill chuck은 포함되어 있지 않습니다. ■ Drill chuck is not included.

Code No.	ød	JT No.	L	L1	H	Weight (kg)
BT30 - JTA2 - 30	14.199	2	30	4	20	1.0
JTA6 - 30	17.170	6			24	1.0
BT40 - JTA2 - 45	14.199	2	45	4	20	1.1
- 90			90			1.4
JTA6 - 45	17.170	6	45		24	1.1
- 90			90			1.4
BT50 - JTA2 - 45	14.199	2	45	4	20	4.0
- 105			105			4.4
JTA6 - 45	17.170	6	45		24	4.0
- 105			105			4.4

MORSE TAPER HOLDER

■for Morse taper shank with tang.

CODE No.

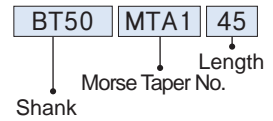

TAPER 접촉을 80% 이상 진동없음.

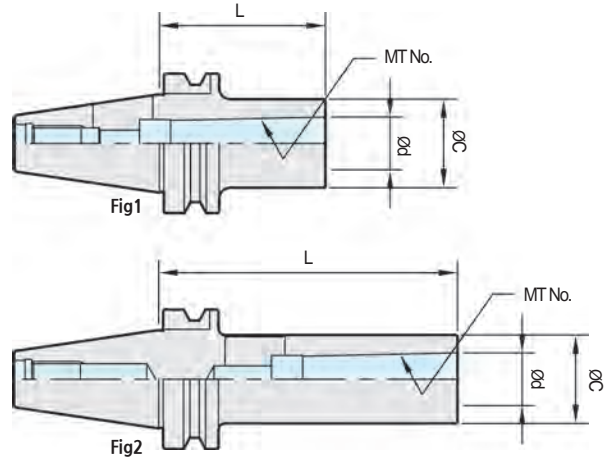

PRODUCT INFORMATION

■ Drill, reamer, 기타(MT Shank type tool)등을 사용 할 수 있습니다. ■ MORSE TAPER HOLDER can use tool holder for drill, reamer, etc.

Code No.	ød	MT No.	L	øC	Fig	Weight (kg)
BT30 - MTA1 - 45	12.065	1	45	25	1	0.5
MTA2 - 60	17.780	2	60	32		0.5
MTA3 - 80	23.825	3	80	40		0.5
BT40 - MTA1 - 45	12.065	1	45	25	1	1.0
- 120			120		2	1.3
MTA2 - 60	17.780	2	60	32	1	1.0
- 120			120		2	1.5
MTA3 - 75	23.825	3	75	40	1	1.0
- 135			135		2	1.7
MTA4 - 95	31.267	4	95	50	1	1.6
- 165			165		2	1.7
BT50 - MTA1 - 45	12.065	1	45	25	1	3.9
- 120			120		2	4.2
- 180			180			4.3
MTA2 - 45	17.780	2	45	32	1	3.9
- 135			135		2	4.3
- 180			180			4.6
MTA3 - 45	23.825	3	45	40	1	3.8
- 150			150		2	4.6
- 180			180			4.9
MTA4 - 75	31.267	4	75	50	1	3.9
- 180			180		2	5.4
MTA5 - 105	44.399	5	105	65	1	4.5
- 210			210		2	7.2

Drill Dia and Shank

Shank		MT1	MT2	MT3	MT4	MT5
Drill dia	Min	3.0	14.5	23.5	32.0	51.0
	Max	14.0	23.0	31.5	50.0	76.0

MORSE TAPER HOLDER

for Morse taper shank with tang.

CODE No.

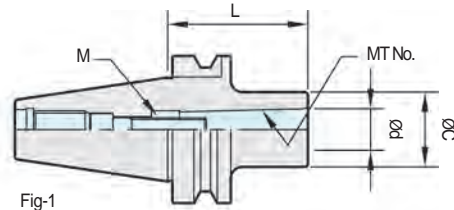
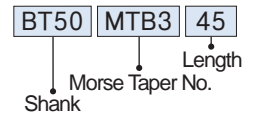

Draw BOLT Type

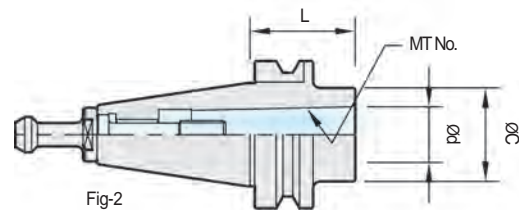

Pull - Stud Draw BOLT Type()

PRODUCT INFORMATION

- Fig 1의 경우 Draw Bolt가 포함되어 있습니다. Draw-in Bolt is supplied with Fig 1 type arbor.
- Fig 2의 경우 전용 pull stud bolt가 필요합니다. for Fig2, it is necessary for special pull stud bolt as exclusive use.

Code No.	ød	MT No.	L	øC	M	Fig	Weight (kg)
BT30 - MTB1 - 45	12.065	1	45	25	M 6	1	0.8
MTB2 - 60	17.780	2	60	32	M10	2	0.8
MTB3 - 80	23.825	3	80	40	M12		1.0
BT40 - MTB1 - 45	12.065	1	45	25	M 6	1	1.0
MTB2 - 45	17.780	2	45	32	M10		1.1
MTB3 - 45	23.825	3	45	40	M12	2	1.1
MTB4 - 85	31.267	4	85	50	M16		1.3
BT50 - MTB1 - 45	12.065	1	45	25	M 6	1	3.9
MTB2 - 45	17.780	2	45	32	M10		3.9
MTB3 - 60	23.825	3	60	40	M12		3.9
MTB4 - 70	31.267	4	70	50	M16		3.9
MTB5 - 105	44.399	5	105	65	M20	2	4.0

SPECIAL PULL STUD BOLT

PRODUCT INFORMATION

- 전용 pull stud bolt 의 경우 주문제작 합니다. Special pull stud bolt can be ordered.

PSB Code No.	MTB2	MTB3	MTB4	MTB5
BT30 - MPS - 16	MPS - 16-2	MPS - 16-3		
- 17	MPS - 17-2	MPS - 17-3		
BT40 - MPS - 1		MPS - 1-3	MPS - 1-4	
- 2		MPS - 2-3	MPS - 2-4	
- 806		MPS - 806-3	MPS - 806-4	
- G51		MPS - G51-3	MPS - G51-3	
BT50 - MPS - 5				MPS - 5-5
- 6				MPS - 6-5
- 0				MPS - 0-5

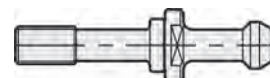

MT No.	MT No.
1	M 6 x 1.0
2	M10 x 1.5
3	M12 x 1.75
4	M16 x 2.0
5	M20 x 2.5

FACE MILL ARBOR

CODE No.

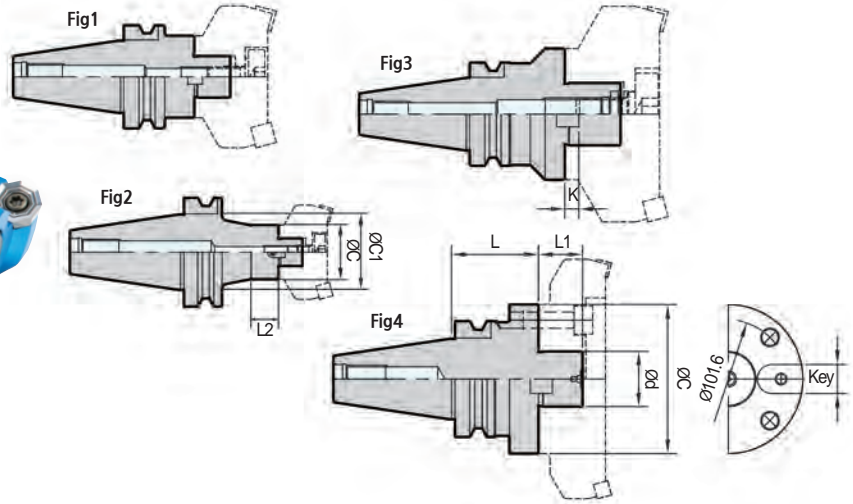
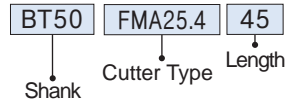

BT SHANK
FACE MILL ARBOR

PRODUCT INFORMATION

■ JIS B4113 face milling용입니다. ■ For face-milling cutter conforming to JIS B4113.

Code No.	ød	Cutter Dia	L	øC	C1	L1	L2	Key	K	Fig	Weight (kg)	
BT30 - FMA25.4 - 45	25.4	80	45	50		22		K9.5 - S	5	3	0.8	
FMA31.75 - 45	31.75	100		60		30		K12.7 - S	7		1.0	
BT40 - FMA25.4 - 45	25.4	80	45	50	-	22	-	K9.5 - S	5	1	1.4	
- 90			90					K9.5 - L			7	3.0
FMA31.75 - 45	31.75	100	45	60		30		K12.7 - S	7		2.0	
- 75			75					K12.7 - S			7	3.2
FMA38.1 - 60	38.1	125	60	80		34		K15.85 - S	9	3	3.8	
BT50 - FMA25.4 - 45	25.4	80	45	50		22	25	K9.5 - S	5	1	3.8	
- 90			90					K9.5 - L			7	4.5
- 150			150					70		2	5.5	
FMA31.75 - 45	31.75	100	45	60	-	30	-	K12.7 - S	7	1	4.6	
- 75			75					K12.7 - L			7	5.2
- 105			105					2		5.5		
- 150			150							7.0		
FMA38.1 - 45	38.1	125	45	80	-	34	-	K15.85 - S	9	1	4.3	
- 75			75					K15.85 - L			9	5.0
- 105			105					5.5				
- 150			150					8.5				
FMA50.8 - 45	50.8	160	45	100	-	36	-	K19 - S	10		4.8	
- 75			75					K19 - S			10	6.8
- 105			105					7.8				
FMA47.625 - 75	47.625	200	75	128.5		38		K25.4	12.5	4	7.6	

▶ 페이스밀아바 스페어 파트는 P75

▶ The spare parts for FACE MILL ARBOR are refered. P75

LONG TYPE FACE MILL ARBOR

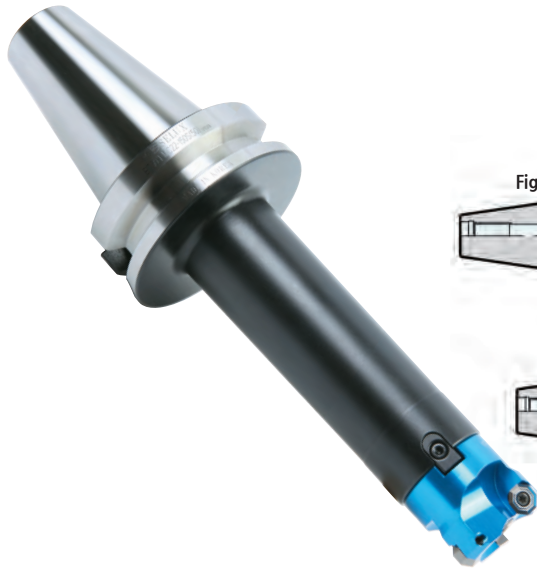

CODE No.

BT50 FMA31.75 200 S

Shank Cutter Type Length Gage line not included

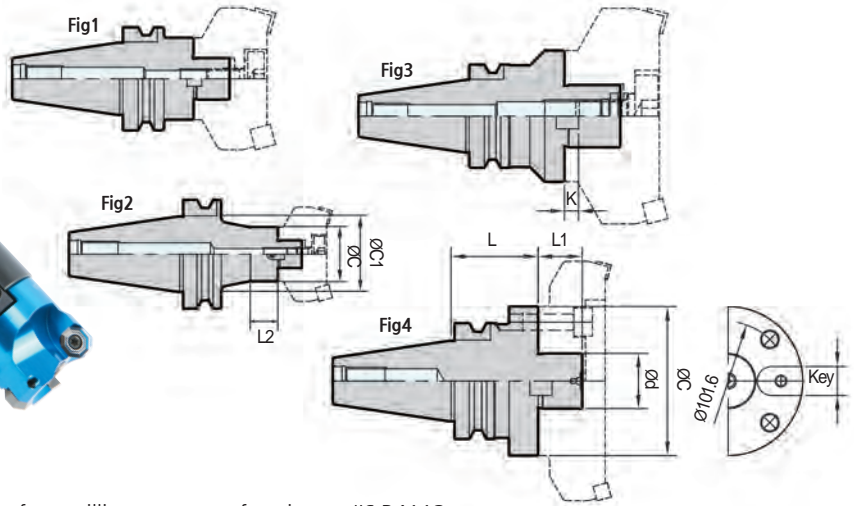

PRODUCT INFORMATION

■ JIS B4113 face milling용입니다.
■ (S)Type은 표준길이(+38mm)

■ For face-milling cutter conforming to JIS B4113.
■ S type is extended by 38mm compare to standard type.

Code No.	ød	Cutter Dia	L	øC	C1	L1	L2	Key	K	Fig	Weight (kg)
BT50-FMA25.4 - 200	25.4	80	200	50	70	22	25	K9.5-L	5	2	8.7
			250		74						10.3
			300		75						11.8
			350		79						13.5
			400		79						15.8
BT50-FMA31.75 - 200	31.75	100	200	60	70	30	25	K12.7-L	7	2	9.7
			250								11.6
			300								13.4
			350								15.7
			400								18.4
			- 150S	188	-	-	-	-	1	9.4	
			- 200S	238	-	-	-	-	10.8		
			- 250S	288	79	30	25	K12.7-L	7	2	13.0
			- 300S	338	80	30	25	K12.7-L	7	2	15.3
			- 350S	388	80	30	25	K12.7-L	7	2	18.5
- 400S	438	80	30	25	K12.7-L	7	2	21.5			
BT50-FMA38.1 - 200	38.1	125	200	80	-	34	-	K15.85-L	9	1	14.5
			250								17.5
			300								20.5
			350								23.5
			400								26.6
BT50-FMA50.8 - 150	50.8	160	150	100	-	36	-	K19-L	10	1	8.7
			200								11.5
			250								14.5
			300								18.5
			350								25.5
			400								28.9
BT50-FMA47.625 - 105	47.625	200	105	128.5	-	38	-	K25.4	12.5	4	8.9
			150								12.5
			200								15.8
			250								20.5
			300								26.5

▶ 페이스밀아바 스페어 파츠는 P75

▶ The spare parts for FACE MILL ARBOR are referred. P75

FACE MILL ARBOR

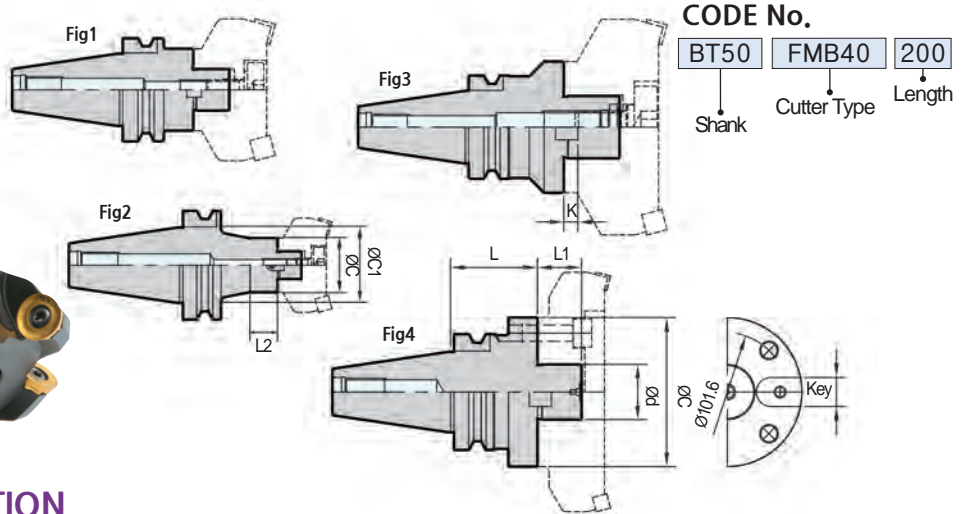
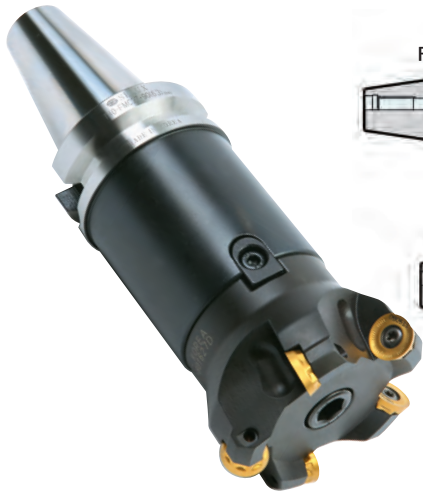

PRODUCT INFORMATION

- JIS B4113 face milling용 입니다.
- (S)Type은 표준길이(+38mm)

- For face-milling cutter conforming to JIS B4113.
- S type is extended by 38mm compare to standard type.

Code No.	ød	Cutter Dia	L	øC	L1	Key	K	Fig	Weight (kg)
BT30-FMB25.4 - 45	25.4	80	45	80	26	K9.5-S	5	3	1.5
BT30-FMB27 - 45	27		45			K12-S	6		1.8
BT40-FMB25.4 - 60	25.4	80	60	80	26	K9.5-L	5	3	3.6
- 90			90						4.8
BT40-FMB38.1 - 60	38.1	100	60	85	26	K15.85-S	9	3	3.6
BT40-FMB27 - 60	27	80	60	80		K12-L	6		3.6
- 90			90	80	4.8				
BT40-FMB40 - 60	40	100	60	85	26	K15.85-S	8.5	1	3.8
BT50-FMB25.4 - 45	25.4	80	45	80		26	K9.5-L	5	1
- 90			90		5.8				
-150			150		8.0				
BT50-FMB38.1 - 45	38.1	100	45	85	26	K15.85-S	9	4	4.6
- 75			75			6.0			
-105			105			8.8			
BT50-FMB38.1F - 75	38.1	160	75	110	26	K12-S	6	4	5.0
BT50-FMB27 - 45	27	80	45	80		K12-L			6
- 90			90	80	5.8				
-150			150	80	9.2				
BT50-FMB40 - 45	40	100	45	85	26	K15.85-S	8.5	1	4.6
- 75			75						6.0
-105			105						8.7
-150			150						11.5
-200			200						14.5
-250			250						17.5
-300			300						20.5
-350			350						23.6
-400			400						27.5
BT50-FMB40F - 75			160						160
-105	105	8.9							
-150	150	11.8							
-200	200	14.9							
-250	250	18.2							
BT50-FMB60 - 75	60	200	75	140	25	K25.4	12.5	4	7.9
-105			105						9.8
-150			150						12.5
-200			200						15.8
-250			250						20.0

▶ 페이스밀아바 스페어 파트는 P75

▶ The spare parts for FACE MILL ARBOR are referred. P75

FACE MILL ARBOR

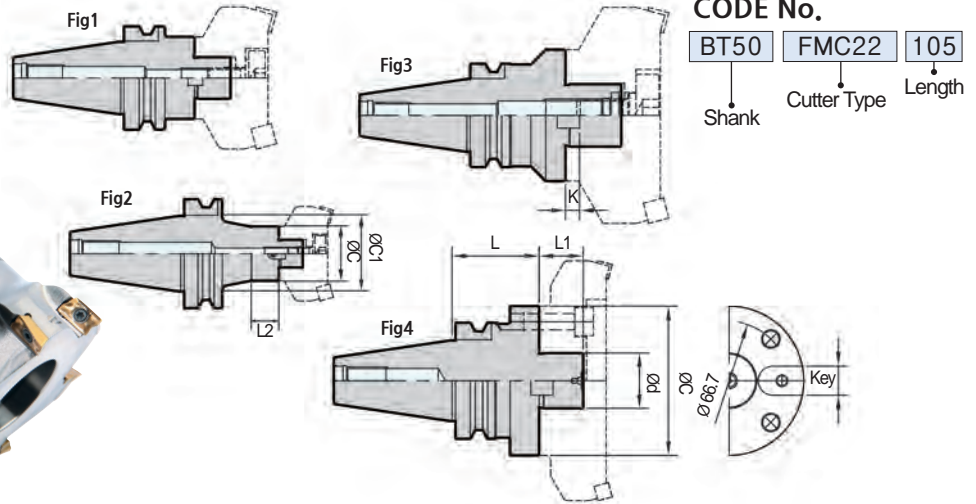
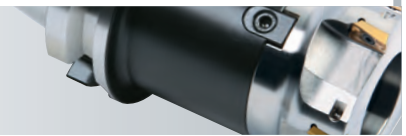

CODE No.
 BT50 | FMC22 | 105
 Shank | Cutter Type | Length

PRODUCT INFORMATION

■ JIS B4113 face milling용입니다.
 ■ (S)Type은 표준길이(+38mm)

■ For face-milling cutter conforming to JIS B4113.
 ■ S type is extended by 38mm compare to standard type.

Code No.	ød	Cutter Dia	L	øC	øC1	L1	L2	Key	K	Fig	Weight (kg)			
BT30 - FMC16 - 45	16	40	45	38	-	16	-	K8-S	5	1	1.2			
FMC22 - 45	22	50/63	90	45	-	18	-	K10-S	5.5		1.5			
- 90											1.5			
FMC27 - 45	27	63/80	45	60	-	20	-	K12-S	6	3	1.5			
FMC32 - 45	32	100		80	-	22	-	K14-S	7		2.0			
BT40 - FMC16 - 45	16	40	45	38	-	16	-	K8-S	5	1	1.7			
FMC22 - 45	22	50/63	90	45	-	18	-	K10-S	5.5		2.0			
- 90								K10-L			2.2			
FMC25.4 - 60	25.4	63/80	60	70	-	20	-	K9.5-S	6	3	2.5			
- 90	90													2.7
FMC27 - 60	27		60	60	-							K12-S		2.5
- 90			90					K12-L		3.4				
FMC32 - 60	32	100	60	80	-	22	-	K14-S	7	3	3.4			
- 90	90											K14-L		3.8
FMC38.1 - 60	38.1		60	85	-							K15.85-S		4.7
- 90			90					K15.85-L		5.0				
FMC40 - 60	40	125/160	60	90	-	26	-	K15.85-S	8	4	5.2			
BT50 - FMC16 - 60	16	40	60	38	-	16	-	K8-S	5.0	1	3.2			
FMC22 - 60								K10-S			3.6			
- 105	22	50/63	105	45	-	18	-	K10-L	5.5		5.5			
- 150(50)					48	25	-	K10-L		2	7.3			
- 150(63)			150	58	63									7.3
FMC25.4 - 45	25.4	63/80	45	70	-	20	-	K9.5-S	6	1	4.1			
- 90	90											K9.5-L		6.0
- 150				150										7.9
FMC27 - 45	27	63/80	45	60	-	20	-	K12-S	6	1	5.0			
- 90	90											K12-L		6.0
- 150(63)				150	68									7.5
- 150(80)										7.5				
FMC32 - 45	32	100	45	80	-	22	-	K14-S	7	1	5.0			
- 75	75											K14-L		6.0
- 105				105										6.8
- 150			150							9.8				
FMC38.1 - 45	38.1	100	45	85	-	22	-	K15.85-S	7	1	5.8			
- 75	75											K15.85-L		6.0
- 105				105										7.0
FMC40 - 45	40	125/160	45	90	-	26	-	K15.85-S	8	4	6.2			
- 75			75					K15.85-L			6.8			

▶ 페이스밀아바 스페어 파트는 P75

▶ The spare parts for FACE MILL ARBOR are referred. P75

LONG TYPE FACE MILL ARBOR



CODE No.

BT50	FMC22	200	S
Shank	Cutter Type	Length	Gage line not included

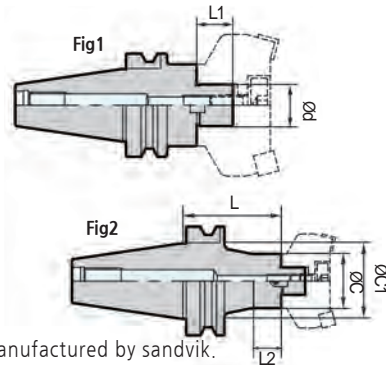

PRODUCT INFORMATION

- Sandvik T-MAX face mill cutter 전용 arbor 입니다. ■ Only For T-MAX face mill cutter arbor manufactured by sandvik.
- (S)Type표준길(+38mm) ■ S type is extended by 38mm compare to standard type.
- 주문시 체결될 Cutter의 Size를 확인 ■ Please check the cutter about the size when ordering.

Code No.	ød	Cutter Dia	L	øC	C1	L1	L2	Key	K	Fig	Weight (kg)						
BT50-FMC22- 100S(ø50)	22	50	138	47	50	18	25	K10-L	5.5	2	8.0						
- 150S(ø50)			188								8.7						
- 200S(ø50)			238								10.3						
- 250S(ø50)			288								11.8						
- 300S(ø50)			338								13.5						
- 350S(ø50)			388								15.8						
- 400S(ø50)			438								18.2						
- 100S(ø63)			138								8.2						
- 150S(ø63)		188	8.7														
- 200S(ø63)		238	10.3														
- 250S(ø63)		288	11.8														
- 300S(ø63)		338	13.5														
- 350S(ø63)		388	15.8														
- 400S(ø63)		438	185.2														
BT50-FMC25.4 - 150S(ø63)		25.4	63	188	58						62	20	25	K9.5-L	6	2	8.7
- 200S(ø63)				238													10.3
- 250S(ø63)	288			11.8													
- 300S(ø63)	338			13.5													
- 350S(ø63)	388			15.8													
- 400S(ø63)	438			18.2													
- 150S(ø80)	188			8.7													
- 200S(ø80)	238			10.3													
- 250S(ø80)	288		11.8														
- 300S(ø80)	338		13.5														
- 350S(ø80)	388		15.8														
- 400S(ø80)	438		18.2														
- 150S(ø80)	188		8.7														
- 200S(ø80)	238		10.3														
- 250S(ø80)	288		11.8														
- 300S(ø80)	338		13.5														
- 350S(ø80)	388	15.8															
- 400S(ø80)	438	18.2															
BT50-FMC27 - 150S(ø63)	27	63	188	58	62	20	25	K12-L	6	2	8.7						
- 200S(ø63)			238								10.3						
- 250S(ø63)			288								11.8						
- 300S(ø63)			338								13.5						
- 350S(ø63)			388								15.8						
- 400S(ø63)			438								18.2						
- 150S(ø80)			188								9.0						
- 200S(ø80)			238								11.5						
- 250S(ø80)		288	13.5														
- 300S(ø80)		338	16.0														
- 350S(ø80)		388	19.0														
- 400S(ø80)		438	20.0														
- 150S(ø80)		188	9.4														
- 200S(ø80)		238	10.8														
- 250S(ø80)		288	13.0														
- 300S(ø80)		338	15.3														
- 350S(ø80)	388	18.5															
- 400S(ø80)	438	21.5															
BT50-FMC32 -150S	32	80	188	75	79	22	25	K14-L	7	1	9.4						
-200S			238								10.8						
-250S			288								13.0						
-300S			338								15.3						
-350S			388								18.5						
-400S			438								21.5						

▶ 페이스밀아바 스페어 파트는 P75

▶ The spare parts for FACE MILL ARBOR are referred. P75

FACE MILL ARBOR (COOLANT TYPE)

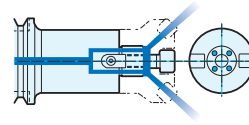

CODE No.

BT50 FMH22 105
 Shank Cutter Type Length

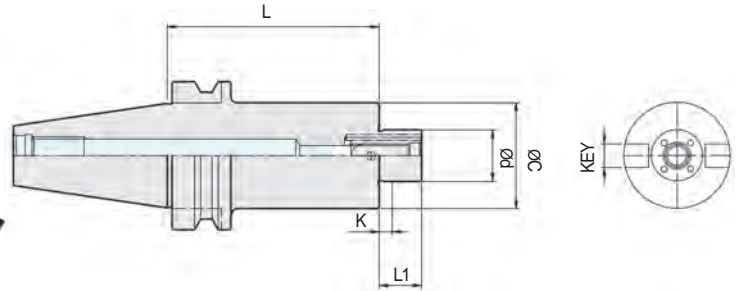

PRODUCT INFORMATION



- 쿨런트 컷터 전용
- Only use coolant cutter.
- 컷터 가공성 향상 공구사용시간 증가
- Improve tool life and cutting operation

Code No.	ød	øC	L	L1	K	KEY	Weight (kg)
BT30 - FMH16 - 45	16	38	45	16	5	K8-S	1.2
FMH22 - 45	22	45		18	5.5	K10-S	1.5
- 90			90	6	K12-S	1.5	
FMH27 - 45	27	60	45	20	6	K12-S	1.5
BT40 - FMH16 - 45	16	38	45	16	5	K8-S	1.7
FMH22 - 45	22	45		18	5.5	K10-S	2.3
- 90			90	6	K10-L	2.2	
FMH27 - 60	27	60	60	20	6	K12-S	2.5
- 90			90			K12-L	3.4
FMH32 - 60	32	80	60	22	7	K14-S	3.4
FMH25.4 - 60						25.4	70
- 90	90	2.7					
FMH31.75 - 60	31.75	76	60	30	7	K12.7-S	2.7
- 90			90			3.2	
FMH38.1 - 60	38.1	85	60	34	9	K15.85-S	4.7
- 90			90			K15.85-L	5.0
BT50 - FMH22 - 60	22	45	60	18	5.5	K10-S	3.6
- 105			105			K10-L	5.5
- 150			150			7.3	
FMH27 - 90	27	60	90	20	6	K12-L	6.0
- 150			150				7.5
FMH32 - 90	32	80	90	22	7	K14-L	6.5
- 150			150				8.0
FMH25.4 - 90	25.4	70	90	20	6	K9.5-L	6.0
- 150			150				7.9
FMH31.75 - 90	31.75	76	90	30	7	K12.7-L	6.2
- 150			150				8.5
FMH38.1 - 90	38.1	85	90	34	9	K15.85-L	7.0
- 150			150				9.0

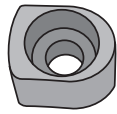
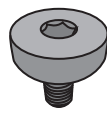

▶ FMH 클램프볼트 및 부품은 일반 FMA, FMC 아바와 호환합니다. ▶ FMH clamp bolt and other parts is compatible with FACE MILL ARBOR FMA, FMC.
 ▶ 페이스밀아바 스페어 파트는 P75 ▶ The spare parts for FACE MILL ARBOR are referred. P75

FACE MILL ARBOR SPARE PARTS

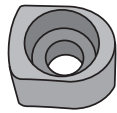
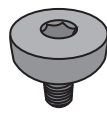

FMA Type

Type	Spare Parts			
	Basic			
	Key	Clamp Bolt	Key Bolt	Wrench Bolt
				
FMA25.4	K9.5	MBA-M12	BX0412	BX1230(Option)
FMA31.75	K12.7	MBA-M16	BX0515	-
FMA38.1	K15.85	MBA-M20	BX0615	-
FMA50.8	K19	MBA-M24	BX0820	-
FMA47.625	K25.4	-	BX1020	BX1645

FMB Type

Type	Spare Parts			
	Basic			
	Key	Clamp Bolt	Key Bolt	Wrench Bolt
				
FMB25.4	K9.5	MBA-M12	BX0412	BX1230(Option)
FMB38.1	K15.85	MBA-M20	BX0615	-
FMB38.1F		-		
FMB27	K12.0	MBA-M12	BX0515	BX1230(Option)
FMB40	K15.85	MBA-M20	BX0615	-
FMB40F	K15.85		BX1230	
FMB60	K25.4	-	BX1020	BX1645

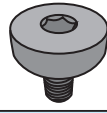
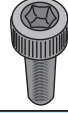
FMC Type

Type	Spare Parts			
	Basic			
	Key	Clamp Bolt	Key Bolt	Wrench Bolt
				
FMC16	K8	-	BX0310	BX0820
FMC22	K10	-	BX0412	BX1025
FMC25.4	K9.5	MBA-M12	BX0412	BX1230(Option)
FMC27	K12.0	MBA-M12	BX0515	BX1230(Option)
FMC32	K14.0	MBA-M16	BX0615	BX1645(Option)
FMC38.1	K15.85	MBA-M16	BX0615	BX1645(Option)
FMC40	K15.85	MBA-M20	BX0615	BX1230(Option)

▶ 스페어 파트 주문시에는 반드시 품명의 정확한 확인이 필요합니다.

▶ Key 주문시에는 제품상세표에서 LONG/SHORT Key를 확인해주시시오.

▶ Please pay attention to check spare parts list when you order.

▶ Please check long/short key when you order.

PRO MILL ARBOR



CODE No.

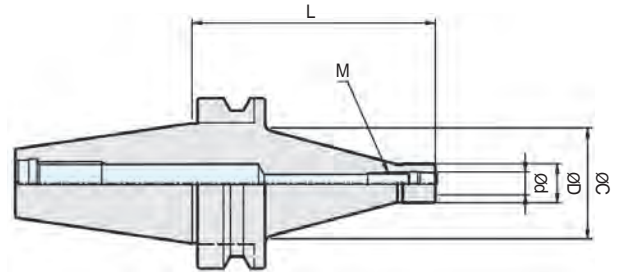
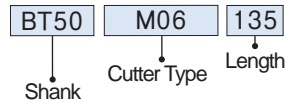

PRODUCT INFORMATION

- 모듈라 방식으로 원가 절감
- 높은 정밀도
- 이면구속 체결로 흔들림 감소
- 헤드 교체로 다양한 작업가능
- Cost reduction effect with modular system.
- Excellent accuracy.
- Vibration damping effect due to dual face contact.
- A various operation with exchanging head.

Code No.	ød	L	øD	øC	M	Weight (kg)	
BT40 - M06 - 90	6.5	90	10	40	M6	1.2	
- 120		120				1.5	
M08 - 90	8.5	90	14.4		M8	1.2	
- 120		120				1.5	
M10 - 90	10.5	90	18		M10	1.3	
- 120		120				1.5	
- 150		150				1.9	
M12 - 120	12.5	120	22.5		M12	1.5	
- 150		150				1.9	
- 165		165				2.2	
BT50 - M06 - 135	6.5	135	10		65	M6	4.2
- 165		165					4.9
M08 - 135	8.5	135	14.4	M8		4.2	
- 165		165				4.9	
M10 - 135	10.5	135	18	M10		4.2	
- 165		165				4.9	
- 165		165				4.9	
M12 - 135	12.5	135	22.5	M12		4.2	
- 165		165				4.9	

PRO MILL CUTTER(Ball Type)

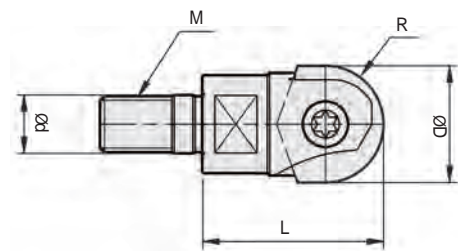

PRODUCT INFORMATION

- HITACHI 인서트 호환
- 경삭 R작업 최적화
- Compatible with HITACHI insert.
- Optimal for R-finishing operation.

Code No.	R	øD	L	ød	M	Insert	Screw	Wrench
R05M0630	5	10	30	6.5	M6	ZPFG100, ZCFW100	TNS-5842	TXL-10
R06M0630	6	12				ZPFG120, ZCFW120	TNS-5843	TXT-20
R08M0830	8	16	35	10.5	M10	ZPFG160, ZCFW160	TNS-5844	
R10M1035	10	20				ZPFG200, ZCFW200	TNS-5845	
R12M1240	12.5	25	40	12.5	M12	ZPFG250, ZCFW250	TNS-5846	TXT-30

▶ 다양한 Type의 컷터 제작가능합니다.
▶ 전용 스패너는 별매입니다.

▶ Cutters can be made of a variety of Type.
▶ Spanner is orderd seperately.

SIDE CUTTER ARBOR



CODE No.

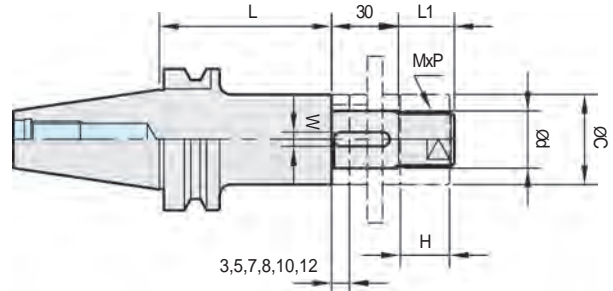

BT50 SCA25.4 90
 Shank Cutter Type Length



PRODUCT INFORMATION

- JIS B4219,4109,4107 side cutter type 입니다. ■ For side cutters conforming to JIS B4219, 4019, and 4107.
- Key, collar 및 nut는 부착되어 있습니다. ■ Key, collar and nut attached.

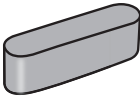
Code No.	ød	L	øC	L1	W	H	M x P	Weight (kg)
BT30 - SCA25.4 - 60	25.4	60	40	25	6.35	21	M24X1.5	0.9
BT40 - SCA25.4 - 75	25.4	75	40	25	6.35	21	M24X1.5	2.1
		120						2.5
SCA31.75 - 90	31.75	90	46	30	7.93	26	M30X1.5	2.6
		120						2.9
BT50 - SCA25.4 - 90	25.4	90	40	25	6.35	21	M24X1.5	4.7
		135						5.0
SCA31.75 - 90	31.75	90	46	30	7.93	26	M30X1.5	5.1
		135						5.7
SCA38.1 - 90	38.1	90	55	36	9.53	31	M36X1.5	5.8
		135						6.8

Spare Parts			
Type	Parallel Key	Collar	Lock Nut
SCA25.4			
SCA31.75	6.35 x 6.35 x 25	SCA25.4 -Set	SCA-M24
SCA38.1	7.92 x 7 x 25	SCA31.75 -Set	SCA-M30
	9.52 x 8 x 25	SCA38.1 -Set	SCA-M36

CUTTER HOLDER

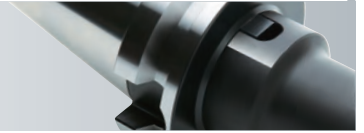

CODE No.

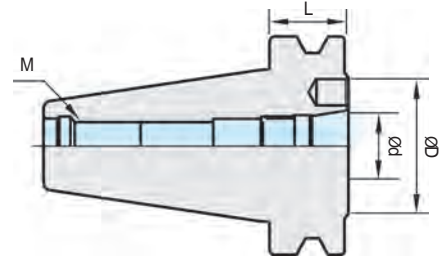
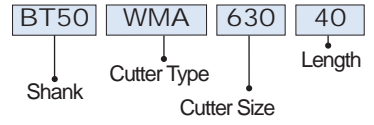

BT SHANK CUTTER HOLDER

PRODUCT INFORMATION

■ FPC 컷터, 볼컷터 전용 홀더

■ FPC, ball cutter holder.

Code No.	øD	ød	L	M	Weight (kg)
BT50 - WMA - 63040	63	31.75	40	M24	3.2
BT50 - WMA - 80040	80	44.45	40		3.2

SQUARE BORING BAR

Boring Range $\varnothing 25.0 - \varnothing 190.0$ 

CODE No.

BT50	BSA50	180
Shank	45°	Length

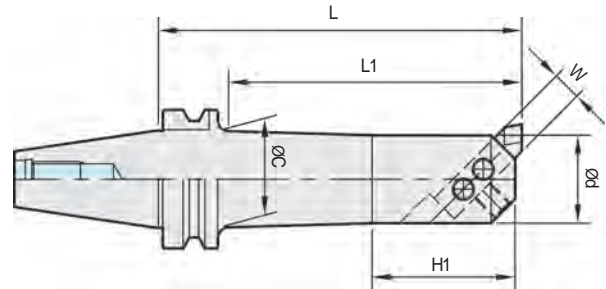

PRODUCT INFORMATION

- 황삭용 Boring 및 중간정삭 Boring. ■ Rough boring and semi finish boring.
- 막힌 구멍과 관통된 구멍 Boring. ■ Both blind and through hole boring.

Code No.	ød	Boring Range		L	øC	L1	H1	W	Weight (kg)
		min	max						
BT30 - BSA25 - 120	20	25	38	120	22	92	35	8	0.5
BSA30 - 150	24	30	42	150	26	121	40		0.9
BSA38 - 165	30	38	52	165	33	135	50	10	0.9
BSA42 - 165	34	42	56		37	138	60		0.9
BT40 - BSA25 - 135	20	25	38	165	22	105	35	8	1.2
BSA30 - 165	24	30	42		26		40		1.3
BSA38 - 165	30	38	52		33	50	1.8		
BSA42 - 165	34	42	56		37	133	60	1.9	
BSA50 - 165	40	50	65	210	44	178	65	13	2.2
- 210									2.6
BSA62 - 165	50	62	90	165	50	133	80	16	3.3
- 225				225	56	193			3.6
BSA72 - 165	60	72	110	165	60	-	95	19	3.6
- 225				225					4.5
BSA90 - 165	75	90	125	165	62	-	60	19	4.2
- 210				210					6.5
BT50 - BSA25 - 135	20	25	38	135	22	92	35	8	4.0
BSA30 - 165	24	30	42	165	26	122	40		4.2
BSA38 - 180	30	38	52	180	33	137	50	10	4.5
BSA42 - 210	34	42	56	210	37	167	60		4.6
BSA50 - 180	40	50	65	180	46	137	65	13	5.0
- 240				240		197			5.4
BSA62 - 195	50	62	90	195	56	152	80	16	6.5
- 270				270		227			7.0
BSA72 - 195	60	60	110	195	66	152	95	19	7.0
- 285				285		242			7.5
BSA90 - 210	75	72	125	210	80	167	110	19	8.5
- 300				300		257			9.4
BSA105 - 195	90	105	160	195	90	-	130	25	11.0
- 285				285					94
BSA130 - 255	110	130	190	255	99	-	85	25	15.0

▶ 보링바이트는 별도 구매입니다.

▶ BORING BITE is ordered separately.

SQUARE BORING BAR

Boring Range $\varnothing 25.0 - \varnothing 260.0$

CODE No.

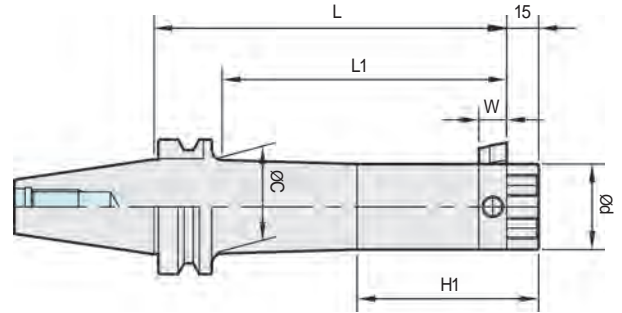
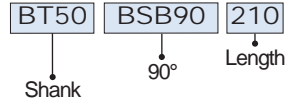

PRODUCT INFORMATION

- 황삭용 Boring 및 중간정삭 Boring. ■ Rough boring and semi finish boring.
- 막힌 구멍과 관통된 구멍 Boring. ■ Both blind and through hole boring.

Code No.	ød	Boring Range		L	øC	L1	H1	W	Weight (kg)
		min	max						
BT30 - BSB25 - 120	20	25	52	120	22	92	50	8	1.2
BSB38 - 165	30	38	70	165	33	121	70	10	1.2
BSB50 - 165	40	50	90		44	135	85	13	1.2
BT40 - BSB25 - 135	20	25	52	135	22	90	50	8	1.4
BSB38 - 165	30	38	70	165	33	135	70	10	1.5
BSB50 - 165	40	50	90		44		180	85	13
- 210									
BSB62 - 165	50	62	115	165	-	135	95	16	3.2
- 225				225	56	180			3.4
BSB72 - 165	60	72	135	165	-	135	10	19	3.8
- 225				225		195			4.0
BSB90 - 165	75	90	150	165	-	-	130	19	4.0
- 210				210					210
BT50 - BSB25 - 135	20	25	52	135	22	92	50	8	4.0
BSB38 - 180	30	38	70	180	33	137	70	10	4.2
BSB50 - 180	40	50	90		44		197	85	13
- 240									
BSB62 - 195	50	62	115	195	56	152	95	16	6.1
- 270				270	227	6.4			
BSB72 - 195	60	72	135	195	66	152	110	19	6.9
- 285				285		242			6.9
BSB90 - 210	75	90	150	210	80	167	130	19	8.0
- 300				300		257			8.5
BSB105 - 195	90	105	190	195	-	-	-	25	9.9
- 285				285	94	150	10.5		
BSB130 - 255	110	130	260	255	-	-	60	12.5	

▶ 보링바이트는 별도 구매입니다.

▶ BORING BITE is ordered separately.

Excellent Precision
Excellent Quality

SELUX
NC TOOLING SYSTEM

HSK

CHUCK & Item

HYDRAULIC CHUCK
MILLING CHUCK
HIGH SPEED MILLING CHUCK
SHRINK FIT HOLDER
SSK COLLET CHUCK
HIGH SPEED GSK COLLET
CHUCK
ER COLLET CHUCK
ENDMILL COLLET CHUCK
SYNCRO TAPPING CHUCK
TAPPING CHUCK HOLDER
NC DRILL CHUCK
SIDE LOCK HOLDER
MORSE TAPER HOLDER
FACE MILL ARBOR



HYDRAULIC CHUCK

Coolant-through hole
Clamping Range : $\phi 3.0 \sim \phi 32.0$

CODE No.

HSK63A SHC20 90
Shank Chucking Dia Length

MAX
25,000
min⁻¹

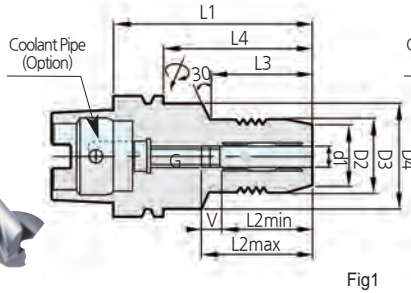

Fig1

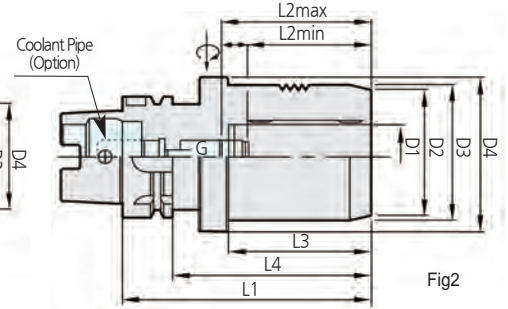

Fig2

PRODUCT INFORMATION

- 4D 선단에서 3 μ m이내의 흔들림정도
- 높은 정밀도와 고속가공에 최적화
- 유압방식의 강력한 파지력
- 렌치 하나로 쉽게 공구고정
- 3 μ m(T.I.R) Run-out at 4D away from shank nose.
- The optimal chck for excellent accuracy and high speed operation.
- Powerful clamping force of hydraulic type.
- Easy clamping with just one wrench.

CODE NO.	d1	D2	D3	D4	L1	L2max	L2min	V	L3	L4	G	Type	Weight (kg)		
HSK40A - SHC 6 - 70	6	25	28	34	70	27.5	37.5	10	28	50	M5X0.8	Fig1	0.5		
SHC 8 - 70	8	27	30		75	32.5	42.5		34	55	M6X1.0		0.5		
SHC 10 - 75	10	29	32		85	37.5	47.5		-	65	M6X1.0		0.6		
SHC 12 - 85	12	31	34										0.65		
HSK50A - SHC 6 - 70	6	25	28	40	70	27.5	37.5	10	28	44	M5X0.8	Fig1	0.65		
SHC 8 - 70	8	27	30		80	32.5	42.5		34	54	M6X1.0		0.65		
SHC 10 - 80	10	29	32		85	37.5	47.5		44	59			0.7		
SHC 12 - 85	12	31	34										0.75		
SHC 14 - 85	14	33	36	60	90	42.5	52.5	10	30	64	M6X1.0	Fig2	0.75		
SHC 16 - 90	16	35	38						30				0.9		
SHC 18 - 90	18	38	41						-				0.9		
SHC 20 - 90	20	40	42						-				1.0		
HSK63A - SHC 6 - 70	6	25	28	50	70	27.5	37.5	10	24	44	M5X0.8	Fig1	0.53		
SHC 8 - 70	8	27	30		80	32.5	42.5		35	54	M6X1.0		0.55		
SHC 10 - 80	10	29	32		85	37.5	47.5		40	59			1.08		
SHC 12 - 85	12	31	34										1.0		
SHC 14 - 85	14	33	36		90	42.5	52.5		46	64	M8X1.0		1.05		
SHC 16 - 90	16	35	38						47				1.15		
SHC 18 - 90	18	38	41						48				1.15		
SHC 20 - 90	20	40	43						48				1.2		
SHC 25 - 120	25	53	57		63	120	51		61	59	94		M16X1.0	Fig2	2.2
SHC 32 - 125	32	58	63		75	125	55		65	63	99		M16X1.0	Fig2	2.4
HSK100A - SHC 6 - 75	6	25	28	54	75	27.5	37.5	10	26	46	M5X0.8	Fig1	3.2		
SHC 8 - 75	8	27	30		90	32.5	42.5		42	61	M6X1.0		3.2		
SHC 10 - 90	10	29	32		95	37.5	47.5		47	66			3.4		
SHC 12 - 95	12	31	34										3.4		
SHC 14 - 95	14	33	36		100	42.5	52.5		53	71	M8X1.0		3.5		
SHC 16 - 100	16	35	38						59				76	4.0	
SHC 18 - 100	18	38	41						62				81	M16X1.0	4.2
SHC 20 - 105	20	40	43						110				51	61	62
SHC 25 - 110	25	53	57		63	110	51		61						4.2
SHC 32 - 110	32	58	63		75	110	55		65						

- ▶ 유압척 사용시 절삭공구 Shank공차는 h6 안에 들어오는 절삭공구 사용을 권장합니다.
- ▶ 유압척 SHC12, SHC20, SHC32는 D또는 OD콜릿을 사용하여 다양하게 공구를 척킹 할 수 있습니다.
- ▶ 유압척 전용 콜릿은 **P138~P139**
- ▶ 황삭작업에는 권장하지 않습니다.
- ▶ 내부급유 콜릿트파이프는 **P100**
- ▶ Tolerance of cutting tool shank should be configured within h6.
- ▶ HYDRAURIC CHCUK SHC12, SHC20, SHC32 are possible. to use various shank cutting tool with D or OD COLLET.
- ▶ HYDRAURIC COLLET are refered. **P138~P139**
- ▶ We do not recommend to use hydraulic chuck for roughing operation.
- ▶ The Coolant pipe are refered. **P100**

HYDRAULIC CHUCK



Coolant-through hole
Clamping Range : $\phi 3.0 \sim \phi 20.0$



CODE No.

HSK40E SHC10 75
Shank Chucking Dia Length

MAX
40,000
min⁻¹

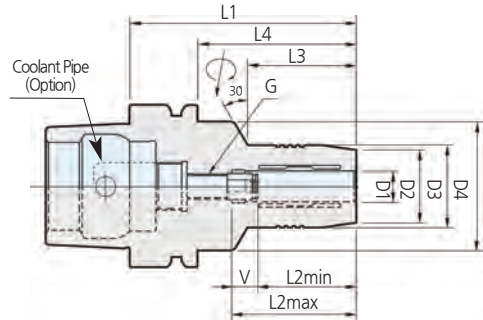

PRODUCT INFORMATION

- 4D 선단에서 3 μ m이내의 흔들림정도
- 높은 정밀도와 고속가공에 최적화
- 유압방식의 강력한 파지력
- 렌치 하나로 쉽게 공구고정
- 3 μ m(T.I.R) Run-out at 4D away from shank nose.
- The optimal chckuk for excellent accuracy and high speed operation.
- Powerful clamping force of hydraulic type.
- Easy clamping with just one wrench.

CODE NO.	D1	D2	D3	L1	L2min	L2max	V	L3	G	Weight (kg)
HSK40C - SHC 6 - 60	6	25	28	60	27.5	37.5	10	35	M5X0.8	0.6
SHC 8 - 60	8	27	30					36	M6X1.0	0.6
SHC 10 - 65	10	29	32	65	32.5	42.5		41	M6X1.0	0.6
SHC 12 - 70	12	31	34	70	37.5	47.5		47	M6X1.0	0.65
HSK50C - SHC 6 - 60	6	25	28	60	27.5	37.5	10	30	M5X0.8	0.65
SHC 8 - 60	8	27	30					35	M6X1.0	0.65
SHC 10 - 65	10	29	32	65	32.5	42.5		44	M6X1.0	0.7
SHC 12 - 75	12	31	34	75	37.5	47.5		46	M6X1.0	0.75
SHC 14 - 75	14	33	36	80	42.5	52.5	10	51	M8X1.0	0.9
SHC 16 - 80	16	35	38							0.9
SHC 18 - 80	18	38	41	20	40	43		52	M8X1.0	1.0
SHC 20 - 80	20	40	43							

CODE NO.	D1	D2	D3	D4	L1	L2min	L2max	V	L3	L4	G	Weight (kg)
HSK40E - SHC 6 - 75	6	25	28	34	75	27.5	37.5	10	28	55	M5X0.8	0.6
SHC 8 - 70	8	27	30		70					50		0.6
SHC 10 - 75	10	29	32		75	32.5	42.5		34	55	M6X1.0	0.7
SHC 12 - 85	12	31	34		85	37.5	47.5		-	65	M6X1.0	0.7
HSK50E - SHC 6 - 70	6	25	28	40.0	70	27.5	37.5	10	28	44	M5X0.8	0.7
SHC 8 - 70	8	27	30							34	54	M6X1.0
SHC 10 - 80	10	29	32		80	32.5	42.5		44	59	M6X1.0	0.8
SHC 12 - 85	12	31	34		85	37.5	42.5		30	64		0.9
SHC 16 - 90	16	35	38	60	90	42.5	52.5	10	-	64	M6X1.0	0.9
SHC 20 - 90	20	40	42	-								1.1

- ▶ 유압척 사용시 절삭공구 Shank공차는 h6 안에 들어오는 절삭공구 사용을 권장합니다.
- ▶ 유압척 SHC12, SHC20, SHC32는 D또는 OD콜릿을 사용하여 다양하게 공구를 척킹 할 수 있습니다.
- ▶ 유압척 전용 콜릿은 **P138~P139**
- ▶ 활삭작업에는 권장하지 않습니다.
- ▶ 내부급유 콜릿트파이프는 **P100**
- ▶ Tolerance of cutting tool shank should be configured within h6.
- ▶ HYDRAURIC CHCUK SHC12, SHC20, SHC32 are possible. to use various shank cutting tool with D or OD COLLET.
- ▶ HYDRAURIC COLLET are refered. **P138~P139**
- ▶ We do not recommed to use hydraulic chuck for roughing operation.
- ▶ The Coolant pipe are refered. **P100**

ID	Wrench
SHC 6~20 ϕ	4mm
SHC 25~30 ϕ	5mm

MILLING CHUCK

Coolant-through hole
Clamping Range : $\phi 3.0 \sim \phi 42.0$



CODE No.

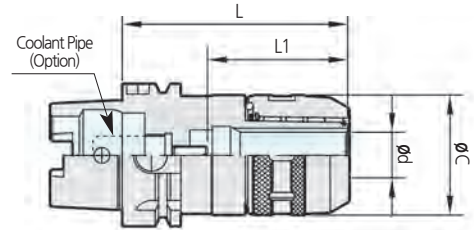

HSK63A MC32 110
Shank Chucking Dia Length



PRODUCT INFORMATION

- 높은 정밀도
- 간편한 척킹 시스템
- Taper 접촉 80% 이상 Taper공차 AT3로 보증
- 완전한 단면 밀착으로 강력 절삭
- 4배열 Roller System 방식으로 강력한 파지력
- Excellent Run-out Accuracy.
- Easy chucking system.
- More than 80% taper contact, we guarantee taper tolerance AT3.
- The strongest cutting power due to perfect face contact construction.
- Powerful clamping force by 4 needle roller system.

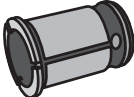
Code No.	ød	L	øC	L1	Collet	Weight (kg)
HSK40A - MC20 - 100	20	100	53	57	K20	1.2
HSK50A - MC20 - 95	20	95	53	57	K20	1.2
HSK63A - MC20 - 105	20	105	53	76	K20	1.7
MC25 - 105	25	105	62	77	K25	2.0
MC32 - 110	32	110	72	80	K32	2.2
- 130		130		100		2.6
HSK100A - MC20 - 105	20	105	53	77	K20	2.9
MC20 - 135		135				3.6
MC25 - 105	25	105	62	80	K25	3.3
- 135		135				3.6
MC32 - 115	32	120	74	81.5	K32	3.2
- 135		135		102		4.0
- 165		165		105		4.8
- 200		200		105		5.7
- 250		250		105		7.0
MC42 - 115	42	115	94	87	K42	4.8
- 135		135		112		5.5
- 165		165		120		7.0
- 200		200		120		8.5
- 250		250		120		10.8

Spare Parts		
Type	Option	
	Collet	Spanner
		
MC20	K20-NC20	MC20-SP(50-55)
MC25	K25-NC25	MC25-SP(56-61)
MC32	K32-NC32	MC32-SP(68-75)
MC42	K42-NC42	MC42-SP(88-96)

- ▶ 고속 바란스 작업시 추가 비용이 청구됩니다.
- ▶ 밀링척은 콜릿을 사용하여 다양한 Shank의 공구들을 체결할 수 있습니다.
- ▶ 밀링척 전용 콜릿은 P140~P143
- ▶ 밀링척 스패너는 별도 판매품 입니다. P157
- ▶ 내부급유 쿨런트파이프는 P100
- ▶ Extra charge for high speed balance.
- ▶ MILLING CHUCK is possible to use cutting tools of a various shank with COLLET.
- ▶ K-COLLET are referred. P140~P143
- ▶ Spanner is ordered separately. P157
- ▶ The Coolant pipe are referred. P100

HIGH SPEED MILLING CHUCK

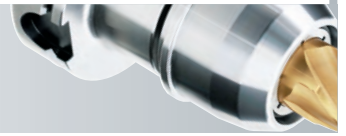

Coolant-through hole
Clamping Range : $\phi 3.0 \sim \phi 32.0$



CODE No.

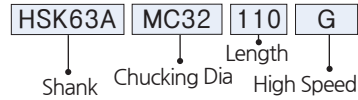

MAX
30,000
min⁻¹

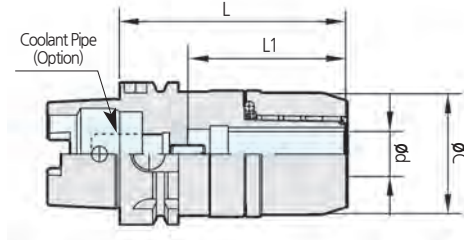

PRODUCT INFORMATION

- 고속 가공에서 높은 정도
- 강력한 파지력
- 스패너는 GH 스패너 사용(별매)
- G6.3 max 30,000RPM
- 원형너트로 고속 절삭시 소음 감소
- Excellent Run-out Accuracy.
- Powerful clamping force.
- GH spanner is orderd seperately.
- G6.3 max 25,000 RPM.
- The operation noise is reduced by assembled circle style nut.

Code No.	ϕd	L	ϕC	MAX rpm	L1	Weight (kg)
HSK40A - MC20 - 100G	20	100	48	30,000	57	1.2
HSK50A - MC20 - 95G	20	95	48	30,000	57	1.2
HSK63A - MC20 - 105G	20	105	48	25,000	76	1.7
MC25 - 105G	25		55	20,000	77	2.0
MC32 - 110G	32	110	68		80	2.2
HSK100A - MC20 - 105G	20	105	48	15,000	100	2.9
MC25 - 105G	25		55		77	3.3
MC32 - 110G	32	110	68	12,000	80	3.2
- 135G		135				4.0

Spare Parts		
Type	Option	
	Collet	Spanner
MC20-G	K20 - NC20	MC20-GH
MC25-G	K25 - NC25	MC25-GH
MC32-G	K32 - NC32	MC32-GH

- ▶ 고속밀링척은 콜릿을 사용하여 다양한 Shank의 공구들을 체결할 수 있습니다.
- ▶ 밀링척 전용 콜릿은 P140 ~ P143
- ▶ 고속밀링척 GH스패너는 별도 판매품 입니다. P157
- ▶ 내부급유 쿨런트파이프는 P100
- ▶ High speed MILLING CHUCK is possible to use cutting tools of a various shank with COLLET.
- ▶ K-COLLET is refered. P140~P143
- ▶ GH SPANNER for high speed milling chuck is orderd seperately. P157
- ▶ The Coolant pipe are refered. P100

SHRINK FIT HOLDER

Coolant-through hole

Clamping Range : $\phi 4.0 \sim \phi 12.0$



CODE No.

HSK63A SSF10 S 120
 Shank Chucking Dia Shim Length

MAX
25,000
 min⁻¹

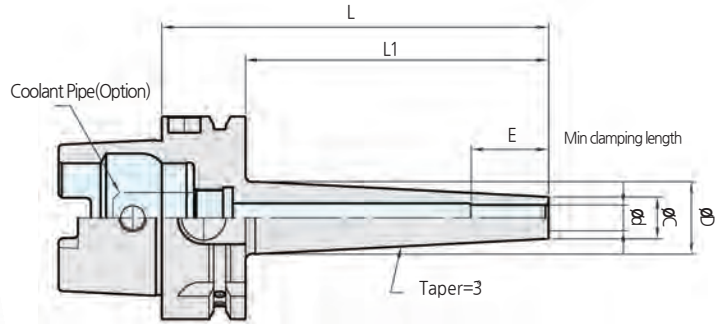

PRODUCT INFORMATION

- 4D선단에서 3 μ m이내의 흔들림 정도
- 높은 정밀도와 강력한 파지력
- 대칭적, 슬림한 디자인으로 가공최적화
- 전제품 내부급유 (Coolant Through Hole)
- 3 μ m(T.I.R) Run-out at 4D away from shank nose
- Excellent Run-out accuracy and powerful clamping
- Optimal operation with slim and symmetrical design
- All products can be used for center through coolant type

Code No.	ϕd	ϕC	ϕD	L	L1	E	Weight (kg)			
HSK40A - SSF 4S - 105	4	7	12.6	105	82	12	0.32			
						18	0.32			
						24	0.35			
						30	0.39			
						30	0.46			
HSK50A - SSF 6S - 105	6	11	18.0	105	76	18	0.62			
						24	0.65			
						30	0.68			
						30	0.71			
						30	0.71			
HSK63A - SSF 6S - 120	6	11	19.5	120	91	18	0.9			
			24.3	165	136		1.0			
			SSF 8S - 120	8	13	22.5	120	91	24	0.9
						27.2	165	136		1.1
						25.5	120	91	30	1.0
30.2	165	136	1.1							
SSF 12S - 120	12	19	28.5	120	91	30	1.0			
			33.2	165	136		1.2			

- ▶ 열박음홀더 사용시 절삭공구 Shank경은 h6의 제품을 사용해 주십시오.
- ▶ 절삭공구는 초경 Shank만 대응합니다. (하이스 제품 사용금지)
- ▶ 열박음홀더 사용시 지정된 고주파 히팅기를 사용해서 절삭공구 체결을 권장합니다.
- ▶ SELUX 고주파 히팅기는 P153
- ▶ 절삭공구 최소 삽입길이를 준수해 주시기 바랍니다.
- ▶ 공구길이조정 Stopper는 별도 판매 입니다. P153
- ▶ 내부급유 쿨런트파이프는 P100
- ▶ 열박음척 사용시 척 내경에 있는 방청유를 제거후에 사용하셔야 합니다. 내구성 저하 원인이 됩니다.

- ▶ Please use only carbide cutting tools of a shank tolerance within H6.
- ▶ Please use only carbide cutting tools for shrink fit holder. (Prohibit use HSS CUTTING TOOLS)
- ▶ We recommend shrink fit equipment when you use shrink fit holder.
- ▶ SELUX shrink fit equipment is referred. P153
- ▶ Please follow minimum insertion length of the cutting tools.
- ▶ Stopper for adjusting cutting tool length order separately. P153
- ▶ The Coolant pipe are referred. P100
- ▶ Please clean the shank outside and inside of shrink fit before use. If you don't clean the shrink fit, it has problem about Run-out and toollife.

SHRINK FIT HOLDER

Coolant-through hole
Clamping Range : $\phi 4.0 \sim \phi 20.0$

CODE No.

HSK63A SSF10 120
Shank Chucking Dia Length

MAX
25,000
min⁻¹

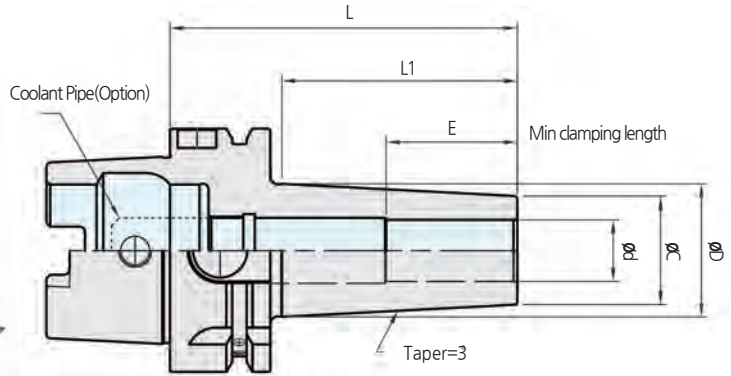

Code No.	ϕd	ϕC	ϕD	L	L1	E	Weight (kg)
HSK40A - SSF 4 - 60	4	10	14.0	60	38	12	0.27
SSF 6 - 75	6	14	19.5	75	52	18	0.31
SSF 8 - 75	8	18	23.5			24	0.34
SSF10 - 75	10	22	27.5			30	0.42
SSF12 - 75	12	24	29.5			34	0.43
HSK50A - SSF 4 - 75	4	10	15.0	75	46	12	0.51
SSF 6 - 75	6	14	19.0			18	0.61
SSF 8 - 75	8	18	23.0			24	0.64
SSF10 - 75	10	22	27.0			30	0.67
SSF12 - 75	12	24	29.0			34	0.69
SSF16 - 75	16	28	33.0			38	0.71
HSK63A - SSF 4 - 90	4	10	16.4	90	61	12	0.85
SSF 6 - 90	6	14	20.4	90	61	18	0.9
- 150			26.7	150	121		1.04
SSF 8 - 90	8	18	24.4	90	61	24	0.9
- 150			30.7	150	121		1.15
SSF10 - 90	10	22	38.4	90	61	30	1.0
- 150			34.7	150	121		1.29
SSF12 - 90	12	24	30.4	90	61	34	1.0
- 150			36.7	150	121		1.33
SSF16 - 90	16	28	34.4	90	61	40	1.0
- 165			42.3	165	136		1.7
SSF20 - 90	20	34	40.4	90	61	40	1.1
- 165			48.3	165	136		1.9
HSK100A - SSF 6 - 105	6	14	21.7	105	73	18	2.5
- 165	8	18	27.9	165	133	24	2.7
SSF 8 - 105			25.7	105	73		2.5
- 165	10	22	31.9	165	133	30	2.8
SSF10 - 105			29.7	105	73		2.6
- 165	12	24	35.9	165	133	34	2.9
SSF12 - 105			31.7	105	73		2.6
- 165	16	28	37.9	165	133	40	3.0
SSF16 - 105			35.7	105	73		2.7
- 165	20	34	41.9	165	133	40	3.1
SSF20 - 105			41.7	105	73		2.8
- 165			47.9	165	133		3.4

- ▶ 열박음홀더 사용시 절삭공구 Shank경은 h6의 제품을 사용해 주십시오.
- ▶ 절삭공구는 초경 Shank만 대응합니다. (하이스 제품 사용금지)
- ▶ 열박음홀더 사용시 지정된 고주파 히팅기를 사용해서 절삭공구 체결을 권장합니다.
- ▶ SELUX 고주파 히팅기는 **P153**
- ▶ 절삭공구 최소 삽입길이를 준수해 주시기 바랍니다.
- ▶ 공구길이조정 Stopper는 별도 판매 입니다. **P153**
- ▶ 내부급유 콜런트파이프는 **P100**
- ▶ 열박음척 사용시 척 내경에 있는 방청유를 제거후에 사용하셔야 합니다. 내구성 저하 원인이 됩니다.

- ▶ Please use only carbide cutting tools of a shank tolerance within H6.
- ▶ Please use only carbide cutting tools for shink fit holder. (Prohibit use HSS CUTTING TOOLS)
- ▶ We recommend shrink fit equipment when you use shink fit holder.
- ▶ SELUX shrink fit equipment is refered. **P153**
- ▶ Please follow minimum insertion lengh of the cutting tools.
- ▶ Stopper for adjusting cutting tool lengh order separately. **P153**
- ▶ The Coolant pipe are refered. **P100**
- ▶ Please clean the shank outside and inside of shrink fit before use. If you don't clean the shrink fit, it has problem about Run-out and toollife.

SHRINK FIT HOLDER

Coolant-through hole

Clamping Range : $\phi 4.0 \sim \phi 12.0$



CODE No.

HSK40E | SSF10 | S | 75
 Shank | Chucking Dia | Shim Length

MAX
40,000
 min⁻¹

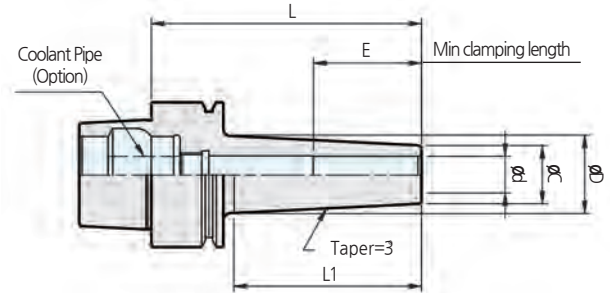

PRODUCT INFORMATION

- 4D선단에서 3 μ m이내의 흔들림 정도
- 높은 정밀도와 강력한 파지력
- 대칭적, 슬림한 디자인으로 가공최적화
- 전제품 내부급유 (Coolant Through Hole)
- 3 μ m(T.I.R) Run-out at 4D away from shank nose.
- Excellent Run-out accuracy and powerful clamping.
- Optimal operation with slim and symmetrical design.
- All products can be used for center through coolant type.

Code No.	ϕd	ϕC	ϕD	L	L1	E	Weight (kg)		
HSK25E - SSF 4S - 45	4	7	10.0	45	32	12	0.06		
SSF 6S - 60	6	11	15.0	60	47	18	0.08		
SSF 8S - 60	8	13	18.0			24	0.10		
HSK32E - SSF 4S - 60	4	7	10.0	60	37	12	0.14		
SSF 6S - 60	6	11	13.5			18	0.15		
SSF 8S - 60	8	13	16.5			24	0.16		
SSF10S - 60	10	16	20.0			30	0.18		
SSF12S - 60	12	19	23.0				0.19		
HSK40E - SSF 4S - 60	4	7	10.0	60	37	12	0.22		
SSF 6S - 75	6	11	15.0			18	0.24		
SSF 8S - 75	8	13	18.0					24	0.26
SSF10S - 75	10	16	21.0			30	0.29		
SSF12S - 75	12	19	24.0						
HSK50E - SSF 6S - 75	6	11	14.5	75	52	18	0.45		
SSF 8S - 75	8	13	17.5			24	0.46		
SSF10S - 75	10	16	20.5					30	0.48
SSF12S - 75	12	19	23.5			0.51			

- ▶ 열박음홀더 사용시 절삭공구 Shank경은 h6의 제품을 사용해 주십시오.
- ▶ 절삭공구는 초경 Shank만 대응합니다. (하이스 제품 사용금지)
- ▶ 열박음홀더 사용시 지정된 고주파 히팅기를 사용해서 절삭공구 체결을 권장합니다.
- ▶ SELUX 고주파 히팅기는 P153
- ▶ 절삭공구 최소 삽입길이를 준수해 주시기 바랍니다.
- ▶ 공구길이조정 Stopper는 별도 판매 입니다. P153
- ▶ 내부급유 쿨런트파이프는 P100
- ▶ 열박음척 사용시 척 내경에 있는 방청유를 제거후에 사용하셔야 합니다. 내구성 저하 원인이 됩니다.
- ▶ Please use only carbide cutting tools of a shank tolerance within H6.
- ▶ Please use only carbide cutting tools for shrink fit holder. (Prohibit use HSS CUTTING TOOLS)
- ▶ We recommend shrink fit equipment when you use shrink fit holder.
- ▶ SELUX shrink fit equipment is referred. P153
- ▶ Please follow minimum insertion length of the cutting tools.
- ▶ Stopper for adjusting cutting tool length order separately. P153
- ▶ The Coolant pipe are referred. P100
- ▶ Please clean the shank outside and inside of shrink fit before use. If you don't clean the shrink fit, it has problem about Run-out and tool life.

SSK COLLET CHUCK

Coolant-through hole
Clamping Range : $\phi 1.0 \sim \phi 25.4$

CODE No.

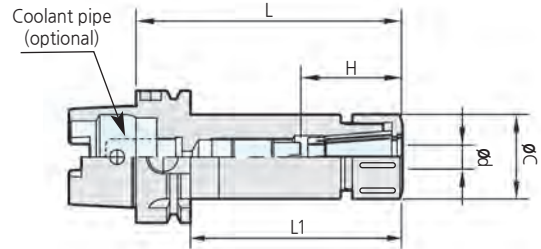
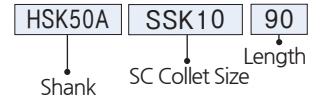

PRODUCT INFORMATION

- 8, Taper 의 강력한 파지력
- 높은 정밀도와 빠른 가공에 적합
- 드릴, 센터드릴, 엔드밀, 탭, 리머용으로 사용
- Powerful clamping force of 8, taper.
- Excellent Run-out Accuracy.
- SSK COLLET CHUCK is suitable for a various operation using drill, endmill, tap and reamer.

Code No.	ϕd	L	C	H		L1	Weight (kg)			
				Min	Max					
HSK40A - SSK 6 - 60	0.9~6.0	60	19.5	40		40	0.3			
SSK10 - 60	1.75~10.0			27.5	29		36	0.35		
SSK13 - 75		2.75~13.0	75		33	55		55	0.4	
SSK16 - 90	2.75~16.0			40		60			70	0.5
SSK10 - 90						1.75~10.0	19.5			37
SSK13 - 90	2.75~13.0	90	27.5	35				64	0.4	
SSK16 - 90				2.75~16.0	40	36	41		0.5	
SSK10 - 60						1.75~10.0	19.5		31	47
SSK13 - 105	2.75~13.0	105	33	50				79	1.0	
SSK16 - 105				2.75~16.0	40	58			94	1.2
SSK20 - 120						3.5~20.0	120			64
SSK25 - 125	15.5~25.4	125	55		99			1.1		
SSK10 - 125			1.75~10.0	125		27.5	60		99	1.2
SSK13 - 135	2.75~13.0	135			65		106	1.3		
SSK16 - 140					2.75~16.0			140		66
SSK20 - 150	3.5~20.0	150	48	70		111	1.9			
SSK25 - 155				15.5~25.4	155		75		126	2.9
SSK10 - 125							1.75~10.0	125		27.5
SSK13 - 135	2.75~13.0	135	80		126	3.4				
SSK16 - 140			2.75~16.0	140		81			126	
SSK20 - 150	3.5~20.0	150			48	82		126		3.5
SSK25 - 155			15.5~25.4	155		55	83		126	5.0

- ▶ 너트, 조절나사 및 콜릿추출도구는 부속되어 있습니다.
- ▶ 스페너는 별매입니다. P157
- ▶ Synchronized Tap 사용시 SSK10을 사용하십시오.
Aluminum MAX Tapping M12
Steel MAX Tapping M10
Stainless Steel MAX Tapping M8
위 사양 이상인경우는 Milling Chuck에 K-Collet을 사용하시길 바랍니다.
- ▶ SSK척 콜릿은 P144~P145
- ▶ 절삭공구 체결시 무리한 힘이 가해질시 너트 및 홀더가 파손 될 수 있습니다.
- ▶ 고속 바란스 작업시 추가 비용이 청구됩니다.
- ▶ 내부규유 콜릿트파이프는 P100
- ▶ NUT, ADJUST SCREW, COLLET REMOVER are included.
- ▶ Spanner is ordered separately. P157
- ▶ Please use SSK10 when you use Synchronized Tap.
Aluminum MAX Tapping M12
Steel MAX Tapping M10
Stainless Steel MAX Tapping M8
If it has problem, We recommend K COLLET with Milling Chuck.
- ▶ SC COLLET is referred. P144~P145
- ▶ The nut or shank of chuck can be destoried if you too strongly clamp nut and holder.
- ▶ Extra charge for high speed balance.
- ▶ The Coolant pipe are referred. P100

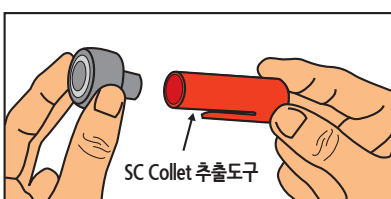

SSK Chuck NUT에 SC Collet 체결시에는 전용 콜릿 추출 도구를 사용하시기 바랍니다.

Please use private remover when you insert the SSK COLLET in SSK NUT

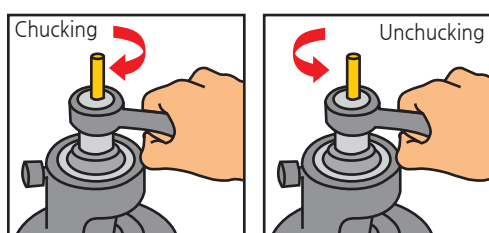

SSK Collet chuck은 Nut와 Body 체결시 40 Torque 이상의 힘이 가해질시 너트 및 바디가 파손될 수 있습니다. ※주의 (SSK6, SSK10)

SSK NUT and SSK CHCUK is possible to be broken if you clamp chuck and nut over 40 Torque (※ WARNING SSK6, SSK10)

GSK COLLET CHUCK



Coolant-through hole
Clamping Range : $\phi 1.0 \sim \phi 25.4$



CODE No.

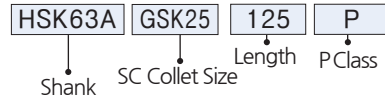

MAX
40,000
min⁻¹

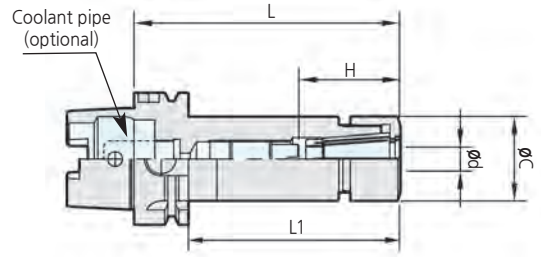

PRODUCT INFORMATION

- 고속가공에서 높은 정도
- 8, Taper의 강력한 파지력
- 원형 너트로 컴팩트한 디자인
- 스페너는 PH스패너 사용(별매)
- G2.5X max 40,000 RPM
- 고속형GSK척에는 P CLASS 콜릿 사용을 권장
- Excellent Run-out Accuracy.
- Powerful clamping force of 8, Taper.
- Circle style nut designed compactly
- PH spanner is orderd seperately.
- G2.5X max 40,000 RPM.
- We recommed to use P CLASS SC COLLET when you use GSK CHCUK.

Code No.	ϕd	L	C	H		L1	Weight (kg)
				Min	Max		
HSK40A - GSK 6 - 60P	0.9 ~ 6.0	60	19.5	40		40	0.3
GSK10 - 60P	1.75 ~ 10.0			27.5	29 36		55
- 75P		2.75 ~ 13.0	33		55		
GSK13 - 75P	2.75 ~ 16.0			40	60		64
GSK16 - 90P		0.9 ~ 6.0	60		19.5	37	
HSK50A - GSK 6 - 60P	1.75 ~ 10.0			27.5		35	
GSK10 - 60P		2.75 ~ 13.0	90		33	36	41
- 90P	2.75 ~ 16.0			40		50 58	
GSK13 - 90P		0.9 ~ 6.0	90		19.5	26	31
GSK16 - 90P	1.75 ~ 10.0			27.5		33 41	
HSK63A - GSK 6 - 90P		2.75 ~ 13.0	105		33	31	47
GSK10 - 105P	2.75 ~ 16.0			40		50 58	
GSK13 - 105P		3.5 ~ 20.0	120		48	50	55
GSK16 - 105P	15.5 ~ 25.4			125		55	60
GSK20 - 120P		0.9 ~ 6.0	120		19.5		26
GSK25 - 125P	1.75 ~ 10.0			125		27.5	33
HSK100A - GSK 6 - 120P		2.75 ~ 13.0	135		33		39
GSK10 - 125P	2.75 ~ 16.0			140		40	46
GSK13 - 135P		3.5 ~ 20.0	150		48		48
GSK16 - 140P	15.5 ~ 25.4			155		55	60
GSK20 - 150P		0.9 ~ 6.0	120		19.5		26
GSK25 - 155P	1.75 ~ 10.0			125		27.5	33
		2.75 ~ 13.0	135		33		39
	2.75 ~ 16.0			140		40	46
		3.5 ~ 20.0	150		48		48
	15.5 ~ 25.4			155		55	60

- ▶ 너트, 조절나사 및 콜릿추출도구는 부속되어 있습니다.
- ▶ 스페너는 별매입니다. **P157**
- ▶ GSK척 콜릿은 **P144~P145**
- ▶ 절삭공구 체결시 무리한 힘이 가해질시 너트및 홀더가 파손 될 수 있습니다.
- ▶ 내부급유 콜러트파이프는 **P100**
- ▶ NUT, ADJUST SCREW, COLLET REMOVER are included.
- ▶ Spanner is ordered separately. **P157**
- ▶ P CLASS SC COLLET for GSK CHUCK is refered. **P144 ~ P145**
- ▶ The nut or shank of chuck can be destoried if you too strongly clamp nut and holder
- ▶ The Coolant pipe are refered. **P100**

GSK COLLET CHUCK



Coolant-through hole
Clamping Range : $\phi 1.0 \sim \phi 16.0$



CODE No.

HSK40E | GSK10 | 60 | P
Shank | SC Collet Size | Length | P Class

MAX
40,000
min⁻¹

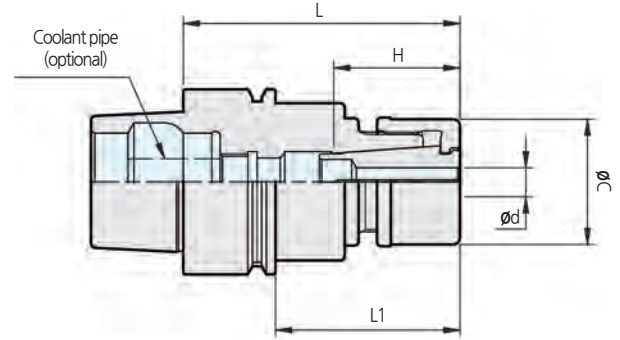

PRODUCT INFORMATION

- 고속가공에서 높은 정도
- 8. Taper의 강력한 파지력
- 원형 너트로 컴팩트한 디자인
- 스패너는 PH스패너 사용(별매)
- G2.5X max 40.000 RPM
- 고속형GSK척에는 P CLASS 콜릿 사용을 권장
- Excellent Run-out Accuracy.
- Powerful clamping force of 8. taper.
- Circle style nut designed compactly
- PH spanner is orderd seperately.
- G2.5X max 40.000 RPM.
- We recommed to use P CLASS SC COLLET when you use GSK CHCUK.

Code No.	ϕd	L	C	H	L1	MAX rpm	Weight (kg)
HSK25E - GSK 6 - 45P	0.9 ~ 6.0	45	19.5	30.5	35	40,000	0.1
GSK10 - 55P	1.75~10.0	55	27.5	41	45		0.2
HSK32E - GSK 6 - 50P	0.9 ~ 6.0	50	19.5	32	29	40,000	0.2
GSK10 - 60P	1.75~10.0	60	27.5	44	41		0.3
HSK40E - GSK 6 - 60P	0.9 ~ 6.0	60	19.5	40	37	30,000	3.0
GSK10 - 60P	1.75~10.0		27.5		39		0.4
GSK13 - 75P	2.75~13.0		33	55	54		0.6
GSK16 - 80P	2.75~16.0		40	59	59		0.6
HSK50E - GSK 6 - 60P	0.9 ~ 6.0	60	19.5	40	33	25,000	0.5
GSK10 - 60P	1.75~10.0		27.5	35			0.5
GSK13 - 70P	2.75~13.0		70	33	47	43	25,000
GSK16 - 80P	2.75~16.0	80	40	52	53	1.2	

- ▶ 너트, 조절나사 및 콜릿추출도구는 부속되어 있습니다.
- ▶ 스패너는 별매입니다. **P157**
- ▶ GSK척 콜릿은 **P144~P145**
- ▶ 절삭공구 체결시 무리한 힘이 가해질시 너트및 홀더가 파손 될 수 있습니다.
- ▶ 내부급유 콜러트파이프는 **P100**
- ▶ NUT, ADJUST SCREW, COLLET REMOVER are included.
- ▶ Spanner is ordered separately. **P157**
- ▶ P CLASS SC COLLET for GSK CHUCK is refered. **P144 ~ P145**
- ▶ The nut or shank of chuck can be destoried if you too strongly clamp nut and holder
- ▶ The Coolant pipe are refered. **P100**

ER COLLET CHUCK



Coolant-through hole
Clamping Range : $\phi 0.5 \sim \phi 26.0$



CODE No.

HSK63A ER16 95
Shank ER Collet Size Length

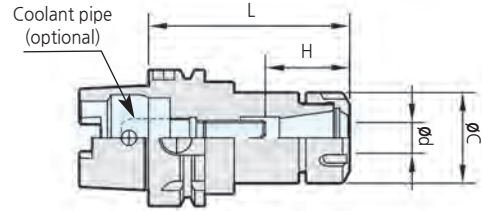

PRODUCT INFORMATION

- 안정적인 정밀도와 파지력
- 쉽고 빠른 공구교환
- 드릴, 엔드밀, 탭 다양한 사용범위

- Reliable accuracy and Powerful clamping force.
- Easy and quick tool exchange.
- ER COLLET CHUCK is suitable for a various operation using drill, endmill, tap.

Code No.	ϕd	L	ϕC	H		Collet	Weight (kg)
				Min	Max		
HSK50A - ER11 - 75	0.5 ~ 7.0	75	19	19	34	ER11	0.5
ER16 - 90	0.5 ~ 10.0	90	28	23	43	ER16	0.6
ER20 - 95	1.0 ~ 13.0	95	35	25	48	ER20	0.7
ER25 - 100	1.0 ~ 16.0	100	42	34	54	ER25	0.8
ER32 - 105	2.0 ~ 20.0	105	50	40	60	ER32	0.9
HSK63A - ER11 - 80	0.5 ~ 7.0	80	19	19	34	ER11	0.8
ER16 - 95	0.5 ~ 10.0	95	28	23	43	ER16	1.0
ER20 - 100	1.0 ~ 13.0	100	35	25	48	ER20	1.1
ER25 - 105	1.0 ~ 16.0	105	42	34	54	ER25	1.2
ER32 - 110	2.0 ~ 20.0	110	50	40	60	ER32	1.4
ER40 - 120	3.0 ~ 26.0	120	63	50	80	ER40	1.8
HSK100A - ER11 - 85	0.5 ~ 7.0	85	19	19	34	ER11	2.4
ER16 - 95	0.5 ~ 10.0	95	28	23	43	ER16	2.7
ER20 - 105	1.0 ~ 13.0	105	35	25	48	ER20	3.0
ER25 - 110	1.0 ~ 16.0	110	42	34	54	ER25	3.2
ER32 - 120	2.0 ~ 20.0	120	50	40	60	ER32	3.4
ER40 - 130	3.0 ~ 26.0	130	63	50	80	ER40	3.6

Spare Parts				
Type	Option			
	NUT	Adjust Screw	Spanner	ER Collet
ER11	UM/ER11(HEXA)	BTD0716-C	ER11-SP	ER11- ϕ
ER16	UM/ER16(HEXA)	BTD1025-C	ER16-SP	ER16- ϕ
ER20	UM/ER20(HEXA)	BTD1325-C	ER20-SP	ER20- ϕ
ER25	UX/ER25	BTD1830-C	ER25-SP	ER25- ϕ
ER32	UX/ER32	BTD2230-C	ER32-SP	ER32- ϕ
ER40	UX/ER40	BTD2838-C	ER40-SP	ER40- ϕ

- ▶ 내부급유 사용시에는 방수형콜릿이나 방수형 너트를 사용 해주십시오.
- ▶ ER콜릿은 P146
- ▶ 스패너는 별매입니다. P157
- ▶ 고속 바란스 작업시 추가 비용이 청구됩니다.
- ▶ ER척 스페어 파트는 P56
- ▶ 내부급유 콜릿트 파이프는 P100
- ▶ Please use waterproof collet and waterproof nut for operating centre through coolant type.
- ▶ ER COLLET is referred. P46
- ▶ Spanner is ordered separately. P157
- ▶ Extra charge for high speed balance.
- ▶ The spare parts for ER CHCUK are referred. P56
- ▶ The Coolant pipe are referred. P100

ENDMILL COLLET CHUCK



Coolant-through hole
Clamping Range : $\phi 6.0 \sim \phi 20.0$

CODE No.

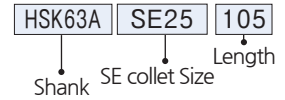
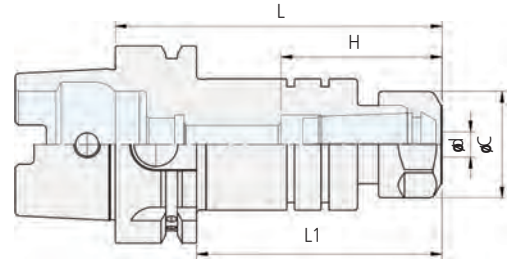

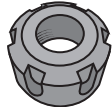
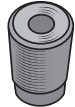

Fig1



PRODUCT INFORMATION

- SE척 전용 콜릿 사용
- ENDMILL 전용 COLLET CHUCK
- 4도 TAPER의 강력한 파지력
- 5 μ m at 4D (T.I.R) (Max G2.5 at 20,000 rpm)
- Please use dedicated collet for SE COLLET CHUCK
- SE COLLET CHUCK for dedicated ENDMILL
- Strong Clamping Power of 4 degree TAPER
- 5 μ m at 4D (T.I.R) (Max G2.5 at 20,000 rpm)

CODE NO.	ϕd	ϕC	H	L	L1	Collet	Weight (kg)	Fig
HSK63A - SE20 - 100	6,8,10,12	34	40.5	100	74	SE20	1.2	1
HSK63A - SE25 - 105	6,8,10,12,16	42	48	105	79	SE25	1.4	
HSK63A - SE32 - 110	6,8,10,12,16,20	50	58	110	84	SE32	1.6	
HSK100A - SE20 - 105	6,8,10,12	34	40.5	100	74	SE20	2.3	
HSK100A - SE25 - 110	6,8,10,12,16	42	48	105	79	SE25	2.5	
HSK100A - SE32 - 120	6,8,10,12,16,20	50	58	110	84	SE32	2.7	

Spare Parts				
Type	Option			
	NUT	Adjust Screw	Spanner	SE Collet
SE20				
SE25	UM/SE20(HEXA)	BTD1325-C	SE20-SP	SE20- ϕ
SE32	UX/SE25	BTD1830-C	SE25-SP	SE25- ϕ
	UX/SE32	BTD2230-C	SE32-SP	SE32- ϕ

- ▶ SE NUT와 ER NUT은 호환성이 있으나 SE너트로 별도 구매 바랍니다. (ER NUT를 SE CHUCK에 사용을 금지합니다.)
- ▶ 스패너는 별도 구매입니다.
- ▶ SE콜릿은 P146
- ▶ Nut has compatible with SE NUT and ER NUT. But Please order separately when you need NUT. (Prohibit that SE CHUCK use ER NUT)
- ▶ Spanner is ordered separately
- ▶ SE COLLET is referred. P146

SYNCHRO TAPPING CHUCK



Coolant-through hole
Clamping Range : M2.0 ~ M22.0

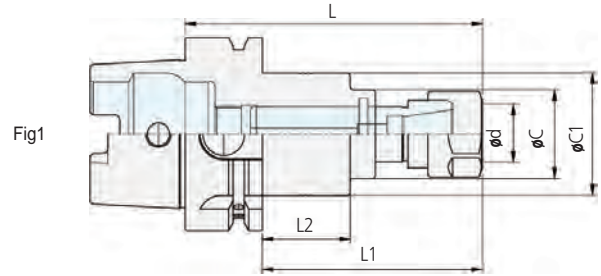
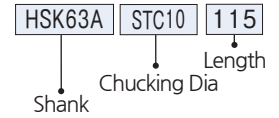

CODE No.



PRODUCT INFORMATION

- 고속 가공용 TAPPING CHUCK (Max. G6.3 at 10,000 rpm)
- 4D x 25 μ m(T.I.R)
- 특수 설계로 인한 TAP 파손 방지
- ER TAP COLLET 사용 권장 (STC3 은 일반 ER11 COLLET)
- TAPPING CHUCK for high speed. (Max. G6.3 at 10,000 rpm)
- 4D x 25 μ m(T.I.R)
- Special designed Tapping chuck for Tapping
- recommend ER TAP COLLET When you use Synchro tapping chuck (STC3 use ER11 collet)

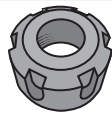
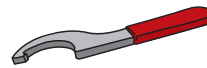
CODE NO.	ϕd	ϕC	$\phi C1$	L	L1	L2	Collet	Weight (kg)	Fig
HSK63A - STC 10 - 100	M2~M10	29	40	100	74	29.5	TER16	1.2	1
- STC 22 - 115	M4~M22	42	53	115	89	29	TER32	1.6	
HSK100A - STC 10 - 105	M2~M10	29	40	105	76	31.5	TER16	2.7	
- STC 22 - 140	M4~M22	42	54	140	111	50	TER32	3.9	

Spare Parts			
Type	Option		
	NUT	Spanner	TER Collet
STC 3	 UM/ER11(HEXA)	 ER11-SP	 ER11- ϕ
STC 10	UM/ER16(HEXA)	ER16-SP	TER16- ϕ
STC 22	UX/ER32	ER32-SP	TER32- ϕ

- ▶ 스패너는 별매입니다.
- ▶ 동기화 기능(리지드)이 있는 장비에서 사용 가능합니다.
- ▶ ER콜릿은 P146
- ▶ TER콜릿은 P148

- ▶ Spanner is ordered separately.
- ▶ The machining Center has Synchro function (RIGID TAP) to use STC CHUCK
- ▶ ER COLLET is referred. P146
- ▶ TER COLLET is referred. P148

TAPPING CHUCK HOLDER



Tapping Range : M3 ~ M36

CODE No.

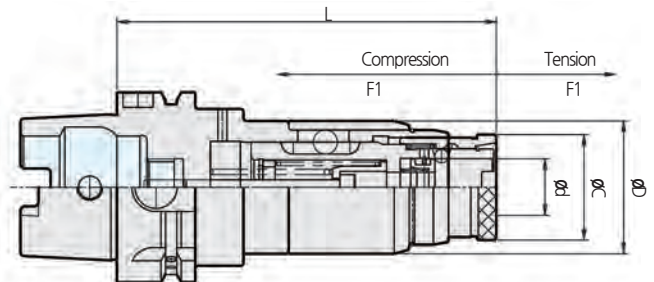
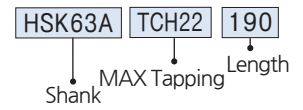

HSK SHANK TAPPING CHUCK HOLDER

PRODUCT INFORMATION

- 플로팅 타입으로 인장수축 장치 내장
- 공구교환이 빠르고 편리함
- 관통구멍과 막힌구멍의 tapping 및 모든 tap 작업 가능
- The tapping chuck is equipped with tension system by floating type.
- Easy and quick tool exchange.
- It is possible for tapping operation of blind hole and through hole.

Code No.	ød	øD	L	øC	H		Weight (kg)
					Min	Max	
HSK 63A - TCH12 - 150	19	44	125	35	6	12	3.3
TCH22 - 190	31	63	155	52	10	15	5.1
HSK100A - TCH12 - 160	19	44	135	35	6	12	4.5
TCH22 - 200	31	63	165	52	10	15	6.1
TCH36 - 300	48	67	255	83	15	20	11.3

▶ 적용 탭콜릿은 P149

▶ Private tap collets are referred. P149

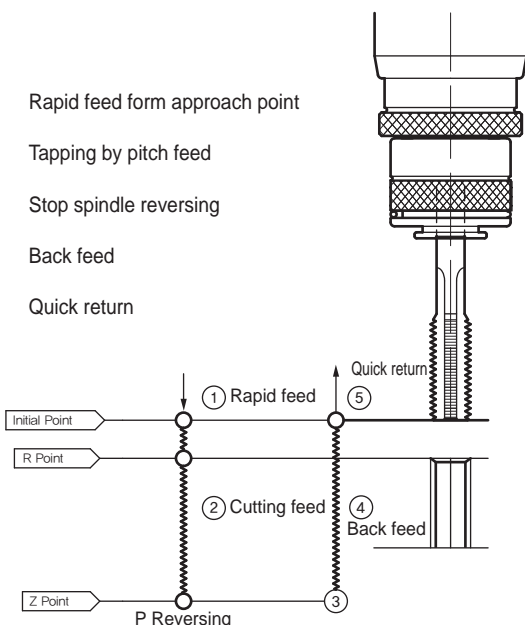

NC DRILL CHUCK



Clamping Range : $\phi 0.5 \sim \phi 13.0$

CODE No.

HSK63A NPU13 150
 ↓ ↓ ↓
 Shank Chucking Dia Length

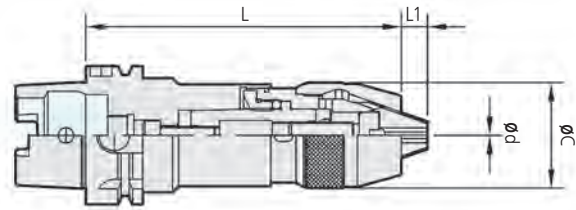

PRODUCT INFORMATION

머시닝 센터의 일반적인 드릴링 공구입니다. **General Drillings for Machining Centers**

- 척과 샹크가 일체형 구조로 길이가 짧음
- 가공정도 향상과 우수한 내구성
- 척의 탈락이 없고 주축 정지시 풀리지 않음
- Unified body of chuck and shank reduces the length of tool.
- Improved operation accuracy and excellent rigidity
- The drillchuck is never detached from holder and is not released when the operation is stop.

Code No.	ϕd	L	ϕC	L1	Weight (kg)
HSK50A - NPU 8 - 135	0.3 ~ 8.0	135	38	8.5	1.4
HSK63A - NPU 8 - 135	0.3 ~ 8.0	135	38	8.5	1.8
NPU13 - 150	1.0 ~ 13.0	150	50	11.5	2.2
HSK100A - NPU 8 - 135	0.3 ~ 8.0	135	38	8.5	3.5
NPU13 - 165	1.0 ~ 13.0	165	50	11.5	4.4

Spare Parts

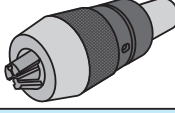
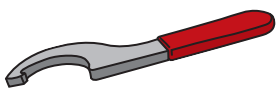
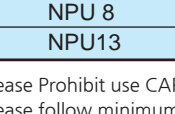
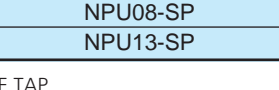
Type	Basic	
	Chuck	Spanner
NPU 8		
NPU13		
	NPU 8	NPU08-SP
	NPU13	NPU13-SP

- ▶ 초경 드릴, 탭은 절대 사용을 금지해 주십시오.
- ▶ 절삭공구 최소 척킹 길이를 준수해 주시기 바랍니다.
 NPU8-20mm이상
 NPU13-30mm이상
- ▶ 스페너는 별매입니다. **P157**
- ▶ Please Prohibit use CARBIDE DRILL and CARBIDE TAP.
- ▶ Please follow minimum length of cutting tools.
 NPU8 : more 20mm
 NPU13 : more 30mm
- ▶ Spanner is ordered separately. **P157**

SIDE LOCK HOLDER

Coolant-through hole
Clamping Range : $\phi 6.0 \sim \phi 42.0$

CODE No.

HSK63A SLA32 125
Shank Chucking Dia Length



TAPER 접촉율 80% 이상 진동없음.

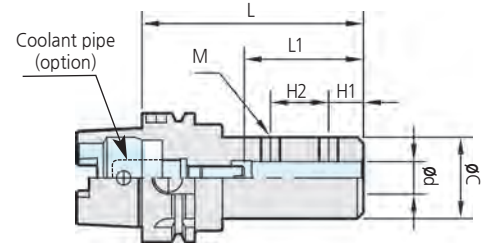

PRODUCT INFORMATION

■ Drill, endmill, 기타(small chuck, special tool)등을 사용할 수 있습니다 ■ SIDE LOCK HOLDER can use tool holder for drill, endmill, etc.

Code No.	Ød	L	ØC	L1		H1	H2	M	Weight (kg)
				Min	Max				
HSK63A - SLA 6 - 75	6	75	25	20	35	18	-	M 5	1.0
SLA 8 - 80	8	80	28	25	40			M 6	1.2
SLA10 - 90	10	90	35	35	50	14	13	M 8	1.2
SLA12 - 90	12		40				16		
SLA14 - 105	14	105	42	50	65	20	20	M12	1.4
SLA16 - 105	16		44						
SLA20 - 115	20	115	48	55	68	25	25	M16	1.7
SLA25 - 115	25								
SLA32 - 120	32	120	63	65	80	25	25	M16	2.2
SLA40 - 125	40		76						
SLA42 - 125	42	125	80						2.6
HSK100A - SLA 6 - 80	6	80	25	20	35	18	-	M 5	3.1
SLA 8 - 85	8	85	28	25	40			M 6	3.1
SLA10 - 95	10	95	35	35	50	14	13	M 8	3.3
SLA12 - 95	12		40				16		
SLA14 - 110	14	110	42	50	65	20	20	M12	3.5
SLA16 - 110	16		44						
SLA20 - 120	20	120	48	60	75	25	25	M14	3.8
SLA25 - 120	25								
SLA32 - 125	32	125	63	65	80	25	25	M16	4.0
SLA40 - 135	40		76						
SLA42 - 135	42	135	80						4.5

▶ 사이드락홀더 스페어 파트는 P64
▶ 내부급유 쿨런트 파이프는 P100

▶ The spare parts for SIDE LOCK HOLDER are referred. P64
▶ The Coolant pipe are referred. P100

MORSE TAPER HOLDER

■ for Morse taper shank with tang.



CODE No.

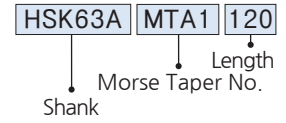

TAPER 접촉을 80% 이상 진동없음.

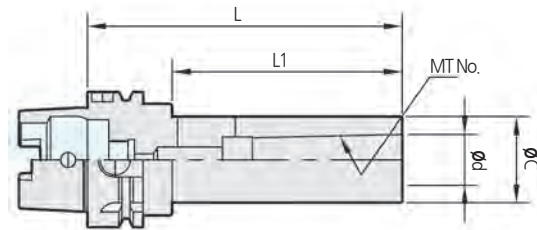

PRODUCT INFORMATION

■ Drill reamer, 기타(MT Shank type tool)등을 사용할 수 있습니다.

■ MORSE TAPER HOLDER can use tool holder for drill, reamer, etc.

Code No.	ød	MT No.	øC	L	L1	Weight (kg)
HSK 63A - MTA1 - 120	12.065	1	25	120	78	1.5
MTA2 - 135	17.780	2	32	135	93	1.5
MTA3 - 150	23.825	3	40	150	108	1.6
MTA4 - 165	31.267	4	50	165	123	1.8
HSK100A - MTA1 - 120	12.065	1	25	120	75	2.0
MTA2 - 135	17.780	2	32	135	90	2.0
MTA3 - 155	23.825	3	40	155	110	2.1
MTA4 - 180	31.267	4	50	180	135	2.4
MTA5 - 220	44.399	5	65	220	175	2.9

Drill Dia and Shank

Shank		MT1	MT2	MT3	MT4	MT5
Drill dia	Min	3.0	14.5	23.5	32.0	51.0
	Max	14.0	23.0	31.5	50.0	76.0

FACE MILL ARBOR



CODE No.
 HSK63A FMA25.4 60
 Shank Cutter Type Length

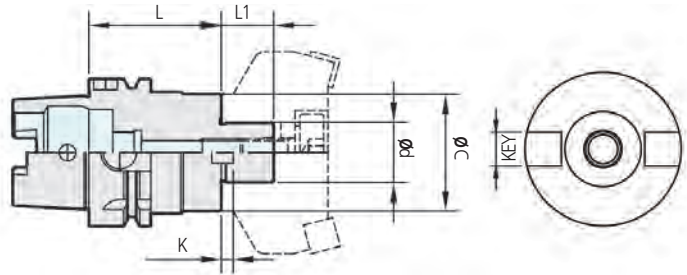

PRODUCT INFORMATION

■ JIS B4113 face milling용입니다.

■ For face-milling cutter conforming to JIS B4113.

FMA Type

Code No.	ød	Cutter Dia	L	øC	L1	Key	K	Weight (kg)
HSK 63A - FMA25.4 - 60	25.4	80	60	50	22	K 9.5-L	5	1.0
FMA31.75 - 65	31.75	100	65	60	30	K12.7-L	7	1.3
FMA38.1 - 70	38.1	125	70	80	34	K15.87-L	9	1.7
HSK100A - FMA25.4 - 60	25.4	80	60	50	22	K 9.5-L	5	2.4
FMA31.75 - 65	31.75	100	65	60	30	K12.7-L	7	3.0
FMA38.1 - 75	38.1	125	75	80	34	K15.87-L	9	3.9
FMA50.8 - 80	50.8	160	80	100	36	K19-L	10	4.3
FMA47.625 - 95	47.625	200	95	128	38	K25.4	12.5	4.8

FMC Type

Code No.	ød	Cutter Dia	L	øC	L1	Key	K	Weight (kg)
HSK 63A - FMC16 - 55	16	40	55	38	17	K8-L	5	1.2
FMC22 - 60	22	50.63	60	45	18	K10-L	5.5	1.2
FMC27 - 65	27	63.80	65	60	20	K12-L	6	1.4
FMC32 - 75	32	100	75	85	22	K14-L	7	2.0
HSK100A - FMC22 - 60	22	50.63	60	45	18	K10-L	5.5	2.5
FMC27 - 65	27	63.80	65	60	20	K12-L	6	2.8
FMC32 - 75	32	100	75	85	22	K14-L	7	3.0

▶ 페이스밀아바스페어파트는 P75

▶ The spare parts for FACE MILL ARBOR are referred. P75

FACE MILL ARBOR (COOLANT TYPE)

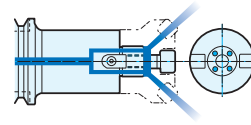

CODE No.

HSK63A	FMH22	60
Shank	Cutter Type	Length

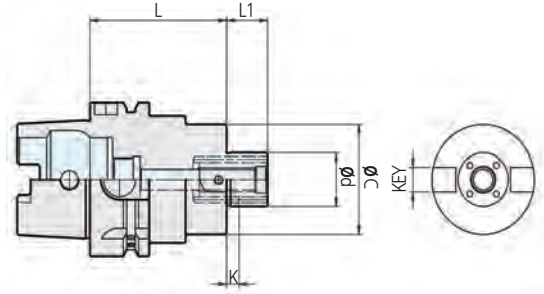

PRODUCT INFORMATION

- 쿨런트 컷터 전용
- Only use coolant cutter.
- 컷터 가공성 향상 공구사용시간 증가
- Improve tool life and cutting operation

Code No.	ød	øC	L	L1	K	KEY	Weight (kg)
HSK40A - FMH22 - 50	22	45	50	18	5.5	K10-L	0.6
FMH25.4 - 50	25.4	50	50	22	5	K9.5-L	0.6
HSK50A - FMH22 - 60	22	45	60	18	5.5	K10-L	1.0
FMH25.4 - 60	25.4	50	60	22	5	K9.5-L	1.1
HSK63A - FMH22 - 60	22	45	60	18	5.5	K10-L	1.3
FMH25.4 - 60	25.4	50	60	22	5	K9.5-L	1.3
FMH27 - 65	27	60	65	20	6	K12-L	1.4
FMH31.75 - 65	31.75	60	65	30	7	K12.7-L	1.5
HSK100A - FMH22 - 60	22	45	60	18	5.5	K10-L	2.9
FMH27 - 65	27	60	65	20	6	K12-L	3.2
FMH32 - 75	32	85	75	22	7	K14-L	3.8
FMH25.4 - 60	25.4	50	60	22	5	K9.5-L	3.2
FMH31.75 - 65	31.75	60	65	30	7	K12.7-L	3.6
FMH38.1 - 75	38.1	80	75	34	9	K15.87-L	4.5

- ▶ FMH 클램프볼트 및 부품은 일반 FMA, FMC 아바와 호환합니다.
- ▶ 페이스밀아바 스페어 파트는 P75
- ▶ 내부급유 쿨런트 파이프는 P100

- ▶ FMH clamp bolt and other parts is compatible with FACE MILL ARBOR FMA, FMC.
- ▶ The spare parts for FACE MILL ARBOR are referred. P75
- ▶ The Coolant pipe are referred. P100

CENTER THROUGH COOLANT PIPE

Taper	Code No.	Wrench
HSK 40	HSK 40-CP	HSK 40-CPW
HSK 50	HSK 50-CP	HSK 50-CPW
HSK 63	HSK 63-CP	HSK 63-CPW
HSK100	HSK100-CP	HSK100-CPW



Excellent Precision
Excellent Quality

SELUX
NC TOOLING SYSTEM

SK

CHUCK & Item

HYDRAULIC CHUCK
MILLING CHUCK
SHRINK FIT HOLDER
SSK COLLET CHUCK
ER COLLET CHUCK
NC DRILL CHUCK
TAPPING CHUCK HOLDER
JACOBS TAPER ARBOR
SIDE LOCK HOLDER
PRO MILL ARBOR
PRO MILL CUTTER (BALL TYPE)
MORSE TAPER HOLDER
FACE MILL ARBOR



HYDRAULIC CHUCK



Coolant-through hole
Clamping Range : $\phi 3.0 \sim \phi 32.0$

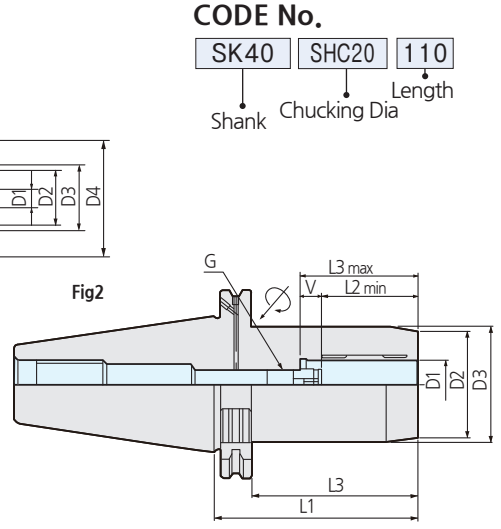
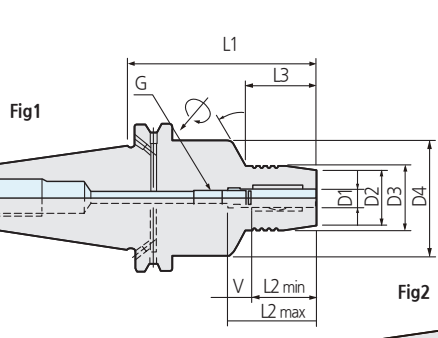
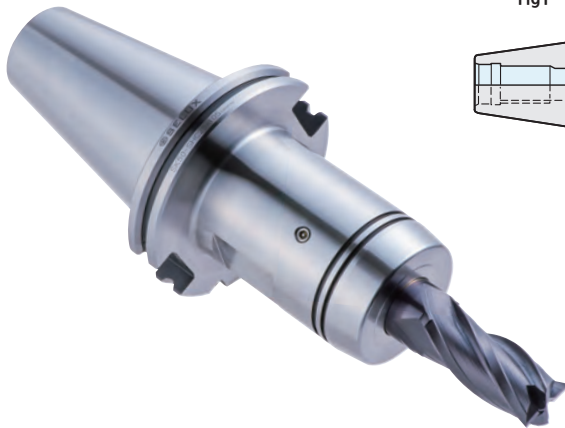

CODE No.

SK40	SHC20	110
------	-------	-----

Shank Chucking Dia Length

PRODUCT INFORMATION

- 4D 선단에서 3 μ m 이내의 흔들림 정도
- 높은 정밀도와 고속가공에 최적화
- 유압방식의 강력한 파지력
- 렌치 하나로 쉽게 공구고정
- 3 μ m(T.I.R) Run-out at 4D away from shank nose.
- The optimal chck for excellent accuracy and high speed operation.
- Powerful clamping force of hydraulic type.
- Easy clamping with just one wrench.

ID	Wrench
SHC 6~20 ϕ	4mm
SHC 25~30 ϕ	5mm

CODE NO.	D1	D2	D3	D4	L1	L2min	L2max	V	L3	G	Type	Weight (kg)		
SK40 - SHC 6 - 80.5	6	25	28	50	80.5	27.5	37.5	10	44	M5X0.8	Fig1	1.4		
- 110					110							2.0		
SHC 8 - 80.5	8	27	30		80.5	32.5	42.5					48	M6X1.0	1.4
- 110					110									2.0
SHC 10 - 80.5	10	29	32		80.5	37.5	47.5					30	M8X1.0	1.5
- 110					110									2.1
SHC 12 - 80.5	12	31	34		80.5	42.5	52.5					48	M8X1.0	1.5
- 110					110									2.1
SHC 14 - 80.5	14	33	36		80.5	51.0	61.0					26	M16X1.0	2.1
- 110					110									2.1
SHC 16 - 80.5	16	35	38	80.5	55.0	65.0	44	M16X1.0	1.5					
- 110				110					2.1					
SHC 18 - 80.5	18	38	41	80.5	55.0	65.0	48	M16X1.0	1.5					
- 110				110					2.1					
SHC 20 - 80.5	20	40	43	80.5	55.0	65.0	48	M16X1.0	1.5					
- 110				110					2.1					
SHC 25 - 80.5	25	53	57	66	51.0	61.0	85.9	M16X1.0	1.9					
- 110				80					55.0	65.0	2.0			
SHC 32 - 80.5	32	63	63	80	55.0	65.0	120.9	M16X1.0	2.0					
- 110				110					5.5					
SK50 - SHC 6 - 90	6	25	28	50	90	27.5	37.5	10	44	M5X0.8	Fig1	3.9		
- 140					140							4.5		
SHC 8 - 90	8	27	30		90	32.5	42.5					48	M6X1.0	3.9
- 140					140									4.5
SHC 10 - 90	10	29	32		90	37.5	47.5					48	M6X1.0	3.9
- 140					140									4.5
SHC 12 - 90	12	31	34		90	42.5	52.5					44	M8X1.0	4.0
- 140					140									4.6
SHC 14 - 90	14	33	36		90	51.0	61.0					44	M8X1.0	4.0
- 140					140									4.6
SHC 16 - 90	16	35	38	90	55.0	65.0	48	M8X1.0	4.1					
- 140				140					4.7					
SHC 18 - 90	18	38	41	90	55.0	65.0	48	M8X1.0	4.1					
- 140				140					4.7					
SHC 20 - 80.5	20	40	43	80.5	55.0	65.0	48	M8X1.0	4.1					
- 90				90					4.2					
- 110	110	4.7												
- 140	140	5.5												
SHC 25 - 105	25	53	57	-	105	51.0	61.0	85.9	M16X1.0	Fig2	5.0			
- 140				140	120.9						6.2			
SHC 32 - 115	32	58	63	-	115	55.0	65.0	95.9	M16X1.0	Fig2	5.2			
- 140				140	120.9						6.4			

SK SHANK
HYDRAULIC CHUCK

MILLING CHUCK



Coolant-through hole
Clamping Range : $\phi 3.0 \sim \phi 42.0$

CODE No.

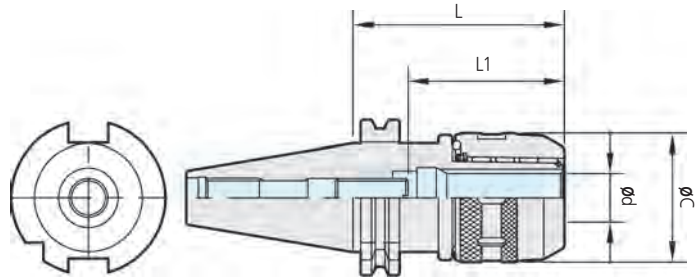
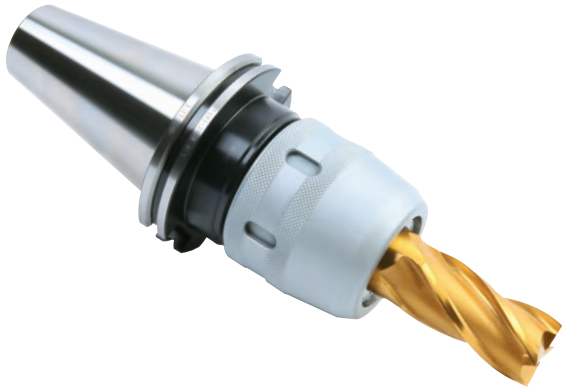
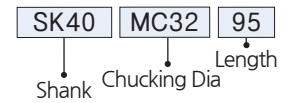

PRODUCT INFORMATION

- 높은 정밀도
- 간편한 척킹 시스템
- Taper 접촉 80% 이상 Taper공차 AT3로 보증
- 완전한 단면 밀착으로 강력 절삭
- 4배열 Roller System 방식으로 강력한 파지력

- Excellent Run-out Accuracy.
- Easy chucking system.
- More than 80% taper contact, we guarantee taper tolerance AT3.
- The strongest cutting power due to perfect face contact construction.
- Powerful clamping force by 4 needle roller system.

Code No.	ϕd	L	ϕC	L1	Collet	Weight (kg)
SK40 - MC20 - 90	20	90	53	82	K20	2.0
- 105		105		95		2.0
- 120		120		105		2.2
MC32 - 95	32	95	72	85	K32	2.9
- 105		105		95		3.0
- 120		120		105		3.2
SK50 - MC20 - 105	20	105	53	105	K20	4.6
- 135		135		105		4.8
- 165		165		105		5.0
MC32 - 105	32	105	74	110	K32	5.5
- 135		135		125		5.8
- 165		165		125		6.5
MC42 - 105	42	105	94	120	K42	5.9
- 135		135		130		6.5
- 165		165		135		7.8

- ▶ 고속 바란스 작업시 추가 비용이 청구됩니다.
- ▶ 밀링척은 콜릿을 사용하여 다양한 Shank의 공구들을 체결할 수 있습니다.
- ▶ 밀링척 전용 콜릿은 P140~P143
- ▶ 밀링척 스페너는 별도 판매품 입니다. P157

- ▶ Extra charge for high speed balance.
- ▶ MILLING CHUCK is possible to use cutting tools of a various shank with COLLET.
- ▶ K-COLLET are referred. P140~P143
- ▶ Spanner is ordered separately. P157

SHRINK FIT HOLDER

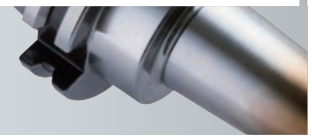

Coolant-through hole
Clamping Range : $\phi 3.0 \sim \phi 20.0$

CODE No.

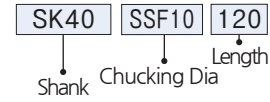

MAX
25,000
min⁻¹

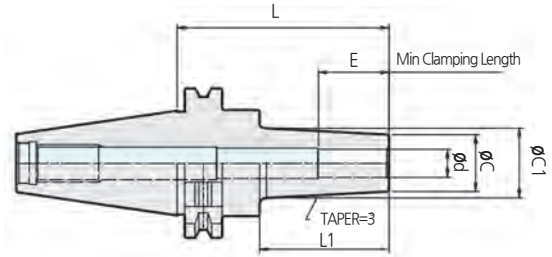

PRODUCT INFORMATION

- 4D선단에서 3 μ m이내의 흔들림 정도
- 높은 정밀도와 강력한 파지력
- 대칭적, 슬림한 디자인으로 가공최적화
- 전제품 내부급유 (Coolant Through Hole)
- 3 μ m(T.I.R) Run-out at 4D away from shank nose.
- Excellent Run-out accuracy and powerful clamping.
- Optimal operation with slim and symmetrical design.
- All products can be used for center through coolant type.

Code No.	ϕd	ϕC	$\phi C1$	L	L1	E	Weight (kg)
SK40 - SSF 4 - 90	4	10	26	90	37	12	1.0
SSF 6 - 90			20		60		1.1
- 160	6	14	21	160	130	18	1.2
SSF 8 - 90			24		60		1.2
- 160	8	18	32	160	130	24	1.4
SSF10 - 90			28		60		1.2
-160	10	22	36	160	130	30	1.4
SSF12 - 90			30		60		1.3
- 160	12	24	38	160	130	30	1.5
SSF16 - 90			34		60		1.4
- 160	16	28	42	160	130	34	1.6
SSF20 - 90			40		60		1.5
- 160	20	34	48	160	130	40	1.8
SK50 - SSF 6 - 100			20		100		59
- 160	6	14	26	160	119	18	4.2
SSF 8 - 100			24		100		59
- 160	8	18	30	160	119	24	4.3
SSF10 - 100			28		100		59
- 160	10	22	34	160	119	30	4.5
SSF12 - 100			30		100		59
- 160	12	24	36	160	119	30	4.6
SSF16 - 100			34		100		59
- 160	16	28	40	160	119	34	4.8
SSF20 - 100			46		100		59
-160	20	34	53	160	119	40	5.0

- ▶ 열박음홀더 사용시 절삭공구 Shank경은 h6의 제품을 사용해 주십시오.
- ▶ 절삭공구는 초경 Shank만 대응합니다. (하이스 제품 사용금지)
- ▶ 열박음홀더 사용시 지정된 고주파 히팅기를 사용해서 절삭공구 체결을 권장합니다.
- ▶ SELUX 고주파 히팅기는 P153
- ▶ 절삭공구 최소 삽입길이를 준수해 주시기 바랍니다.
- ▶ 공구길이조정 Stopper는 별도 판매입니다. P153
- ▶ 열박음홀더 사용시 오일홀 풀스터드 볼트를 권장합니다.
- ▶ 열박음척 사용시 척 내경에 있는 방청유를 제거후에 사용하셔야 합니다. 내구성 저하 원인이 됩니다.

- ▶ Please use only carbide cutting tools of a shank tolerance within H6.
- ▶ Please use only carbide cutting tools for shrink fit holder. (Prohibit use HSS CUTTING TOOLS)
- ▶ We recommend shrink fit equipment when you use shrink fit holder.
- ▶ SELUX shrink fit equipment is referred. P153
- ▶ Please follow minimum insertion length of the cutting tools.
- ▶ Stopper for adjusting cutting tool length order separately. P153
- ▶ We recommend oil hole Pull stud bolt for shrink fit holder.
- ▶ Please clean the shank outside and inside of shrink fit before use. If you don't clean the shrink fit, it has problem about Run-out and tool life.

SK SHANK SHRINK FIT HOLDER

SSK COLLET CHUCK



Coolant-through hole
Clamping Range : $\phi 1.0 \sim \phi 25.4$

CODE No.

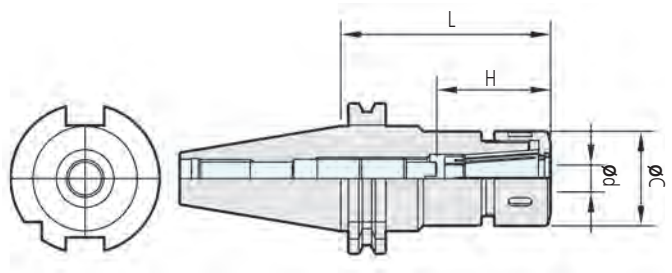
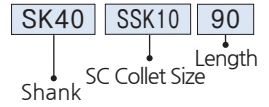

PRODUCT INFORMATION

- 8. Taper 의 강력한 파지력
- 높은 정밀도와 빠른 가공에 적합
- 드릴, 센터드릴, 엔드밀, 탭, 리머용으로 사용
- Powerful clamping force of 8. taper.
- Excellent Run-out Accuracy.
- SSK COLLET CHUCK is suitable for a various operation using drill, endmill, tap and reamer.

Code No.	ϕd	L	ϕC	H		Collet	Weight (kg)
				Min	Max		
SK40 - SSK 6 - 60	0.9~6.0	60	19.5	19	34	SC6	1.0
- 90		90					1.1
- 120		120					1.2
SSK10 - 60	1.75~10.0	60	27.5	30	50	SC10	1.2
- 90		90					1.5
- 120		120					1.8
- 150		150					2.0
SSK13 - 75	2.75~13.0	75	33	36	60	SC13	1.9
- 90		90					1.4
- 120		120					1.8
- 150		150					2.1
SSK16 - 75	2.75~16.0	75	40	45	70	SC16	1.3
- 90		90					1.4
- 120		120					1.8
- 150		150					2.1
SSK20 - 90	3.6~20.0	90	48	50	75	SC20	1.4
- 120		120					2.0
- 150		150					2.5
SSK25 - 90	15.6~25.4	90	55	55	85	SC25	1.4
- 120		120					2.0
- 150		150					2.5
SK50 - SSK 6 - 105	0.9~6.0	105	19.5	21	32	SC6	3.8
- 135		135					4.0
- 165		165					4.2
SSK10 - 105	1.75~10.0	105	27.5	30	50	SC10	3.9
- 135		135					4.3
- 165		165					4.6
SSK13 - 105	2.75~13.0	105	33	36	60	SC13	4.0
- 135		135					4.4
- 165		165					4.6
SSK16 - 105	2.75~16.0	105	40	40	70	SC16	4.2
- 135		135					4.6
- 165		165					4.8
- 165		165					4.8
SSK20 - 105	3.6~20.0	105	48	50	75	SC20	4.5
- 135		135					4.7
- 165		165					4.9
SSK25 - 105	15.6~25.4	105	55	55	85	SC25	4.6
- 135		135					4.8
- 165		165					5.0

SK SHANK SSK COLLET CHUCK

ER COLLET CHUCK



Coolant-through hole
Clamping Range : $\phi 0.5 \sim \phi 26.0$

CODE No.
SK50 ER32 105
Shank ER Collet Size Length

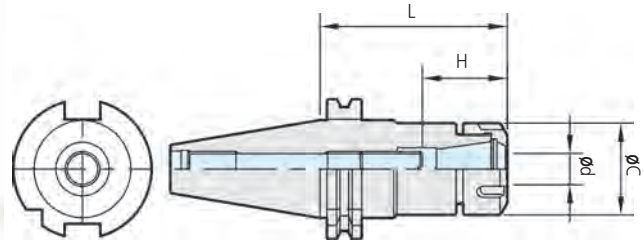

PRODUCT INFORMATION

머시닝 센터의 기본 홀더입니다.

- 나사연마
- 공구 착탈이 용이
- Balanced/balanceable type도 주문 제작합니다.
- Coolant through type 사용할 경우
 1. 방수형 Collet나 방수형 Nut을 사용
 2. Adjustable screw를 Coolant through type으로 교환.

Basic Holder of Machining Center

- Thread grinded.
- Convenient tool change.(chucking/unchucking)
- Balanced and balanceable type can be ordered.
- In case of using coolant through type.
 1. Must be using coolant through type collet and nut.
 2. Replacing coolant through type adjustable screw.

Code No.	ϕd	L	ϕC	H		Collet	Weight (kg)
				Min	Max		
SK40 - ER11 - 60	0.5~7.0	60	19	19	34	ER11	0.8
- 90		90					1.1
- 120		120					1.2
ER16 - 60	0.5~10.0	60	28	23	43	ER16	1.0
- 90		90					1.2
- 120		120					1.4
- 150		150					1.8
ER20 - 75	1.0~13.0	75	35	25	48	ER20	1.0
- 90		90					1.2
- 120		120					1.4
- 150		150					1.8
ER25 - 75	1.0~16.0	75	42	34	54	ER25	1.0
- 90		90					1.2
- 120		120					1.6
- 150		150					1.9
ER32 - 90	2.0~20.0	90	50	40	60	ER32	1.4
- 120		120					1.8
- 150		150					2.1
ER40 - 90	3.0~26.0	90	63	50	80	ER40	1.6
- 120		120					1.9
- 150		150					2.2
SK50 - ER11 - 75	0.5~7.0	75	19	19	34	ER11	3.5
- 105		105					3.7
- 135		135					3.9
ER16 - 75	0.5~10.0	75	28	23	43	ER16	3.6
- 105		105					3.8
- 135		135					4.1
- 165		165					4.3
ER20 - 75	1.0~13.0	75	35	25	48	ER20	3.6
- 105		105					3.8
- 135		135					4.1
- 165		165					4.2
ER25 - 75	1.0~16.0	75	42	34	54	ER25	3.7
- 105		105					3.9
- 135		135					4.1
- 165		165					4.4
ER32 - 90	2.0~20.0	90	50	40	60	ER32	3.9
- 105		105					4.3
- 135		135					4.9
- 165		165					5.0
ER40 - 90	3.0~26.0	90	63	50	80	ER40	4.0
- 105		105					4.6
- 135		135					5.2
- 165		165					6.0

SK SHANK

ER COLLET CHUCK

NC DRILL CHUCK

Clamping Range : $\varnothing 0.5 \sim \varnothing 13.0$



CODE No.

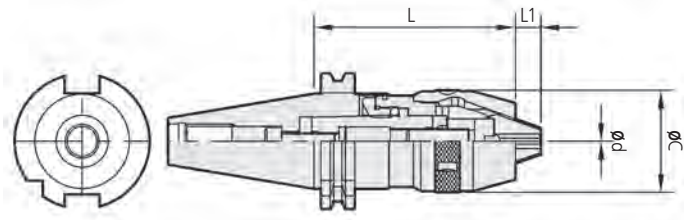
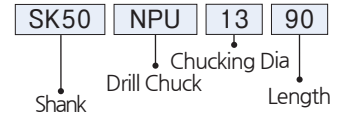

PRODUCT INFORMATION

머시닝 센터의 일반적인 드릴링 공구입니다. **General Drillings for Machining Centers**

- 척과 샹크가 일체형 구조로 길이가 짧음
- 가공정도 향상과 우수한 내구성
- 척의 탈락이 없고 주축 정지시 풀리지 않음
- Unified body of chuck and shank reduces the length of tool.
- Improved operation accuracy and excellent rigidity
- The drillchuck is never detached from holder and is not released when the operation is stop.

Code No.	$\varnothing d$	L	$\varnothing C$	L1	Weight (kg)
SK40 - NPU 8 - 80	0.3~8.0	80	36	8.5	2.0
- 105		105			2.4
NPU 13 - 105	1.0~13.0	105	48	11.5	2.4
- 130		130			2.8
- 175		175			3.3
SK50 - NPU 8 - 80	0.3~8.0	80	36	8.5	5.0
- 105		105			5.8
- 170		170			6.5
NPU 13 - 90	1.0~13.0	90	48	11.5	5.6
- 130		130			7.0
- 190		190			7.8

- ▶ 초경 드릴, 탭은 절대 사용을 금지해 주십시오.
- ▶ 절삭공구 최소 척킹 길이를 준수해 주시기 바랍니다.
NPU8-20mm이상
NPU13-30mm이상
- ▶ 스페너는 별매입니다. **P157**
- ▶ Please Prohibit use CARBIDE DRILL and CARBIDE TAP.
- ▶ Please follow minimum length of cutting tools.
NPU8 : more 20mm
NPU13 : more 30mm
- ▶ Spanner is ordered separately. **P157**

Runout Accuracy

- ▶ 0.040 이하의 흔들림 정도.
- ▶ 40 μ m (T.I.R)Runout at 3.5D Away form shank nose.

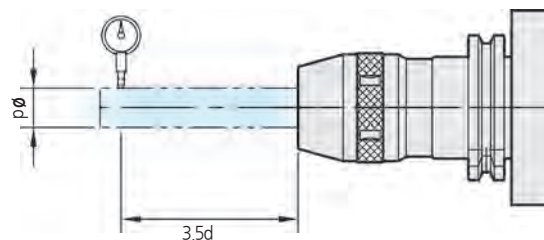

TAPPING CHUCK HOLDER



Tapping Range : M3 ~ M36

CODE No.

SK50 | TCH22 | 165
 ↓ MAX Tapping Length
 Shank

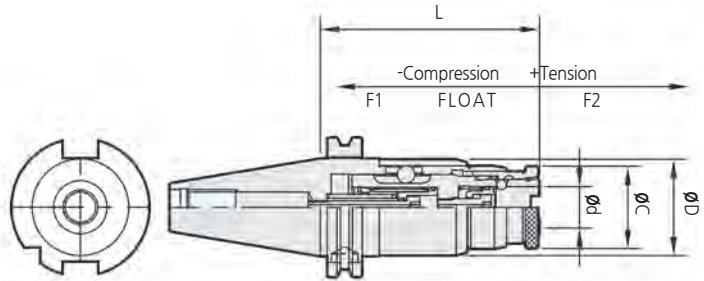

PRODUCT INFORMATION

- 플로팅 타입으로 인장수축 장치 내장
- 공구교환이 빠르고 편리함
- 관통구멍과 막힌구멍의 tapping 및 모든 tap 작업 가능
- The tapping chuck is equipped with tension system by floating type.
- Easy and quick tool exchange.
- It is possible for tapping operation of blind hole and through hole.

Code No.	ød	øD	L	øC	Float		Weight (kg)
					F1	F2	
SK40 - TCH12 - 120	19	44	95	35	6	12	1.8
TCH22 - 165	31	61	132	52	10	15	3.0
SK50 - TCH12 - 135	19	44	110	35	6	12	4.4
- 165			140				4.7
TCH22 - 165	31	61	132	52	10	15	5.0
- 195			162				5.5
TCH36 - 240	48	88	192	83	15	20	8.2

▶ 적용 탭콜릿은 P149 ▶ Private tap collets are referred. P149

JACOBS TAPER ARBOR

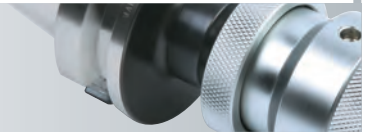

CODE No.

SK50 | JTA6 | 45
 ↓ Jacobs No. Length
 Shank

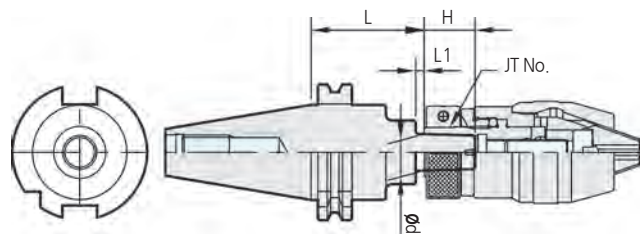

PRODUCT INFORMATION

- Drill chuck은 포함되어 있지 않습니다.
- Drill chuck is not included.

Code No.	ød	JT No.	L	L1	H	Weight (kg)
SK40 - JTA2 - 45	14.119	2	45	4	20	1.1
- 90			90			1.4
JTA6 - 45	17.170	6	45	4	24	1.1
- 90			90			1.4
SK50 - JTA2 - 45	14.119	2	45	4	20	4.0
- 105			105			4.4
JTA6 - 45	17.170	6	45	4	24	4.0
- 105			105			4.4

SK SHANK TAPPING CHUCK HOLDER / JACOBS TAPER ARBOR

SIDE LOCK HOLDER



Coolant-through hole
Clamping Range : $\phi 6.0 \sim \phi 42.0$

CODE No.

SK50	SLA32	105
------	-------	-----

 ↓ Chucking Dia Length
 Shank



TAPER 접촉을 80% 이상 진동없음.

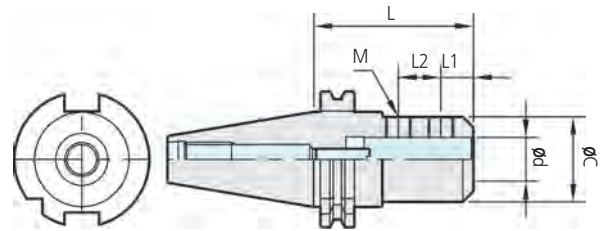

PRODUCT INFORMATION

- 각종 드릴, 엔드밀, 기타 스페셜 공구를 끼워 사용.
- 연결하여 사용 가능한 공구
 1. ST-ER, ST-SSK, ST-FMA(FMC), ST-SCA 등
 2. ST-TCH
- Special도 제작가능 합니다. (flange type)
- Side lock holder can be using as a tool holder. (drill, endmill, special tool, etc)
- The following tools to suit side lock holder are available.
 1. Straight collet chuck shank.
 2. Straight tapping chuck shank.
- Special type can be ordered. (flange type)

Code No.	ϕd	L	ϕC	L1	L2	M	Weight (kg)
SK40 - SLA 6 - 75	6	75	25	18	-	M 6	1.1
SLA 8 - 75	8		28			M 8	1.1
SLA10 - 75	10		35			M10	1.2
SLA12 - 75	12		40			M12	1.4
SLA16 - 75	16		45			M14	1.5
SLA20 - 75	20		48			M16	1.8
SLA25 - 105	25	105	48	24	25	M18	1.9
SLA32 - 105	32		62		28	M20	2.0
SK50 - SLA 6 - 90	6	90	25	18	-	M 6	3.7
SLA 8 - 90	8		28			M 8	3.9
SLA10 - 90	10		35			M10	4.0
SLA12 - 90	12		42			M12	4.1
SLA16 - 90	16		48			M14	4.3
SLA20 - 90	20		48			M16	4.5
- 105		105		24	25	M18	4.8
SLA25 - 105	25		48			4.8	
SLA32 - 105	32		62			4.8	
SLA40 - 105	40		76			4.9	
SLA42 - 105	42		80		28	M20	5.0

▶ 사이드락홀더 스페어 파트는 P64

▶ The spare parts for SIDE LOCK HOLDER are referred. P64

PRO MILL ARBOR



CODE No.

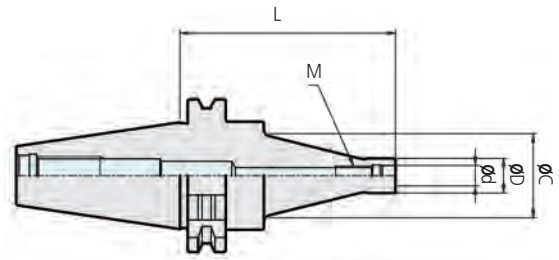
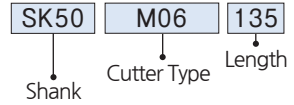

PRODUCT INFORMATION

- 모듈라 방식으로 원가 절감
- 높은 정밀도
- 이면구속 체결로 흔들림 감소
- 헤드 교체로 다양한 작업가능
- Cost reduction effect with modular system.
- Excellent accuracy.
- Vibration damping effect due to dual face contact.
- A various operation with exchanging head.

Code No.	ød	L	øD	øC	M	Weight (kg)
SK40 - M06 - 90	6.5	90	10	40	M6	1.2
- 120		120				1.5
M08 - 90	8.5	90	14.4		M8	1.2
- 120		120				1.5
M10 - 90	10.5	90	18		M10	1.3
- 120		120				1.5
- 150		150				1.9
M12 - 120	12.5	120	22.5		M12	1.5
- 150		150		1.9		
SK50 - M06 - 135	6.5	135	10	65	M6	4.2
- 165		165				4.9
M08 - 135	8.5	135	14.4		M8	4.2
- 165		165				4.9
M10 - 135	10.5	135	18		M10	4.2
- 165		165				4.9
M12 - 135	12.5	135	22.5		M12	4.2
- 165		165				4.9

PRO MILL CUTTER(Ball Type)

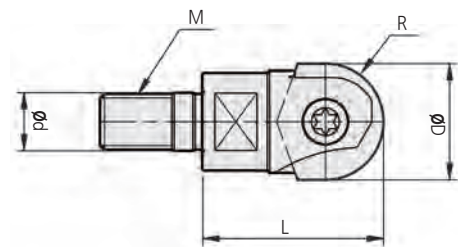

PRODUCT INFORMATION

- HITACHI 인서트 호환
- 경삭 R작업 최적화
- Compatible with HITACHI insert.
- Optimal for R-finishing operation.

Code No.	R	øD	L	ød	M	Insert	Screw	Wrench
R05M0630	5	10	30	6.5	M6	ZPFG100, ZCFW100	TNS-5842	TXL-10
R06M0630	6	12				ZPFG120, ZCFW120	TNS-5843	TXT-20
R08M0830	8	16		8.5	M8	ZPFG160, ZCFW160	TNS-5844	
R10M1035	10	20	35	10.5	M10	ZPFG200, ZCFW200	TNS-5845	TXT-25
R12M1240	12.5	25	40	12.5	M12	ZPFG250, ZCFW250	TNS-5846	TXT-30

▶ 다양한 Type의 컷터 제작가능합니다.
▶ 전용 spanner는 별매.

▶ Cutters can be made of a variety of Type.
▶ Spanner is orderd seperately.

MORES TAPER HOLDER

☑ For morse taper shank with tang



CODE No.

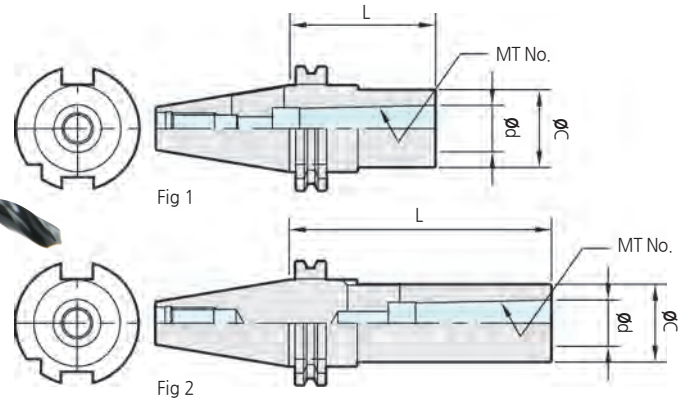
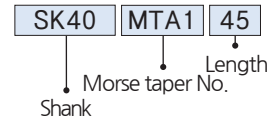

TAPER 접촉을 80% 이상 진동없음.

PRODUCT INFORMATION

■ Drill, reamer, 기타(MT Shank type tool)등을 사용 할 수 있습니다.

■ MORSE TAPER HOLDER can use tool holder for drill, reamer, etc.

Code No.	ød	MT No.	L	øC	Fig	Weight (kg)
SK40 - MTA1 - 45	12.065	1	45	25	1	1.1
- 120			120		2	1.3
MTA2 - 60	17.780	2	60	32	1	1.1
- 120			120		2	1.4
MTA3 - 75	23.825	3	75	40	1	1.2
- 135			135		2	1.7
MTA4 - 95	31.267	4	95	50	1	1.4
- 165			165		2	2.4
SK50 - MTA1 - 45	12.065	1	45	25	1	3.9
- 120			120		2	4.2
- 180			180			4.3
MTA2 - 45	17.780	2	45	32	1	3.9
- 135			135		2	4.3
- 180			180			4.6
MTA3 - 45	23.825	3	45	40	1	3.8
- 150			150		2	4.6
- 180			180			4.9
MTA4 - 75	31.267	4	75	50	1	3.9
- 180			180		2	5.4
MTA5 - 105	44.399	5	105	65	1	4.5
- 210			210		2	7.2

Drill Dia and Shank

Shank		MT1	MT2	MT3	MT4	MT5
Drill dia	Min	3.0	14.5	23.5	32.0	51.0
	Max	14.0	23.0	31.5	50.0	76.0

FACE MILL ARBOR

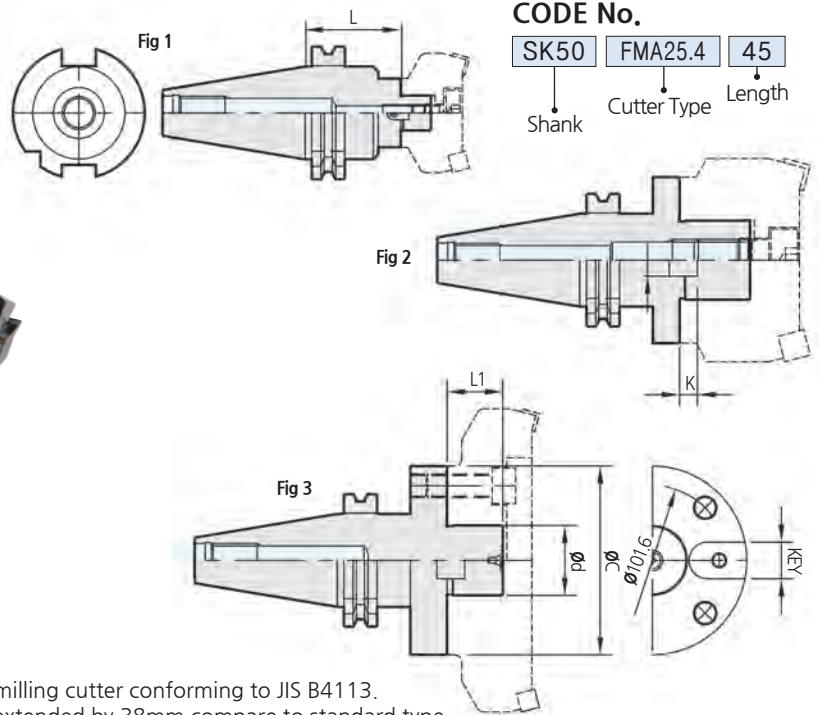

CODE No.

SK50 FMA25.4 45
 Shank Cutter Type Length

PRODUCT INFORMATION

- JIS B4113 face milling용 입니다.
- For face-milling cutter conforming to JIS B4113.
- (S)Type은 표준길이(+38mm)
- S type is extended by 38mm compare to standard type.

FMA Type

Code No.	ød	Cutter Dia	L	øC	L1	Key	K	Fig	Weight (kg)
SK40 - FMA25.4 - 45	25.4	80	45	50	22	K9.5-L	5	1	1.5
- 90			90						2.2
FMA31.75 - 45	31.75	100	45	60	30	K12.7-L	7	1	1.6
- 75			75						2.3
FMA38.1 - 60	38.1	125	60	80	34	K15.87-L	9	2	2.9
SK50 - FMA25.4 - 45	25.4	80	45	50	22	K9.5-L	5	1	3.8
- 90			90						4.5
-150			150						5.5
FMA31.75 - 45	31.75	100	45	60	30	K12.7-L	7	1	4.6
- 75			75						5.2
-105			105						6.0
FMA38.1 - 45	38.1	125	45	80	34	K15.87-L	9	2	4.3
- 75			75						5.5
FMA50.8 - 45	50.8	160	45	100	36	K19.05-L	10	2	4.8
- 75			75						6.8
FMA47.625 - 75	47.625	200	75	128	38	K25.4	12.5	3	7.6

FMC Type

Code No.	ød	Cutter Dia	L	øC	L1	Key	K	Fig	Weight (kg)
SK40 - FMC22 - 45	22	50/63	45	45	18	K10-L	5.5	1	1.9
FMC27 - 50	27	63/80	50	60	20	K12-L	6	2	2.0
FMC32 - 60	32	100	60	85	22	K14-L	7		2.2
SK50 - FMC22 - 50	22	50/63	50	45	18	K10-L	5.5	1	3.6
FMC27 - 60	27	63/80	60	60	20	K12-L	6		4.1
FMC32 - 60	32	100		85	22	K14-L	7	2	5.5

▶ 페이스밀아바 스페어 파트는 P75

▶ The spare parts for FACE MILL ARBOR are referred. P75

Excellent Precision
Excellent Quality

SELUX
NC TOOLING SYSTEM

NT/MT

CHUCK & Item

NT MILLING CHUCK
MILLING CHUCK SET (NT TYPE)
MT MILLING CHUCK (TANG)
MT MILLING CHUCK (SCREW)
ER COLLET CHUCK
MT ER COLLET CHUCK(TANG)
MT ER COLLET CHUCK(SCREW)
MT SIDE LOCK HOLDER (TANG)
FACE MILL ARBOR



NT MILLING CHUCK



Clamping Range : $\phi 3.0 \sim \phi 42.0$

CODE No.

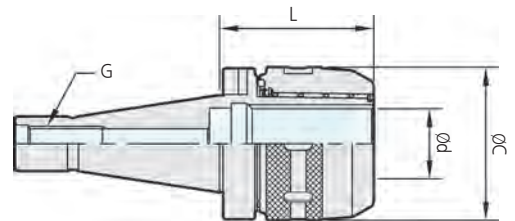
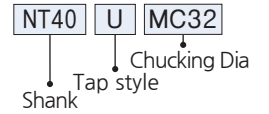

PRODUCT INFORMATION

- 간편한 척킹 시스템
- 완전한 단면 밀착으로 강력 절삭
- 4배열 Roller System 방식으로 강력한 파지력
- Easy chucking system.
- The strongest cutting power due to perfect face contact construction.
- Powerful clamping force by 4 needle roller system.

Code No.	φC	L	φd	G		Collet	Weight (kg)
				UNC	M		
NT30U(M) - MC20	53	70	20	U1/2-13	M12	K20	1.6
- MC25	62	75	25			K25	1.8
- MC32	72	95	32			K32	2.0
NT40U(M) - MC20	53	70	20	U5/8-11	M16	K20	2.2
- MC25	62	70	25			K25	2.4
- MC32	72	75	32			K32	2.9
NT50U(M) - MC25	62	70	25	U1"-8	M24	K25	5.0
- MC32	72	90	32			K32	5.5
- MC42	94	90	42			K42	6.0

- ▶ 밀링척은 콜릿을 사용하여 다양한 Shank의 공구들을 체결할 수 있습니다.
- ▶ 밀링척 전용 콜릿은 P140~P143
- ▶ 밀링척 스패너는 별도 판매품 입니다. P157
- ▶ MILLING CHUCK is possible to use cutting tools of a various shank with COLLET.
- ▶ K-COLLET are referred. P140~P143
- ▶ Spanner is ordered separately. P157

NT/MT SHANK
NT MILLING CHUCK

MILLING CHUCK SET (NT TYPE)



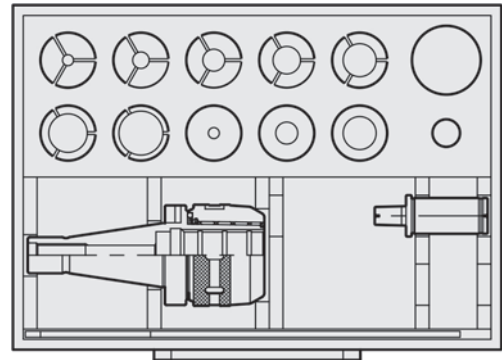
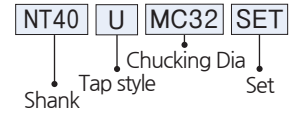

Clamping Range : $\phi 3.0 \sim \phi 42.0$

CODE No.

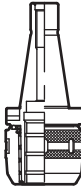

PRODUCT INFORMATION

- 간편한 척킹 시스템
- 완전한 단면 밀착으로 강력 절삭
- 4배열 Roller System 방식으로 강력한 파지력
- Easy chucking system.
- The strongest cutting power due to perfect face contact construction.
- Powerful clamping force by 4 needle roller system.

Code No.	SET CONTENTS				
	Body	K-Collet	MT Collet	JT Collet	Spanner
					
NT40U - MC20,SET	NT40U - MC20	K20 - 6,8,10,12,16	K20 - MT1,MT2	K20 - JT6	MC20 - SP
- MC25,SET	NT40U - MC25	K25 - 6,8,10,12,16,20	K25 - MT1,MT2	K25 - JT6	MC25 - SP
- MC32,SET	NT40U - MC32	K32 - 6, 8, 10, 12,16,20,25	K32 - MT1,MT2,MT3	K32 - JT6	MC32 - SP
NT50U - MC32,SET	NT50U - MC32	K32 - 6, 8, 10, 12,16,20,25	K32 - MT1,MT2,MT3	K32 - JT6	MC32 - SP
- MC42,SET	NT50U - MC42	K42 - 6,8,10,12,16, 20, 25, 32	K42 - MT1,MT2,MT3,MT4	K42 - JT6	MC42 - SP

▶ 포장용 나무케이스는 별도로 판매하지 않습니다.

▶ You can not order only wooden case for set.

MT MILLING CHUCK (TANG)



Clamping Range : $\phi 3.0 \sim \phi 42.0$

CODE No.

MT6T MC32
 ↓ Chucking Dia
 Shank

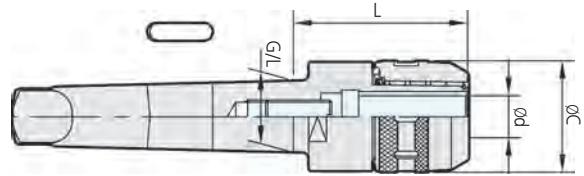

PRODUCT INFORMATION

- 간편한 척킹 시스템
- 완전한 단면 밀착으로 강력 절삭
- 4배열 Roller System 방식으로 강력한 파악력

- Easy chucking system.
- The strongest cutting power due to perfect face contact construction.
- Powerful clamping force by 4 needle roller system.

Code No.	ϕd	G/L	L	ϕC	Collet
MT4T - MC20(I)	20	31.267	80	53	K20, NC20
- MC32(T)	32		100	72	K32, NC32
MT5T - MC32(I)	32	44.399	90	74	K32, NC32
- MC32(T)					
- MC32(D)					
MT6T - MC42(I)	42	63.348	98	94	K42, NC42
- MC42(T)					
- MC42(D)					
- MC42(W)					

▶ Special size도 주문 제작합니다.
 ▶ 주문시 장비에 cotter pin 사양을 꼭 확인해서
 주문 해 주십시오. P164

▶ Special size can be ordered.
 ▶ Cotter pin size check. P164

MT MILLING CHUCK (SCREW)



Clamping Range : $\phi 3.0 \sim \phi 32.0$

CODE No.

MT5S MC20
 ↓ Chucking Dia
 Shank

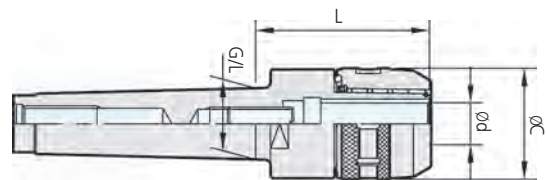

PRODUCT INFORMATION

- 간편한 척킹 시스템
- 완전한 단면 밀착으로 강력 절삭
- 4배열 Roller System 방식으로 강력한 파악력

- Easy chucking system.
- The strongest cutting power due to perfect face contact construction.
- Powerful clamping force by 4 needle roller system.

Code No.	ϕd	G/L	L	ϕC	Collet
MT3S - MC20	20	23.825	85	53	K20, NC20
MT4S - MC20	32	31.267	80	72	K32, NC32
- MC32			90	53	K20, NC20
MT5S - MC20	20	44.399	80	74	K32, NC32
- MC32	32		90		

▶ Special size도 주문 제작합니다.

▶ Special size can be ordered.

ER COLLET CHUCK

Clamping Range : $\varnothing 0.5 \sim \varnothing 26.0$

CODE No.

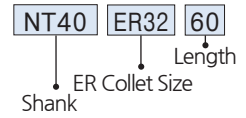

레디알 밀링에서 작업가능!!

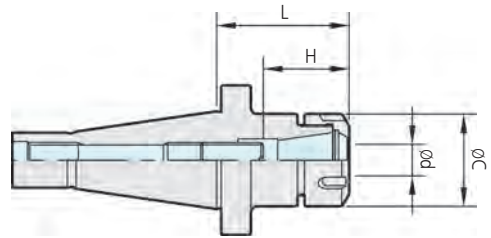

PRODUCT INFORMATION

- 안정적인 정밀도와 파지력
- Reliably accuracy and Powerful clamping force.
- 쉽고빠른 공구교환
- Easy and quick tool exchange.
- 드릴, 엔드밀, 탭 다양한 사용범위
- ER COLLET CHUCK is suitable for a various operation using drill, endmill, tap.

Code No.	$\varnothing d$	L	$\varnothing C$	H		Collet
				Min	Max	
NT40U - ER16 - 40	0.5~10.0	40	28	23	43	ER16
ER20 - 40	1.0~13.0		35	25	48	ER20
ER25 - 50	1.0~16.0	50	42	34	54	ER25
ER32 - 60	2.0~20.0	60	50	40	60	ER32
ER40 - 80	3.0~26.0	80	63	50	80	ER40
NT50U - ER16 - 40	0.5~10.0	40	28	23	43	ER16
ER20 - 40	1.0~13.0		35	25	18	ER20
ER25 - 50	1.0~16.0	50	42	34	54	ER25
ER32 - 60	2.0~20.0	60	50	40	60	ER32
ER40 - 60	3.0~26.0		63	50	80	ER40

- ▶ ER콜릿은 P146
- ▶ 스패너는 별매입니다. P157
- ▶ ER척 스페어 파트는 P56
- ▶ ER COLLET is refered. P16
- ▶ Spanner is ordered separately. P157
- ▶ The spare parts for ER CHCUK are refered. P56

MT ER COLLET CHUCK (TANG)



Clamping Range : $\varnothing 0.5 \sim \varnothing 26.0$



CODE No.

MT5 T ER32 60
 Shank Tang ER Collet Size Length

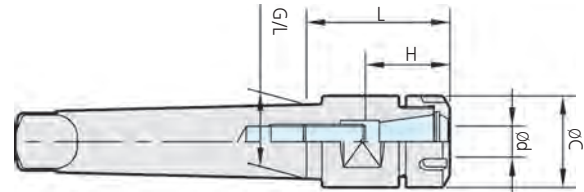

PRODUCT INFORMATION

- 안정적인 정밀도와 파지력
- Reliable accuracy and Powerful clamping force.
- 쉽고빠른 공구교환
- Easy and quick tool exchange.
- 드릴, 엔드밀, 탭 다양한 사용범위
- ER COLLET CHUCK is suitable for a various operation using drill, endmill, tap.

Code No.	$\varnothing d$	L	$\varnothing C$	H		Collet	Weight (kg)
				Min	Max		
MT1T - ER11 - 40	0.5 ~ 7.0	40	19	19	34	ER11	0.3
MT2T - ER11 - 40	0.5 ~ 7.0	40	19	19	34	ER11	0.4
ER16 - 50	0.5 ~ 10.0	50	28	23	43	ER16	0.4
MT3T - ER16 - 40	0.5 ~ 10.0	40	28	19	43	ER16	0.5
ER20 - 50	1.0 ~ 13.0	50	35	25	48	ER20	0.5
MT4T - ER16 - 40	0.5 ~ 10.0	40	28	23	43	ER16	0.9
ER20 - 55	1.0 ~ 13.0	55	35	25	48	ER20	1.0
ER25 - 55	1.0 ~ 16.0		42	34	54	ER25	1.1
ER32 - 60	2.0 ~ 20.0	60	50	40	60	ER32	1.3
MT5T - ER20 - 50	1.0 ~ 13.0	60	35	25	48	ER20	2.0
ER25 - 60	1.0 ~ 16.0		42	34	54	ER25	2.1
ER32 - 60	2.0 ~ 20.0		50	40	60	ER32	2.2
ER40 - 70	3.0 ~ 26.0	70	63	50	80	ER40	2.4

- ▶ ER콜릿은 P146
- ▶ 스페너는 별매입니다. P157
- ▶ ER척 스페어 파트는 P56
- ▶ ER COLLET is referred. P146
- ▶ Spanner is ordered separately. P157
- ▶ The spare parts for ER CHCUK are referred. P56

MT ER COLLET CHUCK (SCREW)

Clamping Range : $\varnothing 0.5 \sim \varnothing 26.0$

CODE No.

MT5	S	ER20	50
Shank	Screw	ER Collet Size	Length

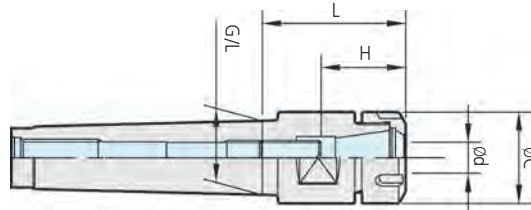

PRODUCT INFORMATION

- 안정적인 정밀도와 파지력
- Reliable accuracy and Powerful clamping force.
- 쉽고빠른 공구교환
- Easy and quick tool exchange.
- 드릴, 엔드밀, 탭 다양한 사용범위
- ER COLLET CHUCK is suitable for a various operation using drill, endmill, tap.

Code No.	$\varnothing d$	L	$\varnothing C$	H		Collet	Weight (kg)
				Min	Max		
MT1S - ER11 - 40	0.5 ~ 7.0	40	19	19	34	ER11	0.3
MT2S - ER11 - 40	0.5 ~ 7.0	40	19	19	34	ER11	0.4
ER16 - 50	0.5 ~ 10.0	50	28	23	43	ER16	0.4
MT3S - ER16 - 40	0.5 ~ 10.0	40	28	23	43	ER16	0.5
ER20 - 50	1.0 ~ 13.0	50	35	25	48	ER20	0.5
MT4S - ER16 - 40	0.5 ~ 10.0	40	28	23	43	ER16	0.9
ER20 - 55	1.0 ~ 13.0	55	35	25	48	ER20	1.0
ER25 - 55	1.0 ~ 16.0		42	34	54	ER25	1.1
ER32 - 60	2.0 ~ 20.0	60	50	40	60	ER32	1.3
MT5S - ER20 - 50	1.0 ~ 13.0	50	35	25	48	ER20	2.0
ER25 - 60	1.0 ~ 16.0	60	42	34	54	ER25	2.1
ER32 - 60	2.0 ~ 20.0		50	40	60	ER32	2.2
ER40 - 70	3.0 ~ 26.0	70	63	50	80	ER40	2.4

- ▶ ER콜릿은 P146
- ▶ 스페너는 별매했습니다. P157
- ▶ ER척 스페어 파트는 P56
- ▶ ER COLLET is referred. P146
- ▶ Spanner is ordered separately. P157
- ▶ The spare parts for ER CHCUK are referred. P56

NT/MT SHANK MT ER COLLET CHUCK (SCREW)

MT SIDE LOCK HOLDER (TANG)



Clamping Range : $\varnothing 20.0 \sim \varnothing 50.0$

CODE No.

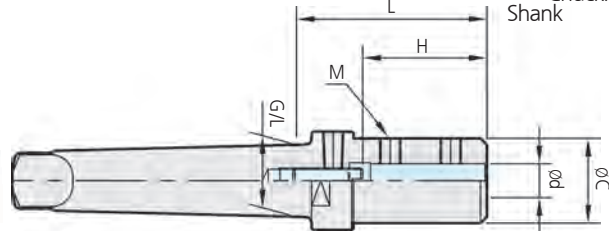
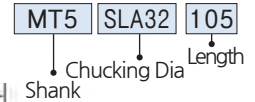

PRODUCT INFORMATION

■ 드릴, 엔드밀 기타(Small chuck, Special tool)을 사용할 수 있습니다.

■ SIDE LOCK HOLDER can use tool holder for drill, endmill, etc.

Code No.	$\varnothing d$	G/L	L	$\varnothing C$	H		M
					Min	Max	
MT4 - SLA20 - 90	20	31.267	90	50	60	75	M14
SLA25 - 90	25			52			
SLA32 - 105	32			65	80		
MT5 - SLA20 - 90	20	44.399	90	50	60	80	M14
SLA25 - 105	25			52			
SLA32 - 105	32			65	75		
SLA40 - 120	40	120	120	75	60	80	M18
SLA42 - 120	42			80			
MT6 - SLA25 - 105	25	63.348	105	52	65	75	M14
SLA32 - 105	32			65			M16
SLA40 - 120	40			75	50	80	M18
SLA42 - 120	42	80					
SLA50 - 120	50	90					

▶ 사이드락홀더 스페어 파트는 P64

▶ The spare parts for SIDE LOCK HOLDER are referred. P64

NT/MT SHANK

MT SIDE LOCK HOLDER (TANG) / NC DRILL CHUCK

NC DRILL CHUCK



Clamping Range : $\varnothing 0.5 \sim \varnothing 13.0$

CODE No.

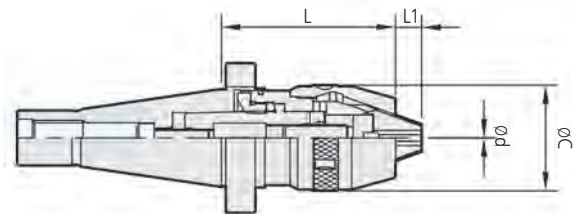
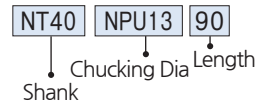

Code No.	$\varnothing d$	L	$\varnothing C$	L1	Weight (kg)
NT40U - NPU 8 - 70	0.3~8.0	70	38	8.5	1.4
NPU13 - 90	1.0~13.0	90	50	11.5	2.3
NT50U - NPU13 - 90	1.0~13.0	90	50	11.5	4.3

- ▶ 초경 드릴, 탭은 절대 사용을 금지해 주십시오.
- ▶ 절삭공구 최소 척킹 길이를 준수해 주시기 바랍니다.
NPU8-20mm이상
NPU13-30mm이상
- ▶ 스페너는 별매입니다. P157

- ▶ Please Prohibit use CARBIDE DRILL and CARBIDE TAP.
- ▶ Please follow minimum length of cutting tools.
NPU8 : more 20mm.
NPU13 : more 30mm.
- ▶ Spanner is ordered separately. P157

FACE MILL ARBOR

CODE No.

NT40 U FMA25.4
 ↓ Tap style ↓ Cutter Type
 Shank

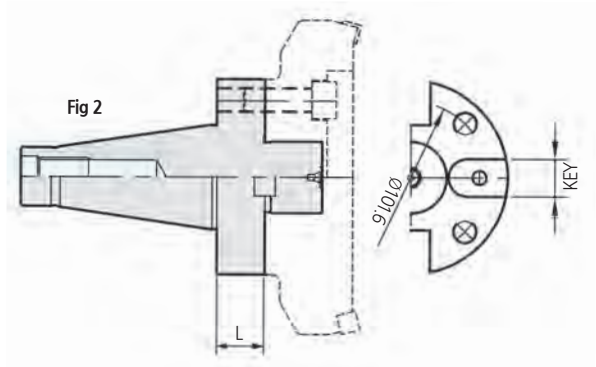
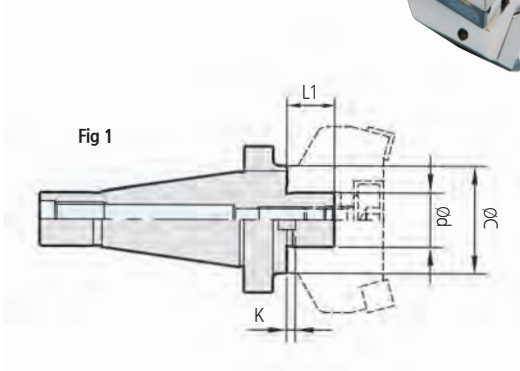

PRODUCT INFORMATION

■ JIS B4113 Face Milling용 입니다. ■ For face-milling cutter conforming to JIS B4113.

Code No.	ød	Cutter Dia	L	øC	L1	Key	K	Fig	Weight (kg)
NT40U - FMA25.4 (3R)	25.4	80	25	50	22	K9.5-S	5	1	1.2
FMA31.75 (4R)	31.75	100		60	30	K12.7-S	7	1	1.4
FMA38.1 (5R)	38.1	125		80	34	K15.87-S	9	1	2.0
FMA50.8 (6R)	50.8	160		98	36	K19-S	10	1	2.9
NT50U - FMA25.4 (3R)	25.4	80	30	50	22	K9.5-S	5	1	3.6
FMA31.75 (4R)	31.75	100		60	30	K12.7-S	7	1	4.0
FMA38.1 (5R)	38.1	125		80	34	K15.87-S	9	1	4.4
FMA50.8 (6R)	50.8	160		98	36	K19-S	10	1	4.6
FMA47.625(8R)	47.625	200		128	38	K25.4-S	12.5	2	6.0

▶ 페이스밀아바 스페어 파트는 P75

▶ The spare parts for FACE MILL ARBOR are referred. P75

MT FACE MILL ARBOR

CODE No.

MT5 T FMA25.4

Shank Tang Cutter Type

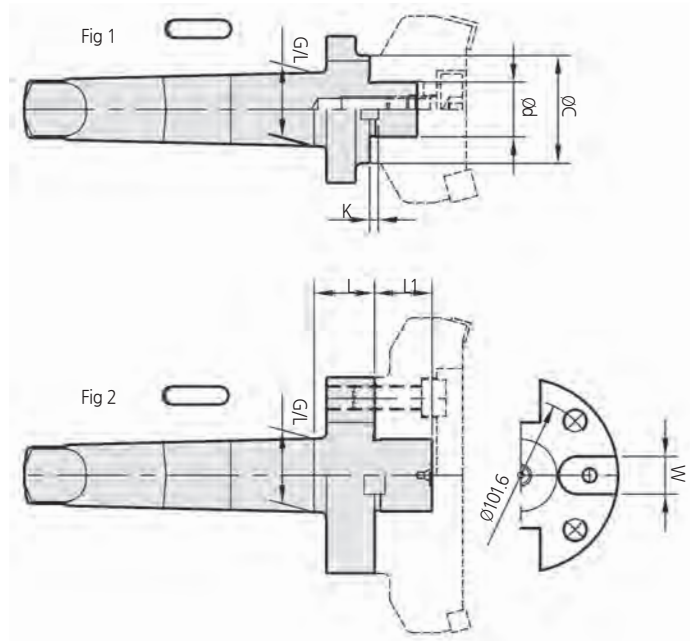

PRODUCT INFORMATION

- JIS B4113 Face Milling용 입니다.
- Cotter pin : 156page 참조.
- 대형 Endmill이나 Tapping등의 중절삭 가공시 추력의 발생으로 Tool의 빠짐을 Cotter pin을 박음으로 방지할 수 있음.
- 장비 업체에 따라 Cotter pin 구멍이 다르므로 기계 회사명 및 A, B, L 치수를 알려주십시오.

- For face-milling cutter conforming to JIS B4113.
- Cotter pin : see 156page.
- Mounting cotter pin can protect the tools drop, such as big endmill or tap due to occurring thrust in heavy duty.
- Cotter pin types are different according to machine manufacturer, please point out machine manufacturer and the size of "A,B", when you order.

Code No.	ød	Cutter Dia	L	øC	L1	Key	K	Fig
MT5T - FMA25.4 (3R)	25.4	80	30	50	22	K9.5 - L	5	1
FMA31.75 (4R)	31.75	100		60	30	K12.7 - L	7	
FMA38.1 (5R)	38.1	125		80	34	K15.87 - L	9	
FMA50.8 (6R)	50.8	160	45	98	36	K19 - L	10	1
MT6T - FMA25.4 (3R)	25.4	80	30	50	22	K9.5 - L	5	
FMA31.75 (4R)	31.75	100		60	30	K12.7 - L	7	
FMA38.1 (5R)	38.1	125		80	34	K15.87 - L	9	
FMA50.8 (6R)	50.8	160	45	98	36	K19 - L	10	
FMA47.625(8R)	47.625	200		128	38	K25.4	12.5	2

▶ 페이스밀아바 스페어 파트는 P75

▶ The spare parts for FACE MILL ARBOR are referred. P75

Excellent Precision
Excellent Quality

SELUX
NC TOOLING SYSTEM

ST

CHUCK & Item

- STRAIGHT SSK COLLET CHUCK (MILLING)
- STRAIGHT SSK COLLET CHUCK (CNC)
- SHRINK FIT HOLDER
- STRAIGHT ER COLLET CHUCK (MILLING)
- STRAIGHT ER COLLET CHUCK (CNC)
- STRAIGHT SLIM ER COLLET CHUCK (MILLING)
- GYRO CHUCK
- STRAIGHT NC DRILL CHUCK
- STRAIGHT TAPPING CHUCK
- FLOATING ER TAP CHUCK
- STRAIGHT FACE MILL ARBOR
- ST PRO MILL ARBOR (CARBIDE)
- ST PRO MILL CUTTER (BALL TYPE)



STRAIGHT SSK COLLET CHUCK (MILLING)

Coolant-through hole

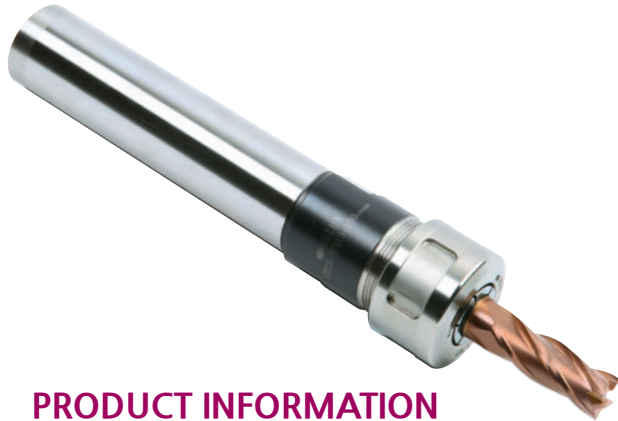
Clamping Range : $\phi 1.0 \sim \phi 25.4$ 

CODE No.

ST42 SSK16 165

Shank SC Collet Size Length

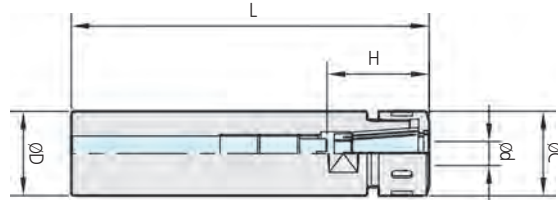

PRODUCT INFORMATION

- 8. Taper 의 강력한 파지력
- 높은 정밀도와 빠른 가공에 적합
- 드릴, 센터드릴, 엔드밀, 탭, 리머용으로 사용

- Powerful clamping force of 8. Taper.
- Excellent Run-out Accuracy.
- SSK COLLET CHUCK is suitable for a various operation using drill, endmill, tap and reamer.

Code No.	ϕd	ϕD	L	ϕC	H		Collet	Weight (kg)
					Min	Max		
ST20 - SSK 6 - 120	0.9~6.0	20	120	19.5	21	35	SC6	0.2
			180					0.4
SSK10 - 140	1.75~10.0	20	140	27.5	30	50	SC10	0.3
			200					0.5
SSK13 - 150	2.75~13.0	20	150	33	36	60	SC13	0.5
			180					0.6
			250					0.9
ST25 - SSK10 - 150	1.75~10.0	25	150	27.5	30	50	SC10	0.6
			210					0.9
SSK13 - 150	2.75~13.0	25	150	33	36	60	SC13	0.7
			210					0.9
SSK16 - 150	2.75~16.0	25	150	40	45	70	SC16	0.8
			200					1.0
ST32 - SSK10 - 150	1.75~10.0	32	150	27.5	30	50	SC10	0.7
			200					1.1
SSK13 - 150	2.75~13.0	32	150	33	36	60	SC13	0.9
			250					1.2
			280					1.8
SSK16 - 150	2.75~16.0	32	150	40	45	70	SC16	1.2
			220					1.5
SSK20 - 165	3.6~20.0	32	280	48	50	75	SC20	1.8
			165					2.0
ST42 - SSK16 - 180	2.75~16.0	42	180	40	45	70	SC16	1.4
			240					1.8
SSK20 - 180	3.6~20.0	42	180	48	50	75	SC20	1.6
			240					2.0
			280					2.3
			200					1.8
SSK25 - 200	15.6~25.4	42	200	55	55	85	SC25	1.8
			250					2.1
			300					2.5

- ▶ 너트, 조절나사 및 콜렛추출도구는 부속되어 있습니다.
- ▶ 스페너는 별매입니다. P157
- ▶ Synchronized Tap 사용시 SSK10을 사용하십시오.
Aluminum MAX Tapping M12
Steel MAX Tapping M10
Stainless Steel MAX Tapping M8
위 사양 이상인경우는 Milling Chuck에 K-Collet을 사용하시길 바랍니다.
- ▶ SSK척 콜렛은 P144~P145
- ▶ 절삭공구 체결시 무리한 힘이 가해질시 너트 및 홀더가 파손 될 수 있습니다.
- ▶ NUT, ADJUST SCREW, COLLET REMOVER are included.
- ▶ Spanner is ordered separately. P157
- ▶ Please use SSK10 when you use Synchronized Tap.
Aluminum MAX Tapping M12
Steel MAX Tapping M10
Stainless Steel MAX Tapping M8
If it has problem, We recommend K COLLET with Milling Chuck.
- ▶ SC COLLET is refered. P144 ~ P145
- ▶ The nut or shank of chuck can be destoried if you too strongly clamp nut and holder.

STRAIGHT SSK COLLET CHUCK (CNC)



Coolant-through hole
Clamping Range : $\phi 1.0 \sim \phi 16.0$



CODE No.
NC40 SSK16
 ↓ SC Collet Size
 Shank

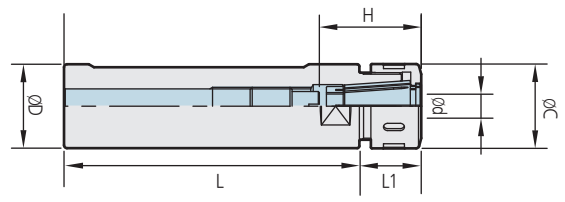

PRODUCT INFORMATION

- 8. Taper 의 강력한 파지력
- 높은 정밀도와 빠른 가공에 적합
- 드릴, 센터드릴, 엔드밀, 탭, 리머용으로 사용
- Powerful clamping force of 8. Taper.
- Excellent Run-out Accuracy.
- SSK COLLET CHUCK is suitable for a various operation using drill, endmill, tap and reamer.

Code No.	ϕd	ϕD	L	L1	ϕC	H		Collet	Weight (kg)
						Min	Max		
NC25 - SSK 6	0.9~6.0	25	68	20	19.5	21	35	SC 6	0.3
SSK10	1.75~10.0		67	22	27.5	30	50	SC10	0.3
NC32 - SSK10	1.75~10.0	32	72	22	27.5	30	50	SC10	0.7
SSK16	2.75~16.0		92	30	40	45	70	SC16	0.8
SSK20	3.6~20.0		72	59	48	50	75	SC20	0.9
NC40 - SSK10	1.75~10.0	40	75	22	27.5	30	50	SC10	1.1
SSK16	2.75~16.0		95	30	40	45	70	SC16	1.2
SSK20	3.6~20.0		93	33	48	50	75	SC20	1.2

Spare Parts				
Type	Basic		Option	
	Nut	Adjust Screw	Spanner	Collet
SSK 6	SCN- 6 (HEXA)	BTD0825-C	SC 6-SP	SC 6- ϕ
SSK10	SCN-10 (HEXA)	BTD1225-C	SC10-SP	SC10- ϕ
SSK13	SCN-13	BTD1525-C	SC13-SP	SC13- ϕ
SSK16	SCN-16	BTD1830-C	SC16-SP	SC16- ϕ
SSK20	SCN-20	BTD2230-C	SC20-SP	SC20- ϕ
SSK25	SCN-25	BTD2838-C	SC25-SP	SC25- ϕ

- ▶ 너트, 조절나사 및 콜릿추출도구는 부속되어 있습니다.
- ▶ 스패너는 별매입니다. P157
- ▶ Synchronized Tap 사용시 SSK10을 사용하십시오.
 Aluminum MAX Tapping M12
 Steel MAX Tapping M10
 Stainless Steel MAX Tapping M8
 위 사양 이상인 경우는 Milling Chuck에 K-Collet을 사용하시길 바랍니다.
- ▶ SSK적 콜릿은 P144~P145
- ▶ 절삭공구 체결시 무리한 힘이 가해질시 너트 및 홀더가 파손 될 수 있습니다.
- ▶ NUT, ADJUST SCREW, COLLET REMOVER are included.
- ▶ Spanner is ordered separately. P157
- ▶ Please use SSK10 when you use Synchronized Tap.
 Aluminum MAX Tapping M12
 Steel MAX Tapping M10
 Stainless Steel MAX Tapping M8
 If it has problem, We recommend K COLLET with Milling Chuck.
- ▶ SC COLLET is referred. P144 ~ P145
- ▶ The nut or shank of chuck can be destoried if you too strongly clamp nut and holder.

ST SHANK
STRAIGHT SSK COLLET CHUCK (CNC)

SHRINK FIT HOLDER

Coolant-through hole

Clamping Range : $\phi 3.0 \sim \phi 12.0$

CODE No.

ST20 SSF10 S 150
 Shank Chucking Dia Shim Length

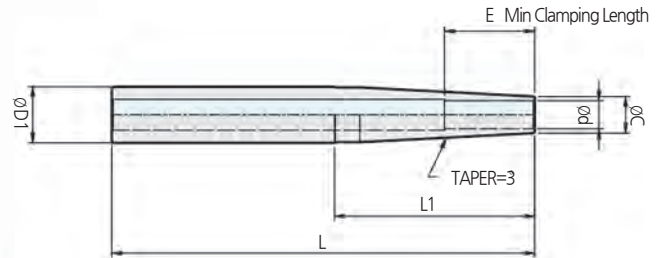

PRODUCT INFORMATION

- 4D선단에서 3 μ m이내의 흔들림 정도
- 높은 정밀도와 강력한 파지력
- 대칭적, 슬림한 디자인으로 가공최적화
- 전제품 내부급유 Coolant Through Hole
- 3 μ m(T.I.R) Run-out at 4D away from shank nose.
- Excellent Run-out accuracy and powerful clamping.
- Optimal operation with slim and symmetrical design.
- All products can be used for center through coolant type.

Code No.	ϕd	ϕC	$\phi D1$	L	L1	E	Weight (kg)
ST12 - SSF 4S - 120	4	7	12	120	47.7	12	0.1
SSF 6S - 120	6	7			28.6	18	0.1
ST16 - SSF 3S - 120	3	6	16	120	51	16	0.1
SSF 4S - 120	4	7					0.1
SSF 6S - 120	6	9					0.15
ST20 - SSF 3S - 150	3	6	20	150	40	16	0.25
SSF 4S - 150	4	7					0.25
SSF 6S - 150	6	9		200	110	26	0.25
- 200							0.3
- 250							0.4
SSF 8S - 150	8	11		200	90	26	0.25
- 200							0.3
- 250							0.4
SSF10S - 150	10	13		200	71	32	0.25
- 200							0.35
- 250							0.4
SSF12S - 150	12	15		200	52	36	0.25
- 200			0.35				
- 250			0.45				

- ▶ 열박음홀더 사용시 절삭공구 Shank경은 h6의 제품을 사용해 주십시오.
- ▶ 절삭공구는 초경 Shank만 대응합니다. (하이스 제품 사용금지)
- ▶ 열박음홀더 사용시 지정된 고주파 히팅기를 사용해서 절삭공구 체결을 권장합니다.
- ▶ SELUX 고주파 히팅기는 P153
- ▶ 절삭공구 최소 삽입길이를 준수해 주시기 바랍니다.
- ▶ 공구길이조정 Stopper는 별도 판매 입니다. P153
- ▶ 열박음척 사용시 척 내경에 있는 방청유를 제거후에 사용하셔야 합니다. 내구성 저하 원인이 됩니다.
- ▶ Please use only carbide cutting tools of a shank tolerance within H6 .
- ▶ Please use only carbide cutting tools for shink fit holder. (Prohibit use HSS CUTTING TOOLS)
- ▶ We recommend shrink fit equipment when you use shink fit holder.
- ▶ SELUX shrink fit equipment is refered. P153
- ▶ Please follow minimum insertion lengh of the cutting tools.
- ▶ Stopper for adjusting cutting tool lengh order separately. P153
- ▶ Please clean the shank outside and inside of shrink fit before use. If you don't clean the shrink fit, it has problem about Run-out and tollifge.

ST SHANK SHRINK FIT HOLDER

SHRINK FIT HOLDER

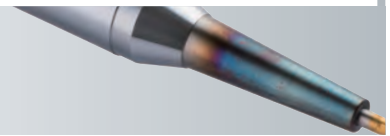

Coolant-through hole
Clamping Range : $\phi 3.0 \sim \phi 20.0$

CODE No.

ST32 SSF10 150
Shank Chucking Dia Length

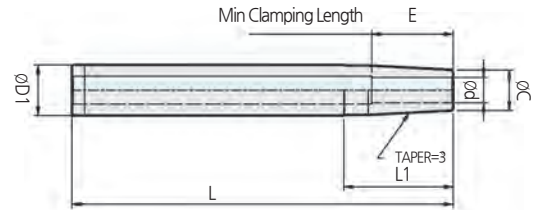

PRODUCT INFORMATION

- 4D선단에서 3 μ m이내의 흔들림 정도
- 높은 정밀도와 강력한 파지력
- 대칭적, 슬림한 디자인으로 가공최적화
- 전제품 내부급유 Coolant Through Hole
- 3 μ m(T.I.R) Run-out at 4D away from shank nose.
- Excellent Run-out accuracy and powerful clamping.
- Optimal operation with slim and symmetrical design.
- All products can be used for center through coolant type.

Code No.	ϕd	ϕC	$\phi D1$	L	L1	E	Weight (kg)
ST20 - SSF 4 - 150	4	8	20	150	40	16	0.3
SSF 6 - 150					62		0.3
- 200					100		0.35
- 250							0.4
SSF 8 - 150	8	13		150	71	26	0.3
- 200				200			0.35
- 250				250			0.4
SSF10 - 150				10			16
- 200	200	0.5					
- 250	250	0.6					
ST32 - SSF10 - 150	10	16	150		70	32	
- 200			200	0.8			
- 300			250	1.2			
SSF12 - 150			12	19			150
- 200	200	0.8					
- 300	300	1.25					
SSF16 - 150	16	24			150	83	38
- 200			200	0.9			
- 300			300	1.3			
SSF20 - 150			20	28	150		
- 200	200	0.9					
- 300	300	1.3					

- ▶ 열박음홀더 사용시 절삭공구 Shank경은 h6의 제품을 사용해 주십시오.
- ▶ 절삭공구는 초경 Shank만 대응합니다. (하이스 제품 사용금지)

- ▶ 열박음홀더 사용시 지정된 고주파 히팅기를 사용해서 절삭공구 체결을 권장합니다.
- ▶ SELUX 고주파 히팅기는 P153
- ▶ 절삭공구 최소 삽입길이를 준수해 주시기 바랍니다.
- ▶ 공구길이조정 Stopper는 별도 판매 입니다. P153
- ▶ 열박음척 사용시 척 내경에 있는 방청유를 제거후에 사용하셔야 합니다. 내구성 저하 원인이 됩니다.

- ▶ Please use only carbide cutting tools of a shank tolerance within H6.
- ▶ Please use only carbide cutting tools for shrink fit holder. (Prohibit use HSS CUTTING TOOLS)
- ▶ We recommend shrink fit equipment when you use shrink fit holder.
- ▶ SELUX shrink fit equipment is referred. P153
- ▶ Please follow minimum insertion length of the cutting tools.
- ▶ Stopper for adjusting cutting tool length order separately. P153
- ▶ Please clean the shank outside and inside of shrink fit before use. If you don't clean the shrink fit, it has problem about Run-out and tool life.

STRAIGHT ER COLLET CHUCK (MILLING)



Coolant-through hole
Clamping Range : $\phi 0.5 \sim \phi 20.0$

CODE No.

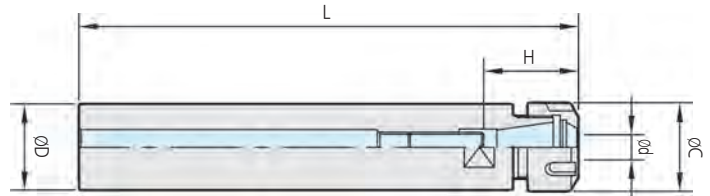
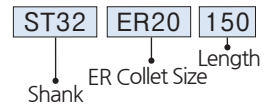

PRODUCT INFORMATION

- 안정적인 정밀도와 파지력
- 쉽고빠른 공구교환
- 드릴, 엔트밀, 탭 다양한 사용범위
- Reliable accuracy and Powerful clamping force.
- Easy and quick tool exchange.
- ER COLLET CHUCK is suitable for a various operation using drill, endmill, tap.

Code No.	ϕd	ϕD	L	ϕC	H		Collet	Weight (kg)
					Min	Max		
ST16 - ER11 - 120	0.5~7.0	16	120	19	19	34	ER11	0.2
ER16 - 150	0.5~10.0		150	28	23	43	ER16	0.2
ST20 - ER16 - 150	0.5~10.0	20	150	28	23	43	ER16	0.3
ER20 - 150	1.0~13.0			35	25	48	ER20	0.3
ST25 - ER16 - 150	0.5~10.0	25	150	28	23	43	ER16	0.5
ER20 - 150	1.0~13.0			35	25	48	ER20	0.5
ER25 - 150	1.0~16.0			42	34	54	ER25	0.6
ST32 - ER20 - 150	1.0~13.0	32	150	35	25	48	ER20	0.7
ER25 - 150	1.0~16.0			42	34	54	ER25	0.7
ER32 - 165	2.0~20.0		165	50	40	60	ER32	0.8
- 300		300					1.2	

- ▶ 내부급유 사용시에는 방수형콜릿이나 방수형 너트를 사용 해주십시오.
- ▶ ER콜릿은 P146
- ▶ 스페너는 별매했습니다. P157
- ▶ Please use waterproof collet and waterproof nut for operating centre through coolant type.
- ▶ ER COLLET is referred. P146
- ▶ Spanner is ordered separately. P157

ST SHANK

STRAIGHT ER COLLET CHUCK (MILLING)

STRAIGHT ER COLLET CHUCK (CNC)

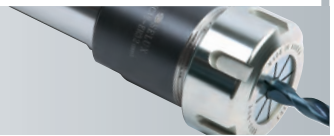

Coolant-through hole
Clamping Range : $\phi 0.5 \sim \phi 20.0$

CODE No.
NC32 ER20
 ↓ ↓
 Shank ER Collet Size

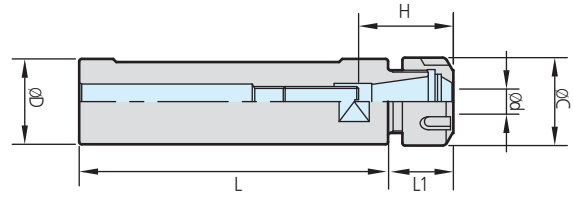

PRODUCT INFORMATION

- NC 선반, 소형 CNC 선반의 기본 Holder로서 (드릴, 센터드릴, 엔드밀, 탭, 소경 보링바, 리머) 등을 사용. 특히 내경 보링바 (바이트)의 슬리브용으로 절삭 진동을 흡수하는 효과를 발휘하여 능률을 대폭 향상.
- 안정적인 정밀도와 파지력
- 쉽고 빠른 공구교환
- 드릴, 엔드밀, 탭 다양한 사용범위
- Chuck is using as a tool holder(drill, center drill, endmill, tap, boring bar, reamer) for NC lathe and small CNC lathe, when it is used for sleeve of internal boring bar (bite), in particular, it is excellent increases the pro-ductivity by absorbing cutting vibration.
- Reliable accuracy and Powerful clamping force.
- Easy and quick tool exchange.
- ER COLLET CHUCK is suitable for a various operation using drill, endmill, tap.

Code No.	ϕd	ϕD	L	L1	ϕC	H		Collet	Weight (kg)
						Min	Max		
NC25 - ER11	0.5~7.0	25	68	20	19	19	34	ER11	0.3
ER16	0.5~10.0		68	25	28	23	43	ER16	0.5
ER20	1.0~13.0		86	27	35	25	48	ER20	0.5
ER25	1.0~16.0		68	50	42	34	54	ER25	0.6
NC32 - ER16	0.5~10.0	32	72	25	28	23	43	ER16	0.5
ER20	1.0~13.0		72	27	35	25	48	ER20	0.6
ER25	1.0~16.0		100	28	42	34	54	ER25	0.7
ER32	2.0~20.0		72	57	50	40	60	ER32	0.8
NC40 - ER16	0.5~10.0	40	75	25	28	23	43	ER16	1.0
ER20	1.0~13.0		75	27	35	25	48	ER20	1.1
ER25	1.0~16.0		91	28	42	34	54	ER25	1.2
ER32	2.0~20.0		93	31	50	40	60	ER32	1.3

Spare Parts				
Type	Option			
	NUT	Adjust Screw	Spanner	ER Collet
ER11	UM/ER11(HEXA)	BTD0716-C	ER11-SP	ER11- ϕ
ER16	UM/ER16(HEXA)	BTD1025-C	ER16-SP	ER16- ϕ
ER20	UM/ER20(HEXA)	BTD1325-C	ER20-SP	ER20- ϕ
ER25	UX/ER25	BTD1830-C	ER25-SP	ER25- ϕ
ER32	UX/ER32	BTD2230-C	ER32-SP	ER32- ϕ
ER40	UX/ER40	BTD2838-C	ER40-SP	ER40- ϕ

- ▶ 내부급유 사용시에는 방수형 콜릿이나 방수형 너트를 사용 해주십시오. ▶ Please use waterproof collet and waterproof nut for operating centre through coolant type.
- ▶ ER콜릿은 P146 ▶ ER COLLET is referred. P146
- ▶ 스페너는 별매입니다. P157 ▶ Spanner is ordered separately. P157

ST SHANK STRAIGHT ER COLLET CHUCK (CNC)

STRAIGHT SLIM ER COLLET CHUCK (MILLING)



Coolant-through hole
Clamping Range : $\phi 0.5 \sim \phi 16.0$

CODE No.

ST25	ER16	M	105
Shank	ER Collet Size	Slim	Length

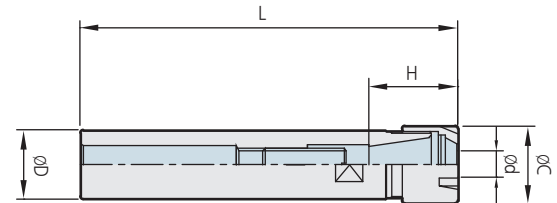

PRODUCT INFORMATION

- 좁고 깊은 곳에 적합
- 뛰어난 정밀도와 파지력
- 척킹 범위 $\phi 0.5\text{mm} \sim \phi 16.0\text{mm}$
- Narrow and depth operation.
- High accuracy and powerful clamping force.
- Chucking Dia $\phi 0.5\text{mm} \sim \phi 16.0\text{mm}$.

Code No.	ϕd	ϕD	L	ϕC	H		Collet	Weight (kg)
					Min	Max		
ST16 - ER11M - 170	0.5~7.0	16	170	16	19	34	ER11	0.2
ST20 - ER16M - 180			180		23	43	ER16	0.3
- 250	0.5~10.0	20	250	22	23	43	ER16	0.4
ER20M - 180			180					25
- 250	1.0~13.0	25	250	28	25	48	ER20	
ST25 - ER16M - 180			0.5~10.0					25
- 250	250	23		43	ER16	0.6		
ER20M - 185	1.0~13.0		25			185	28	25
- 250		250		25	48	ER20		
ST32 - ER20M - 200	1.0~13.0	32	200				28	25
- 300			300	25	48	ER20		
ER25M - 200	1.0~16.0	32	200				35	34
- 300			300	34	54	ER25		

Type	Spare Parts			
	Basic		Option	
	NUT	Adjust Screw	Spanner	Collet
ER11M	SM/ER11M	BTD0716-C	ER11M-SP	ER11- ϕ
ER16M	SM/ER16M	BTD1025-C	ER16M-SP	ER16- ϕ
ER20M	SM/ER20M	BTD1325-C	ER20M-SP	ER20- ϕ
ER25M	SM/ER25M	BTD1830-C	ER25M-SP	ER25- ϕ

- ▶ ER콜릿은 P146
- ▶ 스페너는 별매입니다.
- ▶ ER COLLET is referred. P146
- ▶ Spanner is ordered separately.

ST SHANK

STRAIGHT SLIM ER COLLET CHUCK (MILLING)

GYRO CHUCK



Clamping Range : $\varnothing 0.5 \sim \varnothing 16.0$

CODE No.

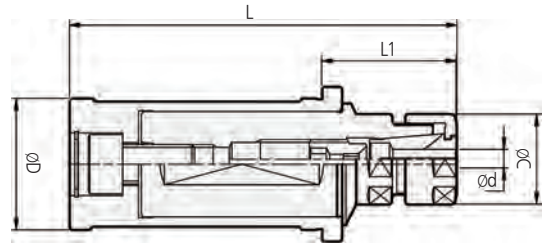
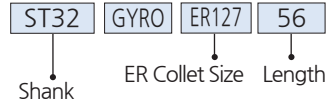

PRODUCT INFORMATION

- CNC선반에서 드릴, 탭, 리머 작업시 장비의 공구편심으로 발생하는 문제를 단시간에 해결.
- GYRO척은 기존 X, Z축 터렛움직임에 Y축 미세조정을 할 수 있습니다.
- CNC선반 홀 가공에서 혁신적인 생산성 향상과 공구비용 절감효과
- 정밀한 가공으로 추가 보링작업 생략가능.
- GYRO CHUCK solve simply the chronic problems of the CnC Lathe about eccentric cutting tool when drilling, tapping, reamer.
- GYRO CHUCK allow sensitivity adjustment of Y (inculde X,Z).
- It Improves tool life and is effective the production of growth when operating hole.
- Pricision operation. (Don't need boring after drilling)

Code No.	$\varnothing d$	$\varnothing D$	L	L1	$\varnothing C$	Max Length.	Weight (kg)
ST32E - GYRO ER16 - 56	0.5~10.0	32	127	56	28	50	2.2
GYRO SSK10 - 56	1.75~10.0				27.5	60	2.2
ST40E - GYRO ER16 - 67	0.5~10.0	40	140	67	28	50	2.8
GYRO ER25 - 67	1.0~16.0				42	60	3.0
GYRO SSK10 - 67	1.75~10.0				27.5	60	2.8

사용방법 instructions

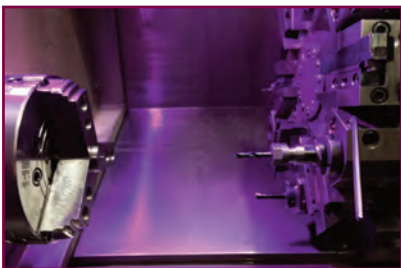

1. 터렛에 있는 홀더고정 볼트와 GYRO척 뒤쪽에 있는 볼트를 풀어준다.
Please release bolt in turret and bolt in GYRO chuck

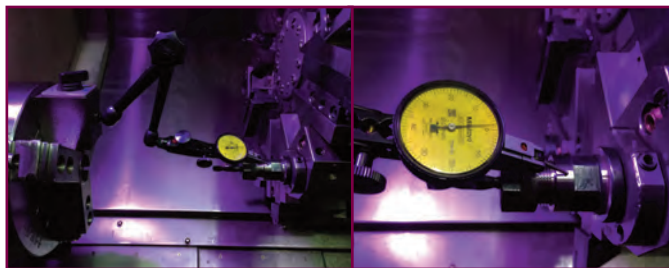

2. 선반척에 인디게이터 부착후 돌려가며 GYRO척의 상크부의 동심도를 체크한다.
check RUN-OUT at shank of GYRO by turning the chuck of cnc lathe after fix the indicator on the chuck of cnc lathe for check how much the lathe have eccentric value



3. 동심도 체크후 틀어진 양만큼 터렛의 X축과 GYRO척의 헤드로 돌려가며 원하는 보정값을 맞춘다.
adjusting head of GYRO chuck and X of cnc lathe by turning the chuck of cnc lathe



4. 풀었던 GYRO척 뒤쪽 볼트를 잠고 터렛의 홀더 고정볼트 위,아래를 한번에 천천히 잠가준다.
Please fasten bolt in turret and bolt in GYRO chuck



5. 완료후 다시한번 보정값을 체크한 후에 가공을 시작한다.
Please finally check the RUN-OUT and start the operation

STRAIGHT NC DRILL CHUCK

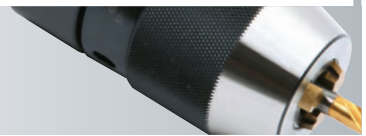

Clamping Range : $\phi 0.5 \sim \phi 13.0$

CODE No.

ST32 NPU13

Shank Chucking Dia

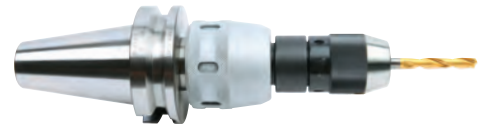
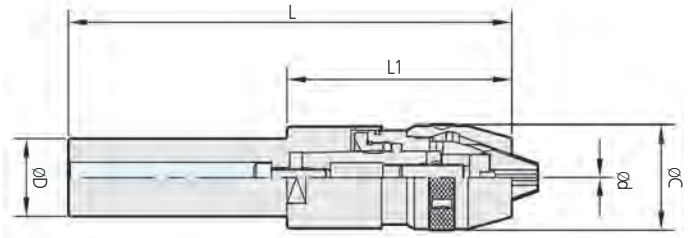

PRODUCT INFORMATION

머시닝 센터의 일반적인 드릴링 공구입니다.

- 척과 샤프트가 일체형 구조로 길이가 짧음
- 가공정도 향상과 우수한 내구성
- 척의 탈락이 없고 주축 정지시 풀리지 않음

General Drillings for Machining Centers

- Unified body of chuck and shank reduces the length of tool.
- Improved working accuracy and superior durability.
- Chuck never detached at the sudden stop of main shaft.

Code No.	ϕd	ϕD	L	L1	ϕC	Weight (kg)
ST32 - NPU 8	0.3~0.8	32	150	80	38	1.0
NPU 13	1.0~13.0		175	105	50	1.5
ST42 - NPU 8	0.3~0.8	42	155	80	38	2.3
NPU 13	1.0~13.0		180	105	50	2.8

Spare Parts

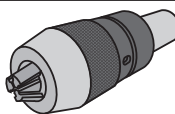
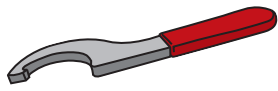
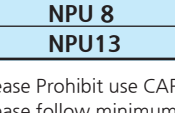
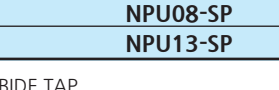
Type	Basic	
	Chuck	Spanner
NPU 8		
NPU13		
	NPU 8	NPU08-SP
	NPU13	NPU13-SP

- ▶ 초경 드릴, 탭은 절대 사용을 금지해 주십시오.
- ▶ 절삭공구 최소 척강 길이를 준수해 주시기 바랍니다.
NPU8-20mm이상
NPU13-30mm이상
- ▶ 스페너는 별매했습니다.

- ▶ Please Prohibit use CARBIDE DRILL and CARBIDE TAP.
- ▶ Please follow minimum length of cutting tools.
NPU8 : more 20mm
NPU13 : more 30mm
- ▶ Spanner is ordered separately.

STRAIGHT TAPPING CHUCK



Tapping Range : M3 ~ M24

CODE No.

ST32	TCH22	165
Shank	MAX Tapping	Length

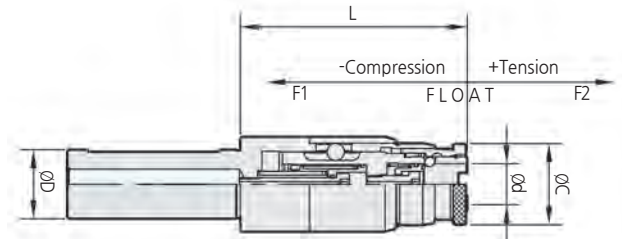

PRODUCT INFORMATION

- 플로팅 타입으로 인장수축 장치 내장
- 공구교환이 빠르고 편리함
- 관통구멍과 막힌구멍의 tapping 및 모든 tap 작업 가능
- The tapping chuck is equipped with tension system by floating type.
- Easy and quick tool exchange.
- It is possible for tapping operation of blind hole and through hole.

Code No.	ød	L	øC	øD	L1		Weight (kg)
					F1	F2	
ST32- TCH12- 125	19	100	35	32	6	12	1.4
TCH22- 165	31	130	52		10	15	1.8
ST40- TCH12- 120	19	95	35	40	6	12	2.2
TCH22 - 160	31	125	52		10	15	2.4
ST42- TCH12- 120	19	95	35	42	6	12	2.8
TCH22 - 160	31	125	52		10	15	3.0

▶ 적용 탭콜릿은 P149

▶ Private tap collets are referred. P149

FLOATING ER TAP CHUCK



Clamping Range : ø0.5 ~ ø20.0

※ CNC 선반 TAP작업시 능률 UP!!

CODE No.

ST40	FTER32	85
Shank	ER Collet Size	Length

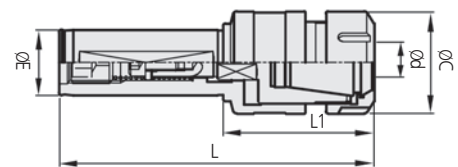

PRODUCT INFORMATION

- 플로팅 타입으로 탭 파손 방지
- Prevent the tap from breaking by frotting type.

Code No.	ød	øC	L	L1	Collet	øE	Weight (kg)
ST32 - FTER16 - 65	0.5~10.0	23	145	65	ER16	32	2.0
ST40 - FTER32 - 75	2.0~20.0	50	165	75	ER32	40	2.8

- ▶ CNC 선반 에서 탭작업가능
- ▶ SLA, MC척에 사용가능 합니다.
- ▶ ER콜릿은 P146
- ▶ 스패너는 별매입니다. P157

- ▶ It can do tapping operation at the CNC lathe.
- ▶ It can use with SIDE LOCK ARBOR and MILLING CHUCK.
- ▶ ER COLLET is referred. P146
- ▶ Spanner is ordered separately. P157

STRAIGHT FACE MILL ARBOR



CODE No.

ST32 FMA25.4

Shank

Cutter Type

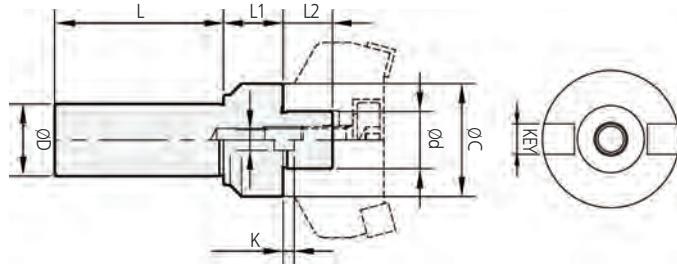

PRODUCT INFORMATION

■ Sandvik T-MAX face mill cutter 전용 arbor 입니다. ■ Only For T-MAX face mill cutter arbor manufactured by sandvik.

Code No.	ød	Cutter Dia	øD	L	L1	L2	øC	Key	K
ST20 - FMA25.4 (3R)	25.4	80	20	68	22	25	50	K9.5 - S	5
ST32 - FMA25.4 (3R)			32						
FMA31.75 (4R)	31.75	100	32	75	25	30	60	K12.7 - S	7
ST42 - FMA25.4 (3R)	25.4	80	42	80	22	25	50	K9.5 - S	5
FMA31.75 (4R)	31.75	100							

Spare Parts

Type	Basic			
	Key	Clamp Bolt	Key Bolt	Wrench Bolt
FMA 25.4				
FMA 31.75	K12.7	MBA-M16	BX0515	-
FMA 38.1	K15.85	MBA-M20	BX0616	-
FMA 50.8	K19	MBA-M24	BX0820	-
FMA 47.625	K25.4	-	BX1020	BX1645

▶ 스페어 파트 주문시에는 반드시 품명의 정확한 확인이 필요합니다.
▶ Key 주문시에는 제품상세표에서 LONG/Short Key를 확인해주세요.

▶ Please pay attention to check spare parts list when you order.
▶ Please check long/short key when you order.

ST SHANK
STRAIGHT FACE MILL ARBOR

STRAIGHT FACE MILL ARBOR



CODE No.

ST32 FMC22

Shank

Cutter Type

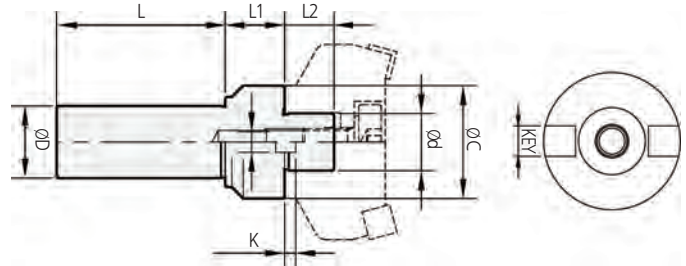

PRODUCT INFORMATION

■ Sandvik T-MAX face mill cutter 전용 arbor 입니다. ■ Only For T-MAX face mill cutter arbor manufactured by sandvik.

Code No.	ød	Cutter Dia	øD	L	L1	L2	øC	Key	K
ST20 - FMC16	16	40	20	68	18	17	38	K8-S	5
FMC22	22	50/63			20	18	45	K10-S	5.5
ST32 - FMC16	16	40	32	75	18	17	38	K8-S	5
FMC22	22	50/63			20	18	45	K10-S	5.5
FMC27	27	63/80			22	20	60	K12-S	6
ST42 - FMC22	22	50/63	42	80	20	18	45	K10-S	5.5
FMC27	27	63/80			22	20	60	K12-S	6

SpareParts

Type	Basic			
	Key	Clamp Bolt	Key Bolt	Wrench Bolt
FMC16	K8	-	BX0310	BX0820
FMC22	K10	-	BX0412	BX1025
FMC25.4	K9.5	MBA-M12	BX0412	BX1230(Option)
FMC27	K12.0	MBA-M12	BX0515	BX1230(Option)
FMC32	K14.0	MBA-M16	BX0615	BX1635(Option)
FMC38.1	K15.85	MBA-M16	BX0615	BX1635(Option)
FMC40	K15.85	MBA-M20	BX0615	BX1230(Option)

▶ 스페어 파트 주문시에는 반드시 품명의 정확한 확인이 필요합니다.
▶ Key 주문시에는 제품상세표에서 LONG/Short Key를 확인해주시시오.

▶ Please pay attention to check spare parts list when you order.
▶ Please check long/short key when you order.

ST PRO MILL ARBOR (CARBIDE)



CODE No.

ST16	M06	150
Shank	Cutter Type	Length

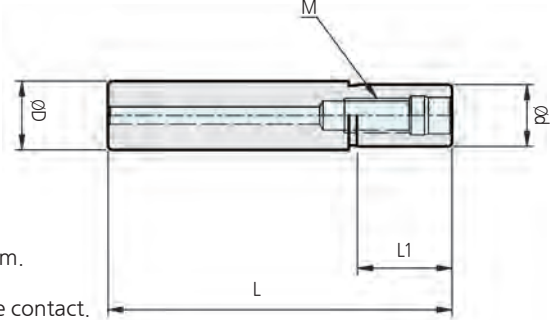

PRODUCT INFORMATION

- 모듈라 방식으로 원가 절감
- 높은 정밀도
- 이면구속 체결로 흔들림 감소
- 헤드 교체로 다양한 작업가능
- Cost reduction effect with modular system.
- Excellent accuracy.
- Vibration damping effect due to dual face contact.
- A various operation with exchanging head.

Code No.	øD	ød	L	L1	M
ST10 - M06 - 150	10	9.8	150	24	M6
ST12 - M06 - 150	12	10.8	150	30	M6
ST16 - M06 - 150	16	14.4	120	24	M8
			200		
ST20 - M10 - 200	20	18	200	40	M10
			250		
ST25 - M12 - 250	25	22.5	250	48	M12
			300		

ST SHANK

ST PRO MILL ARBOR (CARBIDE) / ST PRO MILL CUTTER(Ball Type)

ST PRO MILL CUTTER(Ball Type)

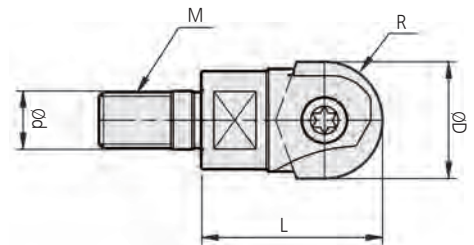

PRODUCT INFORMATION

- HITACHI 인서트 호환
- 정삭 R작업 최적화
- Compatible with HITACHI insert.
- Optimal for R-finishing operation.

Code No.	R	øD	L	ød	M	Insert	Screw	Wrench
R05M0630	5	10	30	6.5	M6	ZPFG100, ZCFW100	TNS-5842	TXL-10
R06M0630	6	12				ZPFG120, ZCFW120	TNS-5843	TXT-20
R08M0830	8	16		8.5	M8	ZPFG160, ZCFW160	TNS-5844	
R10M1035	10	20	35	10.5	M10	ZPFG200, ZCFW200	TNS-5845	TXT-25
R12M1240	12.5	25	40	12.5	M12	ZPFG250, ZCFW250	TNS-5846	TXT-30

▶ 다양한 Type의 커터 제작가능합니다.
▶ 전용 스패너는 별매.

▶ Cutters can be made of a variety of Type.
▶ Spanner is orderd seperately.

Excellent Precision
Excellent Quality

SELUX
NC TOOLING SYSTEM

ACCESSORY

CHUCK & Item

HYDRAULIC COLLET
K-COLLET (K TYPE)
K-COLLET (NC TYPE)
K-COLLET (COOLANT)
TAPER COLLET
DRILL CHUCK COLLET
SC COLLET
ER COLLET and SET
SE COLLET
TER COLLET
TAP ADAPTER
TEST BAR
CENTERING PLUG
BLANK TOOL
TAPER SLEEVE ADAPTER
SLEEVE ADAPTER
SHRINK FIT MACHINE
TOOL SETTING STAND
UNIVERSAL MAGNETIC BASE
SPINDLE CLEANER
TOUCH POINT SENSOR
HEIGHT PRESETER
ZOP-50
SPANNER
GH SPANNER
PULL STUD BOLT
PULL STUD BOLT SPEC



HYDRAULIC COLLET

Coolant-through hole
Clamping Range : $\phi 3.0 \sim \phi 25.0$

D-Collet

CODE No.

D32	20
Shank	Chucking Dia

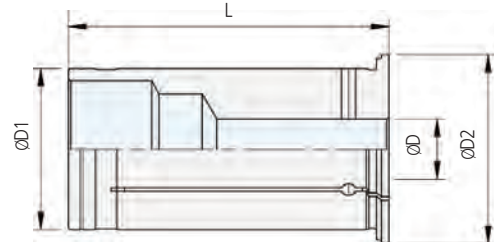

PRODUCT INFORMATION

- 스페셜 SIZE는 주문제작.
- 공구 체결시 COLLET에 공구를 먼저 삽입한후 유압척에 콜릿을 삽입하시길 바랍니다.

- The speical size is made by order.
- Please insert collet in HYDRAURIC CHCUK after inserting the cutting tool in the collet.

Style	D1	D2	L	Weight (g)
D8	8	12.5	37.5	25
D12	12	16.5	47	45
D20	20	24.6	52	90
D32	32	37.5	63.5	280

Style	HYDRAULIC COLLET
D8	2,3,4,5,6
D12	3,4,5,6,8,9,10
D20	3,4,5,6,7,8,9,10,11,12,13,14,15,16,17,18
D32	6,8,10,12,14,16,18,19,20,25

ACCESSORY

HYDRAULIC COLLET

HYDRAULIC COLLET

Coolant-through hole
Clamping Range : $\phi 3.0 \sim \phi 25.0$

OD-Collet

CODE No.

OD32	20
Shank	Chucking Dia

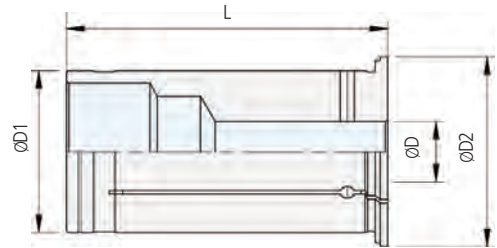

PRODUCT INFORMATION

- 스페셜 SIZE는 주문제작.
- 공구 체결시 COLLET에 공구를 먼저 삽입한후 유압척에 콜릿을 삽입하시길 바랍니다.
- 방수타입콜릿은 정밀도를 보증하기 위해 정밀 커팅으로 작업되어 있습니다.

- The speical size is made by order.
- Please insert collet in HYDRAURIC CHCUK after inserting the cutting tool in the collet.
- Waterproof collet has been cut very precisely to guarantee accuracy.

Style	D1	D2	L	Weight (g)
OD8	8	12.5	37.5	25
OD12	12	16.5	47	40
OD20	20	24.6	52	90
OD32	32	37.5	63.5	280

Style	HYDRAULIC COLLET
OD8	2,3,4,5,6
OD12	3,4,5,6,8,9,10
OD20	3,4,5,6,7,8,9,10,11,12,13,14,15,16,17,18
OD32	6,8,10,12,14,16,18,19,20,25

K-COLLET (K TYPE)



Coolant-through hole
Clamping Range : $\phi 3.0 \sim \phi 32.0$



CODE No.

K32 8

Chucking Dia
Shank

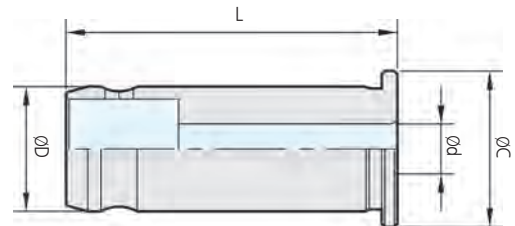

PRODUCT INFORMATION

- 밀링척용 collet
- 스페셜 size는 주문제작
- 인치 size 주문제작(K-32 제외)
- K-COLLET 전Size 재고관리
- ●표는 표준외 품목
- Straight Collet is for Milling Chuck.
- The speical size is made by order.
- The inch size is made by order.
- We keep the stock for all size K-COLLET.
- The mark ● indicates the special size.

Style	ϕD	L	ϕC	Weight (kg)
K 20	20	55	25	0.1
K 25	25	59	30	0.2
K 32	32	65	37	0.3
K 42	42	70	47	0.5

Style	K-COLLET
K20	3, 4, 5, 6, 7, 8, 9, 10, 11, 12, 13, 14, 15, 16, 17, 18
K25	6, 8, 10, 12, 14, 15, 16, 18, 20
K32	3, 4, 5, 6, 7, 8, 9, 10, 11, 12, 13, 14, 15, 16, 17, 18, 19, 20 21, 22, 23, 24, 25, 26, 27, 28
	3.5, 4.5, 5.5, 6.5, 7.5, 8.5, 9.5, 10.5, 11.5, 12.5, 13.5, 14.5, 15.5, 16.5 17.5, 18.5, 19.5, 20.5, 21.5, 22.5, 23.5, 24.5, 25.5, 26.5, 27.5 1/4, 5/16, 3/8, 1/2, 3/4, 5/8, 1
K42	3, 4, 5, 6, 7, 8, 9, 10, 11, 12, 13, 14, 15, 16, 17, 18, 19, 20
	21, 22, 23, 24, 25, 26, 27, 28, 29, 30, 31, 32, 33, 34, 35, 36, 37, 38

Style & ϕd		L	T.I.R()
K20	6,8,10	50	0.02
K25	12,16	75	
K32			
K42	20,25,32	100	

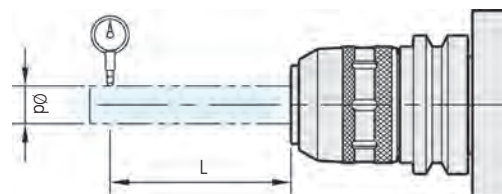

ACCESSORY STRAIGHT COLLET (K TYPE)

K-COLLET (NC TYPE)

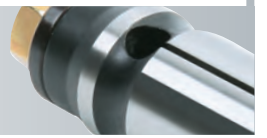

Clamping Range : $\phi 3.0 \sim \phi 32.0$

길이 조절형 타입

CODE No.

NC32 8

Shank Chucking Dia

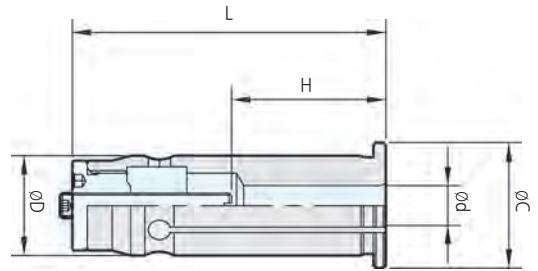

PRODUCT INFORMATION

- 조절나사에 의해 공구길이조정
- 스페셜 size 주문가능

- The length is adjustable with an adjustable screw.
- The speical size is made by order

Code No.	ϕd	ϕD	L	ϕC	H		Weight (kg)
					Min	Max	
NC20 - 6	6	20	63	25	30	50	0.1
- 8	8						
- 10	10						
- 12	12						
- 16	16						
NC25 - 6	6	25	68	30	30	58	0.25
- 8	8						
- 10	10						
- 12	12						
- 16	16						
- 20	20						
NC32 - 6	6	32	75	37	30	62	0.4
- 8	8						
- 10	10						
- 12	12						
- 16	16						
- 20	20						
- 25	25						
NC42 - 6	6	42	87	47	30	72	0.6
- 8	8						
- 10	10						
- 12	12						
- 16	16						
- 20	20						
- 25	25						
- 32	32	92					

K-COLLET (COOLANT TYPE) 방수형

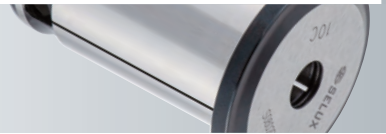

Coolant-through hole
Clamping Range : $\phi 3.0 \sim \phi 32.0$

CODE No.

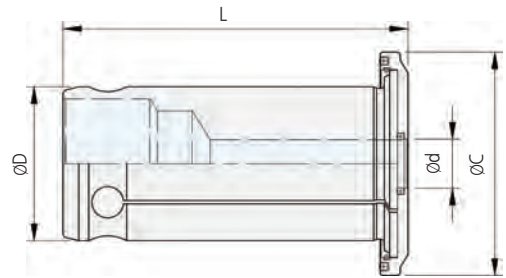
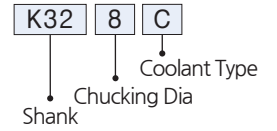

PRODUCT INFORMATION

- 밀링척용 방수 collet
- 스페셜 size는 주문제작
- 인치 size 주문제작
- "●" 표는 표준외 품목

- Water-proof Collet is for Milling Chuck.
- The speical size is made by order.
- The inch size is made by order.
- The mark "●" indicates the special size.

ACCESSORY

STRAIGHT COLLET (C TYPE)

Style	ϕD	L	ϕC	Weight (kg)
K20-C	20	54	34.4	0.1
K25-C	25	64.5	39.4	0.2
K32-C	32	65.5	46.4	0.3

Style	KC-COLLET
K20-C	3, 4, 5, 6, 7, 8, 9, 10, 11, 12, 13, 14, 15, 16, 17, 18
K25-C	3, 4, 5, 6, 7, 8, 9, 10, 11, 12, 13, 14, 15, 16, 17, 18, 19, 20
K32-C	3, 4, 5, 6, 7, 8, 9, 10, 11, 12, 13, 14, 15, 16, 17, 18, 19, 20, 21, 22, 23, 24, 25

Style & ϕd		L	T.I.R()
K20	6,8,10	50	0.02
K25	12,16	75	
K32		100	
K42	20,25,32	100	

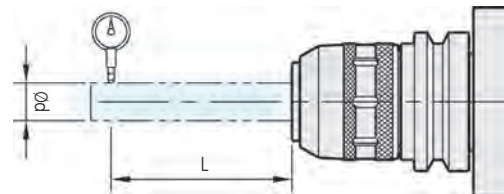

TAPER COLLET

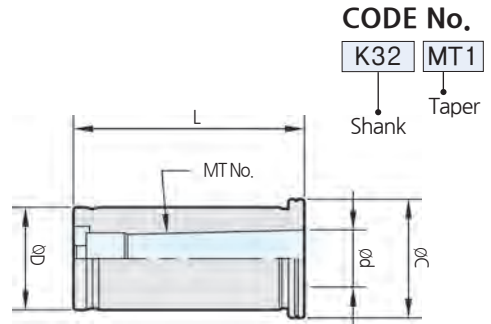

PRODUCT INFORMATION

■ MT샙크 공구 체결용 collet

■ Should be used in MT Shank Tool.

Code No.	ød	MT No.	øD	L	øC	Weight (kg)
K20 - MT1	12.065	MT1	20	60	25	0.2
- MT2	17.780	MT2		72		
K25 - MT1	12.065	MT1	25	60	30	0.3
- MT2	17.780	MT2		72		
K32 - MT1	12.065	MT1	32	60	37	0.5
- MT2	17.780	MT2		72		
- MT3	23.825	MT3		90		
K42 - MT1	12.065	MT1	42	60	47	0.7
- MT2	17.780	MT2		72		
- MT3	23.825	MT3		90		
- MT4	31.267	MT4		113		

DRILL CHUCK COLLET

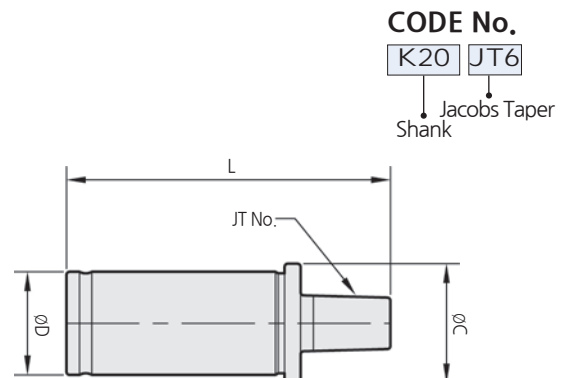

PRODUCT INFORMATION

■ JT샙크 공구 체결용 collet

■ Should be used in JT Shank Tool.

Code No.	JT No.	øD	L	øC	Weight (kg)
K20 - JT6	JT6	20	93	25	0.2
K25 - JT6		25	93	30	0.3
K32 - JT6		32	101	37	0.5
K42 - JT6		42	101	47	0.8

SC COLLET



Coolant-through hole
Clamping Range : $\phi 0.9 \sim \phi 25.4$

CODE No.

SC6 6

↓ Chucking Dia
↓ SC Collet Size



P Class Collet은 전체 Series에 대응이 가능합니다.

PRODUCT INFORMATION

- 8, Taper 의 강력한 파지력
- 일반 타입 콜릿은 5 μ m 정도를 보증
- P Class 콜릿은 3 μ m 정도를 보증
- 전 제품 전수 검사, 품질 보증
- A타입은 End mill 경 size 사용
- C타입은 방수형 전용, 경 SIZE 사용
- Powerful clamping force of 8, taper.
- The standard type is 5 μ m(T.I.R) RUN-OUT accuracy.
- The P CLASS is 3 μ m(T.I.R) RUN-OUT accuracy.
- The quality guaranteed by inspection all products.
- A type is just for endmill of natural number.
- C type is just for waterproof, natural number.

Code No.	Range
SC6 - 2.0	1.75~ 2.0
2.25	2.0 ~ 2.25
2.5	2.25~ 2.5
2.75	2.5 ~ 2.75
3.0	2.8 ~ 3.0
3.175	3.175
3.5	3.0 ~ 3.5
4.0	3.5 ~ 4.0
4.5	4.0 ~ 4.5
5.0	4.5 ~ 5.0
5.5	5.0 ~ 5.5
6.0	5.5 ~ 6.0
SC10 - 2.0	1.75 ~ 2.0
2.25	2.0 ~ 2.25
2.5	2.25 ~ 2.5
2.75	2.5 ~ 2.75
3.0	2.75 ~ 3.0
3.175	3.175
3.5	3.0 ~ 3.5
4.0	3.5 ~ 4.0
4.5	4.0 ~ 4.5
5.0	4.5 ~ 5.0
5.5	5.0 ~ 5.5
6.0	5.5 ~ 6.0
6.5	6.0 ~ 6.5
7.0	6.5 ~ 7.0
7.5	7.0 ~ 7.5
8.0	7.5 ~ 8.0
8.5	8.0 ~ 8.5
9.0	8.5 ~ 9.0
9.5	9.0 ~ 9.5
10.0	9.5 ~ 10.0

Code No.	Range
SC13 - 3.0	2.75 ~ 3.0
3.175	3.175
3.5	3.0 ~ 3.5
4.0	3.5 ~ 4.0
4.5	4.0 ~ 4.5
5.0	4.5 ~ 5.0
5.5	5.0 ~ 5.5
6.0	5.5 ~ 6.0
6.5	6.0 ~ 6.5
7.0	6.5 ~ 7.0
7.5	7.0 ~ 7.5
8.0	7.5 ~ 8.0
8.5	8.0 ~ 8.5
9.0	8.5 ~ 9.0
9.5	9.0 ~ 9.5
10.0	9.5 ~ 10.0
10.5	10.0 ~ 10.5
11.0	10.5 ~ 11.0
11.5	11.0 ~ 11.5
12.0	11.5 ~ 12.0
12.5	12.0 ~ 12.5
13.0	12.5 ~ 13.0

Code No.	Range
SC16 - 3.0	2.75~ 3.0
3.5	3.0 ~ 3.5
4.0	3.5 ~ 4.0
4.5	4.0 ~ 4.5
5.0	4.5 ~ 5.0
5.5	5.0 ~ 5.5
6.0	5.5 ~ 6.0
6.5	6.0 ~ 6.5
7.0	6.5 ~ 7.0
7.5	7.0 ~ 7.5
8.0	7.5 ~ 8.0
8.5	8.0 ~ 8.5
9.0	8.5 ~ 9.0
9.5	9.0 ~ 9.5
10.0	9.5 ~ 10.0
10.5	10.0 ~ 10.5
11.0	10.5 ~ 11.0
11.5	11.0 ~ 11.5
12.0	11.5 ~ 12.0
12.5	12.0 ~ 12.5
13.0	12.5 ~ 13.0
13.5	13.0 ~ 13.5
14.0	13.5 ~ 14.0
14.5	14.0 ~ 14.5
15.0	14.5 ~ 15.0
15.5	15.0 ~ 15.5
16.0	15.5 ~ 16.0

ACCESSORY SC COLLET

SC COLLET



Coolant-through hole
Clamping Range : $\phi 0.9 \sim \phi 25.4$

CODE No.

SC6 6

↓ Chucking Dia
SC Collet Size



Style	ϕD	L	ϕC	L1	H
SC 6	10	25	7.5	17.6	3.8
SC10	15	30.5	12	21.3	5
SC13	19.5	39	15.5	32	5.5
SC16	24	45	18.8	32	8
SC20	28.5	54	23.4	41	8
SC25	35	57	28.9	43	8.5

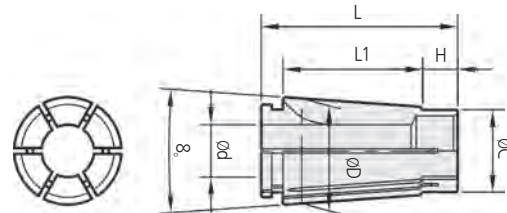

Code No.	Range
SC20 - 4.0	3.6 ~ 4.0
4.5	4.0 ~ 4.5
5.0	4.5 ~ 5.0
5.5	5.0 ~ 5.5
6.0	5.5 ~ 6.0
6.5	6.0 ~ 6.5
7.0	6.5 ~ 7.0
7.5	7.0 ~ 7.5
8.0	7.5 ~ 8.0
8.5	8.0 ~ 8.5
9.0	8.5 ~ 9.0
9.5	9.0 ~ 9.5
10.0	9.5 ~ 10.0
10.5	10.0 ~ 10.5
11.0	10.5 ~ 11.0
11.5	11.0 ~ 11.5
12.0	11.5 ~ 12.0

Code No.	Range
SC20 - 12.5	12.0 ~ 12.5
13.0	12.5 ~ 13.0
13.5	13.0 ~ 13.5
14.0	13.5 ~ 14.0
14.5	14.0 ~ 14.5
15.0	14.5 ~ 15.0
15.5	15.0 ~ 15.5
16.0	15.5 ~ 16.0
16.5	16.0 ~ 16.5
17.0	16.5 ~ 17.0
17.5	17.0 ~ 17.5
18.0	17.5 ~ 18.0
18.5	18.0 ~ 18.5
19.0	18.5 ~ 19.0
19.5	19.0 ~ 19.5
20.0	19.5 ~ 20.0

Code No.	Range
SC25 - 16.0	15.6 ~ 16.0
16.5	16.0 ~ 16.5
17.0	16.5 ~ 17.0
17.5	17.0 ~ 17.5
18.0	17.5 ~ 18.0
18.5	18.0 ~ 18.5
19.0	18.5 ~ 19.0
19.5	19.0 ~ 19.5
20.0	19.5 ~ 20.0
20.5	20.0 ~ 20.5
21.0	20.5 ~ 21.0
21.5	21.0 ~ 21.5
22.0	21.5 ~ 22.0
22.5	22.0 ~ 22.5
23.0	22.5 ~ 23.0
23.5	23.0 ~ 23.5
24.0	23.5 ~ 24.0
24.5	24.0 ~ 24.5
25.0	24.5 ~ 25.0
25.4	25.0 ~ 25.4

- ▶ SC 콜릿 정밀급 주문시 SC10- ϕ P로 주문하여 주십시오.
- ▶ SC 콜릿 방수형 주문시 SC10- ϕ C로 주문하여 주십시오.
- ▶ 너트에서 콜릿 추출시 반드시 콜릿 추출도구를 사용하십시오. SSK척에 부착되어 있습니다.

- ▶ Please order SC10- ϕ P for accuracy SC COLLET. (" P CLASS")
- ▶ Please order SC10- ϕ C for waterproof SC COLLET.
- ▶ Please use collet remover when you separate SK COLLET from NUT. (Collet remover is included)

SE COLLET



Coolant-through hole
Clamping Range : $\phi 6.0 \sim \phi 20.0$

CODE No.

SE20 6

Chucking Dia
SE Collet Size

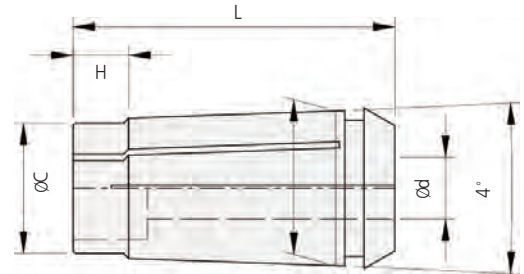

PRODUCT INFORMATION

- 4° Taper 의 강력한 파지력
- 5 μ m 정도를 보증
- 전 제품 전수 검사, 품질 보증
- 정 size End mill 사용

- 4° Taper's powerful wave grip.
- The standard type is 5 μ m(T.I.R) RUN-OUT accuracy.
- The quality guaranteed by inspection all products.
- A type is just for endmill of natural number.

CODE NO.	ϕd	ϕC	H	L	L1	Collet	Weight (kg)
SE20	6,8,10,12	17	7	44.6	30	SE20	60
SE25	6,8,10,12,16	21	9	52.1	35	SE25	110
SE32	6,8,10,12,16,20	28	10	64.1	45	SE32	240

ACCESSORY SE COLLET / ER COLLET

ER COLLET

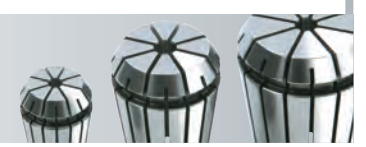

Coolant-through hole
Clamping Range : $\phi 3.0 \sim \phi 32.0$

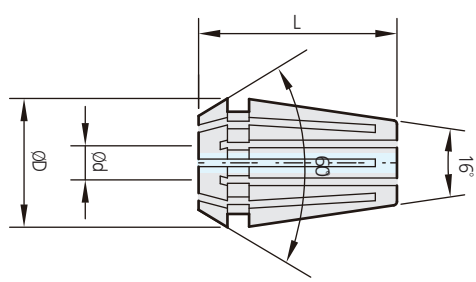

CODE No.

ER11 6

내경
ER Collet Type

PRODUCT INFORMATION

- 높은 정밀도와 다양한 규격
- 강력한 파지력
- $\phi 0.5 \sim \phi 26.0$ mm 척킹

- Excellent accuracy and various specification.
- Powerful gripping.
- Chucking diameter $\phi 0.5 \sim \phi 26.0$ mm

Code No.	Range	ϕD	L	Run-out
ER11- ϕ	0.5	11.5	17.0	0.010
ER16- ϕ	1.0	17.0	27.5	
ER20- ϕ		21.0	31.5	
ER25- ϕ	1.0	26.0	34.0	
ER32- ϕ		33.0	40.0	
ER40- ϕ		41.0	46.0	

- ▶ GER정밀급 콜릿은 당사에 문의 하여 주십시오
- ▶ ER콜릿 방수형 주문시 ER20- ϕ C로 주문 하여 주십시오

- ▶ Please contact us for accuracy collet "GER".
- ▶ Please place your order for the waterproof ER collet as ER20- ϕ C.

ER COLLET SET

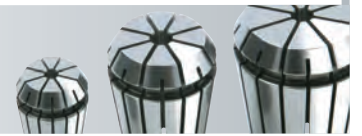

Coolant-through hole
Clamping Range : $\varnothing 3.0 \sim \varnothing 32.0$

CODE No.

ER11 SET

↓ 세트
ER Collet Type

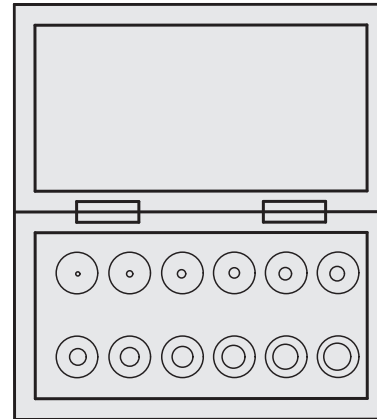

PRODUCT INFORMATION

- 높은 정밀도와 다양한 규격
- Excellent accuracy and various specification.
- 강력한 파지력
- Powerful gripping.
- $\varnothing 0.5 \sim \varnothing 26.0$ mm 척킹
- Chucking diameter $\varnothing 0.5 \sim \varnothing 26.0$ mm

Code No.	Range	Clamping Range	PCS
ER11-Set	0.5	0.5 ~ 7.0	13
ER16-Set	1.0	0.5 ~ 10.0	10
ER20-Set		1.0 ~ 13.0	12
ER25-Set	1.0	1.0 ~ 16.0	15
ER32-Set		2.0 ~ 20.0	18
ER40-Set		3.0 ~ 26.0	23

ACCESSORY ER COLLET SET

TER COLLET



Coolant-through hole
Clamping Range : M2 ~ M24

CODE No.

TER16 6

Chucking Dia
TER Collet Size

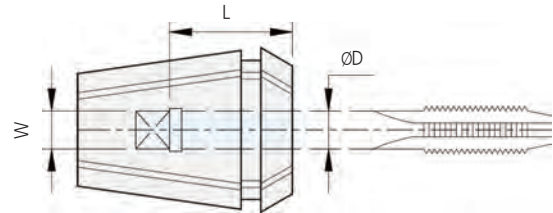

PRODUCT INFORMATION

■ ER 탭콜릿 전용

■ ER Tapcollet only.

Code No.	ØD	L	W
TER16 -M2	3.5	15	2.5
-M3	4	15	3.2
-M4	5	18	4
-M5	5.5	18	4.5
-M6	6	18	4.5
-M8	6.2	18	5
-M10	7	18	5.5

Code No.	ØD	L	W
TER25 - M3	4	15	3.2
- M4	5	18	4
- M5	5.5	18	4.5
- M6	6	18	4.5
- M8	6.2	18	5
- M10	7	18	5.5
- M12	8.5	20	6.5
- M14	10.5	23.5	8

Code No.	ØD	L	W
TER40 - M8	6.2	18	5
- M10	7	18	5.5
- M12	8.5	20	6.5
- M14	10.5	23.5	8
- M16	12.5	23.5	10
- M18	14	25	11
- M20	15	25	12
- M22	17	25	13
- M24	19	28	15

Code No.	ØD	L	W
TER20 - M3	4	15	3.2
- M4	5	18	4
- M5	5.5	18	4.5
- M6	6	18	4.5
- M8	6.2	18	5
- M10	7	18	5.5

Code No.	ØD	L	W
TER32 - M4	5	18	4
- M5	5.5	18	4.5
- M6	6	18	4.5
- M8	6.2	18	5
- M10	7	18	5.5
- M12	8.5	20	6.5
- M14	10.5	23.5	8
- M16	12.5	23.5	10
- M18	14	25	11
- M20	15	25	12
-M22	17	25	13

TEST BAR

기계점검 정도 Check의 필수품
Sub-Zero 처리에 의한 경년변화 방지,
관리에 편리하도록 나무 Box에 보관

CODE No.

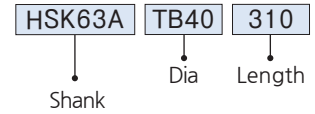

출하시 ϕd 와 L의 실측치수가
마킹되어 있습니다.

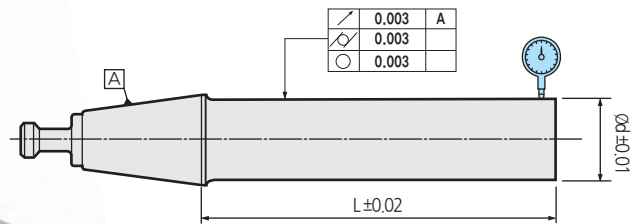

PRODUCT INFORMATION

- ϕd 에 대한 진원도, 직진도, 원통도 0.003mm이내
- 3mm(T.I.R) Runout Accuracy.
- 스페셜 Size 주문제작
- The speical size is made by order.

Code No.	ϕd	L
BT30 - TB28 - 220	28	220
BT40 - TB40 - 310	40	310
BT50 - TB60 - 310	60	310
HSK 40A - TB30 - 170	30	170
HSK 50A - TB40 - 220	40	220
HSK 63A - TB40 - 310	40	310
HSK100A - TB50 - 310	50	310



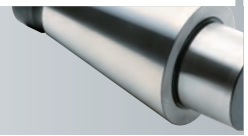

CENTERING PLUG



CODE No.

NT50 CP8(47.625)

Shank Chucking Dia

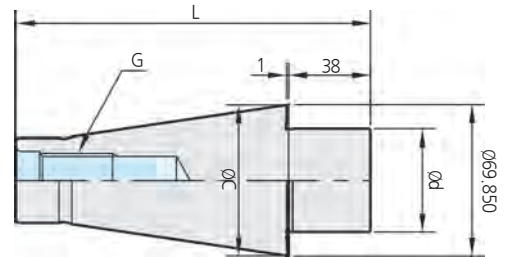

Code No.	ød	Cutter Dia	L	øC	G
NT50 - CP8(47.625)	47.625	200	164	69.56	UNC1"-8
CP8(60)	60				M24X3



BLANK TOOL



CODE No.

HSK63A BLK63 150

Shank Dia Length

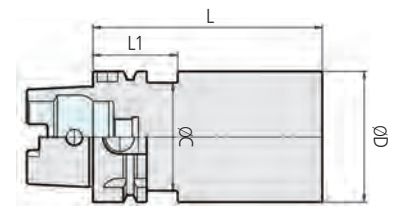

Code No.	øD	øC	L	L1
HSK40A - BLK42 - 180	42	34	180	35
HSK50A - BLK52 - 200	52	42	200	42
HSK63A - BLK63 - 150	63	52	150	42
- 250			250	
BLK82 - 200			200	
HSK100A - BLK 102 - 150	102	85	150	45
- 250			250	
BLK 126 - 200			200	
BT30 - BLK48 - 180	48	44	180	30
BT40 - BLK63 - 150	63	61	150	35
- 250			250	
BLK82 - 200			200	
BT50 - BLK102 - 150	102	98	150	48
- 250			250	
BLK126 - 200			200	

- ▶ 상크부와 테이퍼부의 열처리 경도를 블랭크툴의 특성 및 용도에 맞게 제작되었습니다.
- ▶ 스페셜 Size 주문제작

- ▶ The blank tool has a compatible hardness for use and feature of blank tool.
- ▶ The special size is order-made.

ACCESSORY

CENTERING PLUG / BLANK TOOL

TAPER SLEEVE ADAPTER



CODE No.

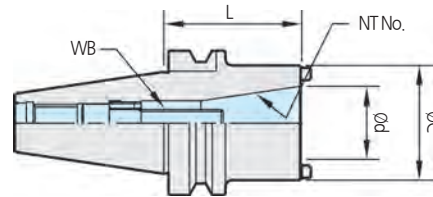
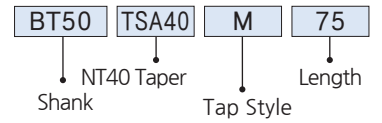

PRODUCT INFORMATION

- NT Type 을 BT Type으로 변환 어댑터
- NT Type Change BT Type Adapter.

Code No.	ød	NT No.	L	øC	WB
BT40 - TSA30U - 60	ø31.75	NT30	60	50	UNC1/2-13
TSA30M - 60					M12 x 1.75
BT50 - TSA40U - 75	ø44.45	NT40	75	70	UNC5/8-11
TSA40M - 75					M16 x 2.0

SLEEVE ADAPTER

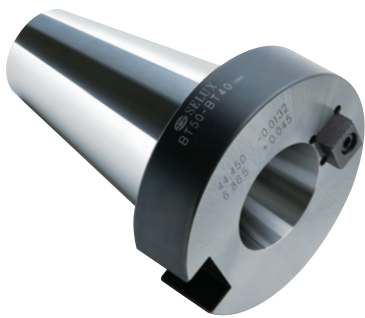

CODE No.

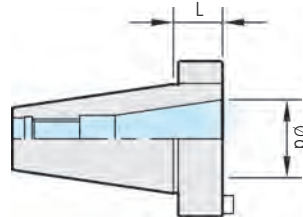
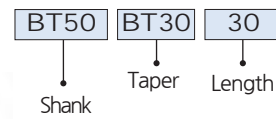

PRODUCT INFORMATION

- 툴 프레스터 전용 공구입니다.
- Tool presetter optional accessories.
- Special size도 제작합니다.
- Special size can be ordered.

Code No.	ød	L
BT40 - BT30 - 20	31.75	20
BT50 - BT30 - 30	31.75	30
BT40 - 30	44.45	30

SHRINK FIT MACHINE



- Equipment dimension 540mm 400mm 780mm (H)
- Box dimension : 660mm 510mm * 860mm

PRODUCT INFORMATION

- HSS 공구 사용 불가
- 간편한 코일 교환과 파워 변경시 자동 인식 시스템 적용
- 정확한 온도 조절 및 셋팅 가능
- 전압 220V
- Quick change coil and automatic identification system
- Precise temperature control
- Bar code system without setting
- Power : AC 220

	MODEL		Range
	MACHINE	POWER	
BASIC	MACHINE	SSF6000	ø3 ~ ø12
	POWER	S0312 POWER	
	SLEEVE	SL-BT50/HSK100	
OPTION	MACHINE	S1232 POWER	ø12 ~ ø32
	COIL	C1216	ø12 ~ ø16
		C1825	ø18 ~ ø25
		C2532	ø25 ~ ø32
	Sleeve	HS-BT30	
		HS-BT40	
		HS-HSK25	
		HS-HSK32	
		HS-HSK40	
		HS-HSK50	
HS-HSK63			
HS-SK40			

Heating Time

ID	CARBIDE	
	IN	OUT
4	5	6
6	6	9
8	5	5
10	6	7
12	8	8
16	8	8
20	8	8
32	15	15

- ▶ 내열장갑은 option
- ▶ S0312 기본포함 사항입니다. 그외 사이즈는 별도 구매입니다.
- ▶ 자세한 사용법 및 주의 사항은 설명서를 참고하여 주시기 바랍니다.
- ▶ 제품고장시 A/S는 당사에 문의하여 주시기 바랍니다.

- ▶ gloves are option
- ▶ S0312 Coil is including basic issue. Other size is a separate purchase.
- ▶ Details of use and precautions refer to instruction.
- ▶ Please contact us for after service.

Stopper



열박음시 공구길이 조정

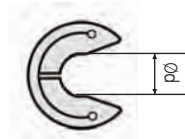

Code No.	ød
STP-ø	3, 3.175, 4, 6, 8, 10, 12, 16, 20, 25

TOOL SETTING STAND



CODE No.

BT50 TSS

Tool setting stand
Shank

PRODUCT INFORMATION

- 45. 형으로 편리한 사용
- HSK용 수직형 타입
- Easy to use by 45. type.
- The vertical type for HSK.

Code No.	Taper	Angle type
BT 30 - TSS	BT30	45.
BT 40 - TSS	BT40	45.
BT 50 - TSS	BT50	45.
HSK 50 - TSS	HSK50	90. (VERTICAL)
HSK 63 - TSS	HSK63	90. (VERTICAL)
HSK100 - TSS	HSK100	90. (VERTICAL)

ACCESSORY

UNIVERSAL MAGNETIC BASE



CODE No.

UMB 340

Length
Universal magnetic base

PRODUCT INFORMATION

- 편리한 조작과 수평길이 340mm의 긴 측정범위
- 강력한 마그네틱 베이스로 완전고정
- 클램프 다이얼 하나로 관절부 완벽고정 흔들림 없음.
- 다이얼 인디게이터는 별도구매

- Easy to use and have a long measuring range that is 340mm.
- Complete fix by powerful magnetic base.
- It is possible to fix axial joint just only fastening the clamp dial.
- The dial indigeiter is not included.

Code No.	Holding Power	BASE SIZE			Arm Length	Weight (kg)
		L	W	H		
UMB-34	80KG	60	50	55	340mm	1.5

TOOL SETTING STAND/UNIVERSAL MAGNETIC BASE

SPINDLE CLEANER

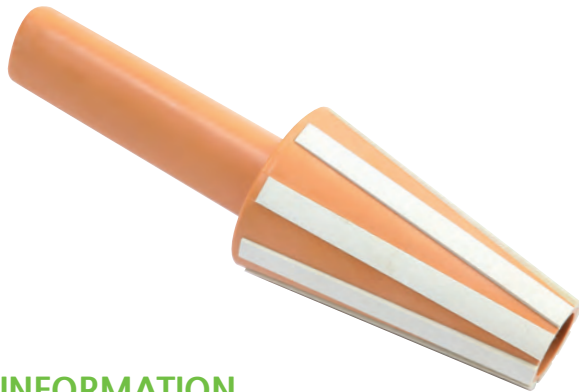

CODE No.

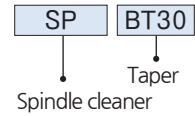

PRODUCT INFORMATION

- 고급 양모지로 제작
- 장비 스피들내의 정전기 발생을 방지하며 스피들과 공구의 수명을 연장가능
- The cleaner is made of lambskin.
- It is for antistatic feature on the machine spindle and improve the tool life and the spindle

Code No.	Taper
SP - BT30	BT30
SP - BT40	BT40
SP - BT50	BT50
SP - HSK50	HSK50
SP - HSK63	HSK63
SP - HSK100	HSK100

TOUCH POINT SENSOR



CODE No.

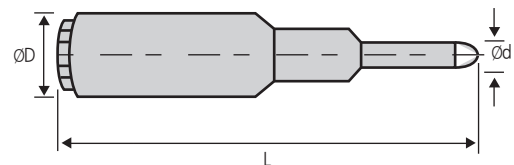
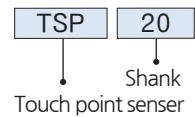

PRODUCT INFORMATION

- 주의: 터치 포인트 센서는 회전시 사용을 금지합니다.
- Notice to optical edge finder that is not suitable used for rotatory.

Code No.	$\varnothing D$	L	$\varnothing d$
TPS - 20	20	158	10
TPS - 32	32	158	10

ACCESSORY

SPINDLE CLEANER / TOUCH POINT SENSOR

HEIGHT PRESETER

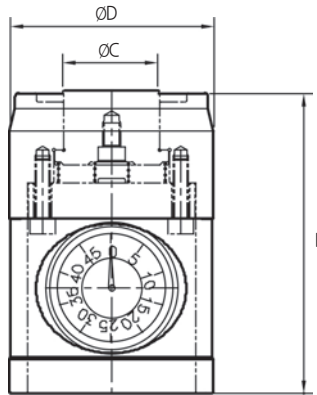

CODE No.
 HP 100
 Height preserter Length

PRODUCT INFORMATION

- MCT/선삭의 커터 길이 설정용
- 설계고도: 100±0.003
- 연마된 평행판을 사용하면 간단히 설정 가능.
- For setting length on machining centers.
- Setting height : 100±0.003
- Easy to be calibrated by a ground parallel or gauge block.

Code No.	Hight	øD	øC	L
HP - 100	100±0.003	68	36	100

ACCESSORY HEIGHT PRESETER / ZOP-50

ZOP-50



CODE No.
 ZOP 50
 Zop Length

PRODUCT INFORMATION

- MCT/선삭의 커터 길이 설정용
- 설계고도 : 50±0.005
- 연마된 평행판을 사용하면 간단히 설정 가능.
- 터치시 발광효과
- For setting length on machining centers.
- Setting height : 50±0.005
- Easy to be calibrated by a ground parallel or gauge block.
- Touch grow effects.

Code No.	Hight
ZOP - 50	50±0.005

SPANNER



CODE No.

MC20 SP

Milling chuck Size Spanner

MC SPANNER		ER, SSK SPANNER			
Code no.	Size	Code no.	ER		SSK
MC20 - SP	50-55	SP	ER11-SP		SC 6-SP
MC25 - SP	56-61		ER16-SP	←-----→	SC10-SP
MC32 - SP	68-73		ER20-SP		SC13-SP
MC42 - SP	88-96		ER25-SP	←-----→	SC16-SP
			ER32-SP	←-----→	SC20-SP
			ER40-SP	←-----→	SC25-SP

GH SPANNER



CODE No.

GH20 SP

Size Spanner

- GH스팬들은 사용이 간편하며 고속회전용 너트에 대응합니다.
- 일반스팬너의 50% 힘만으로 체결이 가능 합니다.

- GH spanner is for high speed nut and easy to use.
- It just need 50% power comparing to general spanner.

GH SPANNER					
Code no.	HIGH SPEED MILLING CHUCK			HIGH SPEED GSK COLLET CHUCK	
GH6 - SP					SC 6-PH
GH10 - SP					SC10-PH
GH16 - SP					SC16-PH
GH20 - SP		MC20-GH	←-----→		SC20-PH
GH25 - SP		MC25-GH	←-----→		SC25-PH
GH32 - SP		MC32-GH			

ACCESSORY
SPANNER / GH SPANNER

PULL STUD BOLT



CODE No.

P40T 1

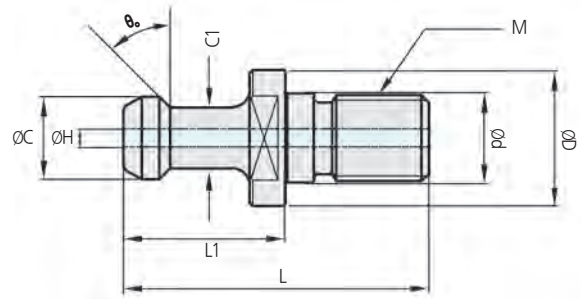

PRODUCT INFORMATION

- 인장강도가 높은 소재사용
- 침탄열처리
- 완전 연마 처리
- Raw material that has excellent tensile strength.
- Cementation heat treatment.
- Complete grinding face.

Code No.		φd	φD	L	φC	C1	θ	L1	M	φH
PS - 16	P30T - 1	12.5	16.5	43	11	7	45°	23	M12	2.5
PS - 17	P30T - 2						30°			
	P30T - 1(φ2.5)						45°			
PS - 1	P40T - 1	17	23	60	15	10	45°	35	M16	3
PS - 2	P40T - 2						30°			3(O-RING)
PS - 73	P40T - 1(φ3)						45°			3
PS - H28	P40T - 1HS						30°			
PS - 75	P40T - 2(φ3)						0°			
PS - 08	PS40 - 3F						29.6			
PS - G5	PS40 - 1F		54.6							
PS - G58	PS - G58		22	44.11	18.80	12.45	45°	19.11	M16	7
PS - G51	PS - G51									
PS - 805	PS - 805		23	54	19	14	15°	29	M16	6
PS - 806	PS - 806									
PS - P5	MP - 40	50								15
PS - 309	DIN69872 - A40	22.5	44.5	18.95	12.95	45°	16.4	M16	7	
PS - 302	DIN69872 - B40								54	19
PS - A1	ISO7388/2 - A40	25	37	65.2	28.97	20.83	45°	25.2	M24	
PS - A4	ISO7388/2 - B40						30°			
PS - 5	P50T - 1						45°			7
PS - 6	P50T - 2						30°			7(O-RING)
PS - 5E	P50T - 1(φ7)						45°			7
	P50T - 1HS						30°			
PS - 6E	P50T - 2(φ7)						0°			7(O-RING)
PS - 0	PS50 - 1F						7			
PS - H33	PS50 - 1FH									
	PS50 - 1F(φ7)									
PS - G45	PS - G45	38	85	23	17	45°	45	M24	10	
PS - G41	PS - G41									
PS - 809	PS - 809	37	65.2	28.97	20.83	45°	25.2	M24	10	
PS - 810	PS - 810									
PS - P	MP - 50	38	74	28	21	15°	34		10	
PS - B1	PS50 - 1L	36	71	24	18	0°	31			
PS - 512	DIN69872 - A50	38	110	22	16	30°	72			
PS - 581	DIN69872 - B50	36	74	28	21	15°	34	M24	11.5	
PS - A3	ISO7388/2 - A50									
PS - A6	ISO7388/2 - B50									
		37	65.5	29.1	19.6	45°	25.55		11.5	

- ▶ 사용할 기계의 풀스터드볼트 사양을 꼭 확인후 주문해 주십시오.
- ▶ Center Through 기계에 오일홀이 없는 풀스터드 볼트사용시에는 단면이 연마되어 있는 제품을 사용하셔야 합니다.
- ▶ Please order after checking specifications of pull stud bolt for Machining center.
- ▶ When you use pull stud bolt without oil hole at the center through machine you must use the pull stud bolt grinded face.

ACCESSORY PULL STUD BOLT

PULL STUD BOLT SPEC



장비 회사명	모델명	공구 형식	PSB	Oil Hole Type	장비 회사명	모델명	공구 형식	PSB	Oil Hole Type
DOOSAN	ACE-TC3200D	BT30	P30T-1	P40T-1(3)	SMEC	Any Mill LCV30A/B	BT30	P30T-2	
	ACE-TC400					Any Mill LCV55S		BT50	P50T-2
	ACE-HC400/500	Any Mill LCV650S	P50T-1	P50T-1		P50T-1(7)			
	ACE-HP4000/5100	Any Mill LCV66							
	ACE-V430	Any Mill LCV80							
	ACE-VC500	DMC-3000		P50T-1F		PS50-1FH			
	ACE-VM5410/510	BT40	JISB6339 B40 (PS-805)	P40T-1		P40T-1	P40T-1(3)		
	ACE-VM600								
	ACE-VMD450	BT50	P50T-1	P50T-1		P50T-1(7)			
	Mynx 410								
	Mynx NM410	SIRIUS-EON	SIRIUS-1	BT30	P30T-1				
	ACE-H100		SIRIUS-550	BT40	P40T-1	P40T-1(3)			
	ACE-HM500/630/800		SIRIUS-UL/ULG	BT50	PS50-1F	PS50-1FH			
	ACE-HP500/630		SIRIUS-12580						
	ACE-VM710		SIRIUS-650/650N						
	ACE-VM900/950		SIRIUS-700						
	Mynx 500		SIRIUS-7040						
	Mynx 650		SIRIUS-850/850N						
	Mynx 750		HASS	TM-1/2	BT40	P40T-1	P40T-1(3)		
	NR 510M			VF-4SS/3SS/2SS					
	NR 700	VF-2TR		BT50	P50T-1	P50T-1(7)			
	NR 5000	VF-5/50TR							
	VM 70(H)	VF-9/50							
VM 84	VF-8/50								
VM 925L	MAZZAK		BT40		PS-G51				
VM 560/50			BT50		PS-G41				
WA	MX 380/420	BT30	P30T-1		MORI SEKI		BT40	PS40-3F	
	VX 380T/420T						BT50	PS50-1F	PS50-1FH
	KV 45/45P	BT40	P40T-1	P40T-1(3)		S&T (구 통일)	FX-500H	BT40	P40T-2
	VX 400/460				TCH-45		P40T-1		P40T-1(3)
	VX 500				TNV-40A				
	VX 510M/660M				TNV-80A	BT50	P50T-2	P50T-2(7)	
	VX 700/40				TCH-50				
	VX 700/50	TCH-80							
	KV 60N/90	TCH80TS							
	VX 750	TNV-650V							
	WA500/50								

D'ANDREA®

TECHNOLOGY FOR HIGH PRECISION



Made in Italy



Marino D'Andrea, the founder
Marino D'Andrea, il fondatore



The first boring and facing head
La prima testa per sfacciare e alesare



Golden Compass
award for industrial design



The first D'Andrea logo type (1961)
Il primo logo tipo di D'Andrea (1961)

- Quality, Experience, Technology, High precision, Innovation, Professional skills are the strongest points that made the firm and the whole D'Andrea production winning on the Italian and the worldwide market.

- Qualità, Esperienza, Tecnologia, Alta precisione, Innovazione, Competenza, sono i punti di forza che hanno reso vincente l'azienda e tutta la produzione D'Andrea sul mercato nazionale ed internazionale.



- A tradition going back over 50 years in the field and a big passion for mechanics have been allowing D'Andrea to go on strengthening its position on domestic and international markets over the years. D'Andrea now has a 30% share of the market for modular systems and a 10% share of the entire toolholders sector (including modular systems), at the top in its sector in Italy. D'Andrea is internationally prominent in the field of large diameters precision boring.

- Una tradizione con più di 50 anni di attività nel settore e una grande passione per la meccanica hanno fatto sì che, nel corso degli anni, D'Andrea consolidasse sempre di più la sua posizione sul mercato nazionale ed internazionale. Attualmente D'Andrea detiene il 30% della quota di mercato dei sistemi modulari e il 10% nell'intero settore dei portautensili (comprensivo anche dei modulari) posizionandosi come leader nazionale. A livello internazionale, D'Andrea detiene la posizione di leadership nell'alesatura di precisione dei grandi diametri.

D'ANDREA MODULHARD'ANDREA

- INDEX
- INHALTSVERZEICHNIS
- ÍNDICE
- INDEX
- INDICE

- ARBORS
- GRUNDAUFNAHMEN
- ACOPLAMIENTOS BASE
- MANDRINS
- ATTACCHI BASE

- EXTENSIONS REDUCTIONS AND COOLANT FEED
- VERLÄNGERUNGEN, REDUZIERUNGEN UND KÜHLMITTELZUFUHR
- PROLONGACIONES REDUCCIONES Y CONDUCTORES PARA REFRIGERANTE
- RALLONGES-RÉDUCTIONS ET ADDUCTEURS ARROSAGE
- PROLUNGHE RIDUZIONI E ADDUTTORI REFRIGERANTE

- DOUBLE-BIT HEADS
- ZWEISCHNEIDERBOHRKÖPFE
- CABEZALES DE DOS CUCHILLAS
- TÊTES À DOUBLE TRANCHANT
- TESTINE BITAGLIANTI

p.240 • RFR



p.240 • TNT



p.63 • ISO 26623-1 PSC



p.64 • DIN 69871 FC



p.66-67 • DIN 69871



p.70 • ANSI/CAT



p.71 • ISO 50/60 D.60



p.71 • DIN 228/B 1806



p.72 • MR



p.61-62 • HSK DIN 69893



p.63 • ISO 26622-1 KM



p.65 • MAS 403 BT FC



p.68-69 • MAS 403 BT



p.70 • DIN 2080



p.71 • DIN 228/A 2207



p.71 • R8



p.72 • DIN 2079



p.72 • BR



p.73 • BMD



p.74 • PR



p.75 • RD



p.75 • RD



p.76 • RD



p.76 • RAV



p.77 • BLC



p.80-85 • TS . .
Ø 18 - 200



p.84-85 • SS . .



p.85 • PT



p.98-102-106-120-138 • PS 31



p.98-102-106-120-138 • CW 32

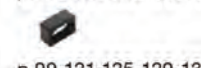

p.99-121-125-129-139 • P25



p.103-107 • P22



p.123-127-141-145 • P20.30



p.124-128-132-142-146 • PS



p.125-129-131-143-147 • P



p.97-101-105-111-113-119 • B . .
p.123-127-137-141-145



p.241 • KIT K20.50
Ø 6 - 30



• TESTAROSSA

p.88-91 • TRD 25-80
Ø 28 - 120



p.91 • SS. . - SF. .

p.92-95 • TRC 14-40
Ø 14.5 - 66



p.95 • SF. .

p.96-99 • TRC 50 • KIT K01
Ø 2.5 - 110 Ø 6 - 110



p.100-103 • TRC 63 • KIT K01
Ø 6 - 125 Ø 6 - 125



p.104-107 • TRC 80 • KIT K01
Ø 6 - 125 Ø 6 - 200



p.99-103-107 • SF. .



p.108-111 • TRC 32 HS • KIT K01
Ø 2.5 - 18 Ø 2.5 - 12



p.108-111 • TRM 32 HSB • KIT K01
Ø 2.5 - 18 Ø 2.5 - 12



p.112-113 • TRC 50 HS • KIT K01
Ø 2.5 - 22 Ø 6 - 22



p.112-113 • TRM 50 HSB • KIT K01
Ø 2.5 - 22 Ø 6 - 22



p.114-117 • TRM 16-40
Ø 18 - 63



p.117 • SF. .

p.118-121 • TRM 50 • KIT K01
Ø 2.5 - 108 Ø 6 - 108



p.122-125 • TRM 50/63 • TRM 63/63 • KIT K01
Ø 2.5 - 125 Ø 6 - 125



p.126-129 • TRM 50/80 • TRM 80/80 • KIT K01
Ø 2.5 - 160 Ø 6 - 220



p.130-133 • TRM 80/125 • KIT K01
Ø 36 - 500 Ø 36 - 410



p.134-139 • TR 50 PSC 40 • TR 50 PSC 50 • TR 50 PSC 63 • KIT K01
Ø 2.5 - 108 Ø 6 - 108



p.140-147 • TR 63 PSC 63 • TR 80 PSC 80 • KIT K01
Ø 2.5 - 160 Ø 6 - 220



p.121-125-129-133 • SF. .
p.139-143-147



p.148-153 • BPS
Ø 200 -2800



p.154 • TR 200
Ø 200 -2800



p.155 • SF. .

p.155 • SS. .



p.154 • CW p.154 • PRL



p.156 • TP p.156 • PC



p.157 • TU p.157 • AS..45°



p.158-159 • INSERT



p.160-161 • INFO



p.253 • Win Tool

- CHUCKING TOOLS
- ADAPTER
- ADAPTADORES
- ADAPTATEURS
- ADATTATORI

p.170 • PE



p.170 • MHD FORCE



p.171 • AW



p.172 • PF



p.173 • CM



p.174 • AM



p.174 • B16



p.174 • NS



p.175 • ACR/NC



p.175 • ACR



D'ANDREA MODULHARD'ANDREA

- WHAT IS MHD'?
- WAS IST DAS MHD'?
- ¿QUÉ ES EL MHD'?
- QU'EST-CE QUE LE MHD'?
- COS'È L'MHD'?



KR MHD는 매우 견고하고 유연성이 필요한 보링, 밀링, 드릴링, 탭핑 작업을 하는 머신닝센터에서 적합한 초정밀 모듈러 시스템을 틀 홀더입니다. 원통 모양과 원뿔 모양의 홀더의 연결은 11개 크기로 구성되어 있으며 basic arbor인 HSK, BT, DIN, 캡토 샹크, 익스텐션, 리덕션 그리고 아댑터를 포함한 모든 요소들을 호환하며 사용할 수 있습니다. 직경 2.5mm ~ 2800mm의 광범위한 보링작업은 MHD 라인을 가지고 황삭 작업과 2마이크론 미세 조정이 가능한 정삭 작업을 완벽하게 가공할 수 있습니다.

GB High precision modular toolholders for machine tools and machining centers that allow boring, milling, drilling, and tapping operations to be carried out with extreme flexibility and rigidity. The cylindrical-conical coupling comes in eleven, sizes, ensuring the interchangeability of all the elements of the system that includes the base arbors HSK, DIN, BT, CAT and Polygon-shank, toolholder extensions, reductions, and adapters. The broad boring program for machining diameters from 2.5 to 2800 mm completes the MHD' line with roughing double-bit heads and centesimal and micrometric Testarossa finishing heads with a 2µm sensitivity adjustment.

D Modulare Hochpräzisions-Werkzeughalter für Werkzeugmaschinen und Bearbeitungszentren, die mit extremer Flexibilität und Starre Ausbohr-, Fräs-, Bohr-, und Gewindebohrarbeiten ermöglichen. Die zylindrisch-konische Verbindung in elf Größen garantiert die Austauschbarkeit aller Elemente des Systems, das Basisanschlüsse HSK, DIN, BT und CAT und Polygon-shank Verlängerungen, Reduktionen und Adapter für Werkzeughalter mit einschließt. Das vielseitige Ausbohrprogramm zur Bearbeitung von Durchmessern von 2,5 bis 2800 mm, vervollständigt die Linie MHD' mit den zweiseitigen Grobbearbeitungsköpfen und den zentesimalen und mikrometrischen Feinbearbeitungsköpfen Testarossa mit einer Einstellfeinheit von 2µm.

E Portaherramientas modulares de alta precisión para máquinas herramientas y centros de mecanizado que permiten efectuar con extrema flexibilidad y rigidez, operaciones de mandrinado, fresado, taladrado y roscado. El acoplamiento cilíndrico-cónico disponible en once tamaños, garantiza la intercambiabilidad de todos los elementos del sistema, que incluye uniones base HSK, DIN, BT y CAT y Polygon-shank, prolongadores, reducciones y adaptadores portaherramientas. El amplio programa de mandrinado para la elaboración de diámetros de 2,5 a 2800 mm, completa la línea MHD' con los cabezales de desbaste de doble cuchilla y los cabezales de acabado centesimal y micrométricos Testarossa con sensibilidad de ajuste de 2µm.

I Portautensili modulari di alta precisione per macchine utensili e centri di lavoro che consentono di eseguire con estrema flessibilità e rigidità, operazioni di alesatura, fresatura, foratura e maschiatura. L'accoppiamento cilindrico-conico disponibile in undici grandezze, garantisce l'intercambiabilità di tutti gli elementi del sistema, che include attacchi base HSK, DIN, BT, CAT e Polygon-shank, prolunghe, riduzioni e adattatori portautensili. Il ricco programma di alesatura per la lavorazione di diametri da 2,5 a 2800 mm, completa la linea MHD' con le testine di sgrossatura bitaglianti e le testine di finitura centesimali e micrometriche Testarossa con sensibilità di regolazione di 2µm.



KR MHD의 연결은 밀링과 보링작업동안 최고의 견고함을 보증하기 때문에 MHD 툴링 시스템의 핵심입니다.
MHD 연결은 특허된 원기둥, 원뿔모양의 홀더의 연결 및 고정, 크램핑을 위한 원통 모양의 익스텐딩 볼트에 의해서 완성됩니다.

GB The MHD' coupling is the heart of the tool system as it ensures utmost rigidity and concentricity during milling and boring operations. This is achieved by the (patented) cylindrical-conical fit and by a radial expanding bolt for clamping and driving.

D Die MHD' Kupplung ist das Kernstück des MODULHARD'ANDREA, da sie maximale Starrheit und Konzentrizität beim Fräsen und Bohren sichert. Das wird durch die (patentiert) zylindrisch-konische Passfläche und den radialen Spreizbolzen für Axialspannung und Mitnahme erreicht.

E El acoplamiento MHD' es el punto de fuerza del MODULHARD'ANDREA, porque permite fresar y mandrinar con la máxima rigidez y concentricidad, gracias al acoplamiento (patentado) cilíndrico-cónico y al perno radial expansible para el bloqueo axial y el arrastre.

I L'attacco MHD' è il punto di forza del Modulhard'andrea perché consente di fresare ed alesare con massima rigidità e concentricità grazie all'accoppiamento (brevettato) cilindrico-conico e al perno radiale espandibile per il bloccaggio assiale e il trascinamento.

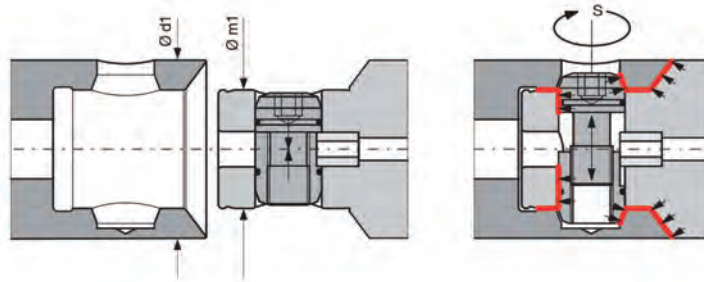

MHD'	Ø d1	Ø m1	S	Nm
MHD' 14	14	10	2,5	2 - 2,5
MHD' 16	16			
MHD' 20	20	13	3	4 - 4,5
MHD' 25	25	16	3	6,5 - 7,5
MHD' 32	32	20	4	7 - 8
MHD' 40	40	25	5	16 - 18
MHD' 50	50	32	6	30 - 35
MHD' 63	63	42	8	70 - 80
MHD' 80	80			
MHD' 110	110	76	14	200 - 220
MHD' 140	140			

- GENERAL INFORMATIONS
- ALLGEMEINES
- INFORMACIONES GENERALES
- GENERALITES
- INFORMAZIONI GENERALI

- KR** 1 툴 클램프에 기본 아바를 위치 시킨다.
2 구성품의 익스텐딩 핀이 돌출되지 않는 것을 확인하고 필요한 구성품(어댑터, 익스텐션, 보링헤드)을 아바에 넣는다.
3 제공된 렌치나 토크렌치로 익스텐딩 핀을 시계 방향으로 돌려서 완전히 고정시킨다.

GB Assembly: Secure the arbor to a rigid support. Fit the required component (adaptor, extension, boring head etc.) to the arbor ensuring that the radial expanding pin does not project from the cylindrical part. Clamp the component by turning the radial pin clockwise with the exagonal wrench provided or with a torque wrench. **Disassembly:** secure the arbor to a rigid support. Unlock the radial pin by turning it counterclockwise.

D Montage: Die Grundaufnahme in einer Halterung befestigen. Gewünschtes Komponente (Reduzierung, Verlängerun, Ausdrehkopf usw.) einsetzen. Darauf achten, dass der radiale Spreizbolzen nicht aus dem zylindrischen Teil heraus ragt. Element durch Rechtsdrehen des Spreizbolzens mit dem mitgelieferten Sechskantschlüssel oder einem Drehmomentschlüssel festklemmen. **Demontage:** Grundaufnahme in einer Halterung befestigen. Spreizbolzen durch Linksdrehen lösen.

E Montaje: Asegurar el acoplamiento base en un soporte. Montar el elemento deseado (reducción, prolongación, cabezal para mandrinar etc.) asegurándose que el perno radial no sobresalga del núcleo cilíndrico. Fijar girando en sentido horario el perno radial con la llave exagonal en dotación o con una llave torsiométrica. **Desmontaje:** Asegurar el acoplamiento base en un soporte. Desbloquear, girando a fondo en sentido antihorario, el perno radial.

I Montaggio: Assicurare l'attacco base in un supporto. Montare l'elemento desiderato (riduzione, prolunga, testina per alesare ecc.) assicurandosi che il perno radiale non sporga dal mozzo cilindrico. Bloccare ruotando in senso orario il perno radiale con la chiave esagonale in dotazione o con una chiave torsiométrica. **Smontaggio:** Assicurare l'attacco base in un supporto. Sbloccare, ruotando a fondo in senso antiorario, il perno radiale.

D'ANDREA MODULHARD'ANDREA

- ARBORS EXTENSIONS REDUCTIONS
- GRUNDAUFNAHMEN VERLÄNGERUNGEN REDUZIERUNGEN
- ACOPLAMIENTOS BASE PROLONGACIONES REDUCCIONES
- MANDRINS RALLONGES RÉDUCTIONS
- ATTACCHI BASE PROLUNGHE RIDUZIONI

KR 아바 D'ANDREA는 DIN69871 A-B, MAS 403BT, DIN 2080, ANSI-CAT, ISO 26623-1 등 모든 규격의 아바를 AT3 공차로 생산합니다. D'ANDREA는 직경 125mm 이상, 250mm 이상의 깊이의 홀가공시 MHD80, 110, 140 사용을 권장합니다. 익스텐션(EXTENSIONS) 다양한 길이의 익스텐션들은 가공 깊이에 따라 유연하게 적용할 수 있도록 각각의 MHD 규격에 연결하여 사용할 수 있습니다. 리덕션(REDUCTION) 작은 규격의 MHD 구성 요소들을 리덕션으로 연결하여 큰 규격의 구성요소들과 연결하여 사용할 수 있습니다.

GB **ARBORS.** Arbors are manufactured in accordance with DIN 69871 A-B, MAS 403 BT, DIN 2080, ANSI-CAT, DIN 69893-A, ISO 26623-1 and are made of carburized steel, hardened and ground to AT3 tolerance. Arbor sizes MHD' 80, 110 and 140 are recommended for heavy milling and for bores deeper than 250 mm and exceeding 125 mm diameter. Special arbors are available on request.

EXTENSIONS. Extensions of various lengths are available for each MHD' size, allowing greater flexibility in machining depth.

REDUCTIONS. MHD' components of a smaller size can be used by means of adaptor sleeves which allow greater interchangeability and ensure tool rigidity.

D **GRUNDAUFNAHMEN.** Die Grundaufnahmen entsprechen den Normen DIN 69871 A-B, MAS 403 BT, DIN 2080, ANSI-CAT, DIN 69893-A, ISO 26623-1. Sie werden aus Einsatzstahl gefertigt, gehärtet und auf Toleranz AT3 geschliffen. Für schwere Fräsarbeiten und Bohrungen mit Tiefen über 250 mm und Durchmesser über 125 mm ist der Einsatz von Grundaufnahmen Größe MHD' 80, 110 und 140 zweckmäßig. Grundaufnahmen in Sonderausführung sind auf Anfrage lieferbar.

VERLÄNGERUNGEN. Für jede MHD' Größe sind Verlängerungen verschiedener Länge vorhanden, die eine größere Anpassungsfähigkeit an die Bearbeitungstiefe ermöglichen.

REDUZIERUNGEN. Die Reduzierungen ermöglichen die Verwendung der Komponenten kleinerer MHD' Größen. Damit ist eine umfassende Austauschbarkeit und größere Steifigkeit gegeben.

E **ACOPLAMIENTOS BASE.** Los acoplamiento son realizados según las normas DIN 69871 A-B, MAS 403 BT, DIN 2080, ANSI-CAT, DIN 69893-A, ISO 26623-1 y son construidos en acero cementado, templado y rectificado según tabla AT3. El empleo de acoplamiento con tamaños MHD' 80, 110 y 140 son aconsejables para operaciones de fuerte fresado y para los mandrinados profundos, por encima de los 250 mm con diámetros superiores a 125 mm. A petición, se pueden construir acoplamiento especiales.

PROLONGACIONES. Para cada tamaño de MHD' existen prolongaciones de diferentes longitudes que permiten optimizar las profundidades de mecanización deseadas.

REDUCCIONES. Las reducciones permiten utilizar componentes de un tamaño MHD' más pequeño y, por lo tanto, tener mayor intercambiabilidad y estabilidad de la herramienta.

I **ATTACCHI BASE.** Gli attacchi sono realizzati secondo le norme DIN 69871 A-B, MAS 403 BT, DIN 2080, ANSI-CAT, DIN 69893-A, ISO 26623-1 e sono costruiti in acciaio cementato, temperato e rettificato secondo la tabella AT3. L'impiego di attacchi con grandezza MHD' 80, 110 e 140 sono consigliati per operazioni di fresatura pesante e per alesature profonde oltre i 250 mm con diametri superiori a 125 mm. A richiesta si possono costruire attacchi speciali.

PROLUNGHE. Per ogni grandezza di MHD' esistono prolunghe di differenti lunghezze che consentono di ottimizzare le profondità di lavorazione desiderate.

RIDUZIONI. Le riduzioni permettono di utilizzare componenti di una grandezza MHD' più piccola e quindi avere maggiore intercambiabilità e stabilità dell'utensile.



- ARBORS
- GRUNDAUFNAHMEN
- ACOPLAMIENTOS BASE
- MANDRINS
- ATTACCHI BASE

DIN 69893 HSK-A

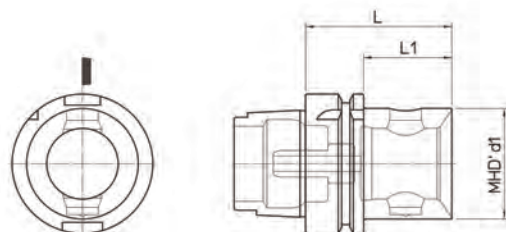

- Supplied with coolant tube
- Lieferung inklusive Kühlmittelrohr
- Completo con racor para el refrigerante
- Pourvu de raccord pour liquide d'arrosage
- Completo di raccordo per il refrigerante

HSK-A	REF.	CODE	MHD' d ₁	L	L ₁	kg
40	HSK-A40 MHD'32.48	41 6 32 15 040 20	32	48	28	0.4
50	HSK-A50 MHD'50.66	41 6 50 15 050 20	50	66	-	0.6
63	HSK-A63 MHD'40.60	41 6 40 15 063 20	40	60	34	0.7
	HSK-A63 MHD'50.66	41 6 50 15 063 20	50	66	40	0.9
80	HSK-A63 MHD'63.75	41 6 63 15 063 20	63	75	-	1.1
	HSK-A80 MHD'50.70	41 6 50 15 080 20	50	70	44	1.5
	HSK-A80 MHD'63.80	41 6 63 15 080 20	63	80	54	1.8
100	HSK-A80 MHD'80.86	41 6 80 15 080 20	80	86	-	2.1
	HSK-A100 MHD'50.72	41 6 50 15 100 20	50	72	43	2.4
	HSK-A100 MHD'63.82	41 6 63 15 100 20	63	82	53	2.7
	HSK-A100 MHD'80.88	41 6 80 15 100 20	80	88	59	3

DIN 69893 HSK-A

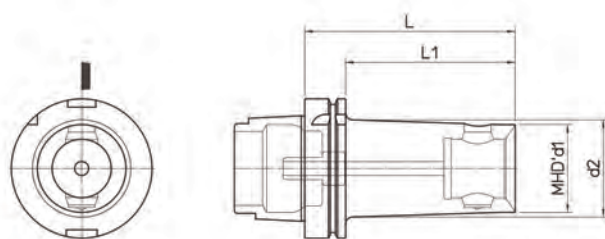

- Supplied with coolant tube
- Lieferung inklusive Kühlmittelrohr
- Completo con racor para el refrigerante
- Pourvu de raccord pour liquide d'arrosage
- Completo di raccordo per il refrigerante

HSK-A	REF.	CODE	MHD' d ₁	d ₂	L	L ₁	kg
63	HSK-A63 MHD'40.120	41 6 40 15 063 28	40	46	120	94	1.4
	HSK-A63 MHD'50.120	41 6 50 15 063 28	50	-			1.7
100	HSK-A100 MHD'50.120	41 6 50 15 100 28	50	60		91	3.2
	HSK-A100 MHD'63.150	41 6 63 15 100 28	63	70	121	4.5	
	HSK-A100 MHD'80.180	41 6 80 15 100 28	80	-	180	151	6.5

D'ANDREA MODULHARD'ANDREA

- ARBORS
- GRUNDAUFNAHMEN
- ACOPLAMIENTOS BASE
- MANDRINS
- ATTACCHI BASE

DIN 69893 HSK-A



- Supplied with coolant tube
- Lieferung inklusive Kühlmittelrohr
- Completo con racor para el refrigerante
- Pourvu de raccord pour liquide d'arrosage
- Completo di raccordo per il refrigerante

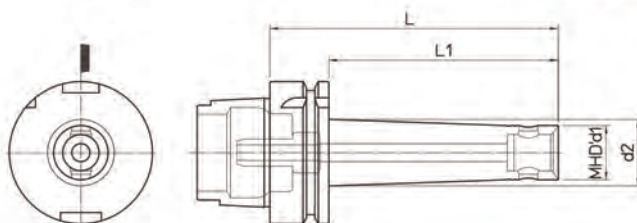

HSK-A	REF.	CODE	MHD' d ₁	d ₂	L	L ₁	kg
63	HSK-A63 MHD'16.63	41 6 16 06 563 20	16	17	63	37	0.7
	HSK-A63 MHD'16.100	41 6 16 10 563 20		19.5	100	74	0.8
	HSK-A63 MHD'20.63	41 6 20 06 563 20	20	-	63	37	0.6
	HSK-A63 MHD'20.90	41 6 20 09 563 20		22.5	90	64	0.8
	HSK-A63 MHD'20.125	41 6 20 12 563 20		25	125	99	0.9
	HSK-A63 MHD'25.63	41 6 25 06 563 20	25	-	63	37	0.7
	HSK-A63 MHD'25.90	41 6 25 09 563 20		27	90	64	0.9
	HSK-A63 MHD'25.125	41 6 25 12 563 20		29.5	125	99	1
	HSK-A63 MHD'32.90	41 6 32 09 563 20	32	33.5	90	64	1
	HSK-A63 MHD'32.125	41 6 32 12 563 20		36	125	99	1.2

DIN 69893 HSK-E



HSK-E	REF.	CODE	MHD' d ₁	L	L ₁	kg
40	HSK-E40 MHD'32.42	41 6 32 15 040 25	32	42	22	0.5
50	HSK-E50 MHD'50.66	41 6 50 15 050 25	50	66	-	0.6
63	HSK-E63 MHD'50.66	41 6 50 15 063 25			40	0.9

DIN 69893 HSK-F

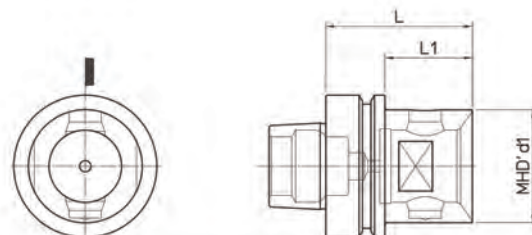

HSK-F	REF.	CODE	MHD' d ₁	L	L ₁	kg
63	HSK-F63 MHD'50.65	41 6 50 15 063 26	50	65	39	0.8



- ARBORS
- GRUNDAUFNAHMEN
- ACOPLAMIENTOS BASE
- MANDRINS
- ATTACCHI BASE

ISO 26623-1 PSC



fig.1

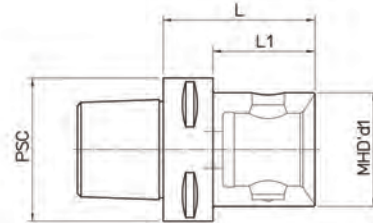
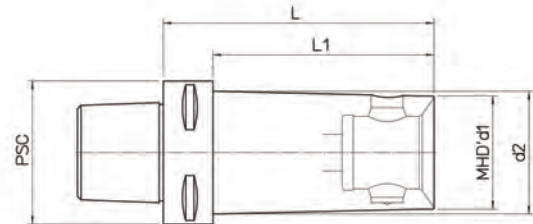
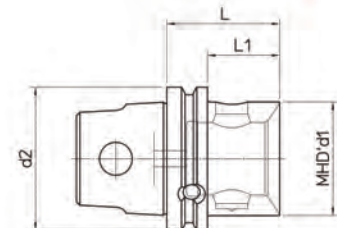

fig.2



PSC	REF.	CODE	MHD' d ₁	d ₂	L	L ₁	Kg.	fig.
40	PSC 40 - MHD' 32.42	41 6 32 26 040 04	32	-	42	22	0.3	1
	PSC 40 - MHD' 40.45	41 6 40 26 040 04	40		45	-	0.4	
50	PSC 50 - MHD' 50.55	41 6 50 26 050 05	50	-	55	-	0.8	1
63	PSC 63 - MHD' 40.50	41 6 40 26 063 05	40		44	50	28	
	PSC 63 - MHD' 40.120	41 6 40 26 063 12		50		-	55	33
	PSC 63 - MHD' 50.55	41 6 50 26 063 05	50		-		67	45
	PSC 63 - MHD' 50.67	41 6 50 26 063 06		50		54	120	98
	PSC 63 - MHD' 50.120	41 6 50 26 063 12	63		-		77	-
	PSC 63 - MHD' 63.77	41 6 63 26 063 07		63		-	77	-
80	PSC 80 - MHD' 50.60	41 6 50 26 080 06	50		-		60	30
	PSC 80 - MHD' 50.120	41 6 50 26 080 12		63		-	70	40
	PSC 80 - MHD' 63.70	41 6 63 26 080 07	63		67		150	120
	PSC 80 - MHD' 63.150	41 6 63 26 080 15		80		-	75	-
	PSC 80 - MHD' 80.75	41 6 80 26 080 07	80		-		120	-
	PSC 80 - MHD' 80.120	41 6 80 26 080 12		80		-	80	44
100	PSC 100 - MHD' 80.80	41 6 80 26 100 08	110		-		120	84
	PSC 100 - MHD' 110.120	41 6 91 26 100 12		110		-	120	84

ISO 26622-1 KM



KM	REF.	CODE	MHD' d ₁	d ₂	L	L ₁	kg
63	RD KM - MHD' 50.50	65 70 950 0506 3	50	63	50	32	0.8
	RD KM - MHD' 63.70	65 70 963 0506 3	63		70	-	1.2

D'ANDREA

D'ANDREA

MODULHARD'ANDREA

FACE CONTACT

- ARBORS
- GRUNDAUFNAHMEN
- ACOPLAMIENTOS BASE
- MANDRINS
- ATTACCHI BASE

DIN 69871 FC

FACE CONTACT AD+B

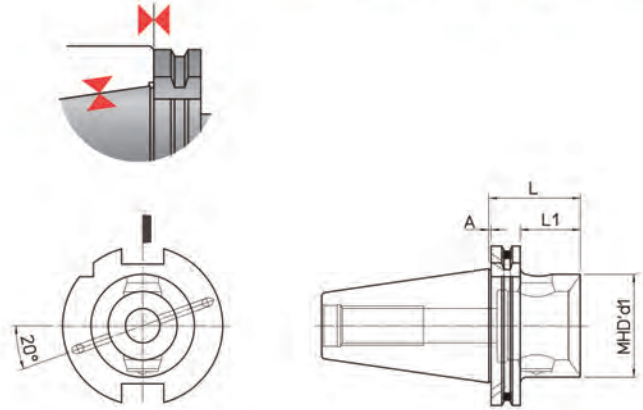

DIN	REF.	CODE	MHD' d1	A	L	L1	Kg.
40	DIN69871-AD+B40 FC MHD'50.48	41 6 50 01 040 21F	50	1	48	29	0.9
	DIN69871-AD+B40 FC MHD'63.80	41 6 63 01 040 21F	63		80	-	1.5
50	DIN69871-AD+B50 FC MHD'50.48	41 6 50 01 050 21F	50	1.5	48	29	2.5
	DIN69871-AD+B50 FC MHD'63.56	41 6 63 01 050 21F	63		56	37	2.8
	DIN69871-AD+B50 FC MHD'80.62	41 6 80 01 050 21F	80		62	43	3.4

DIN 69871 FC

FACE CONTACT AD+B

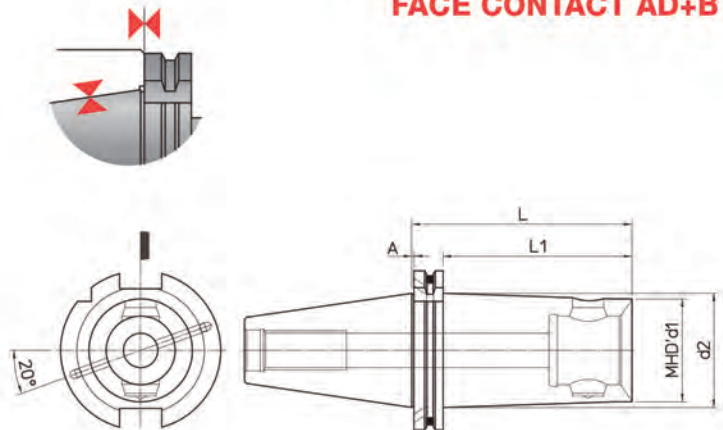

DIN	REF.	CODE	MHD' d1	d2	A	L	L1	Kg.
40	DIN69871-AD+B40 FC MHD'50.120	41 6 50 01 040 28F	50	-	1	120	101	1.7
	DIN69871-AD+B50 FC MHD'50.120	41 6 50 01 050 28F		59				3.5
50	DIN69871-AD+B50 FC MHD'50.200	41 6 50 01 050 27F	63	68	1.5	200	181	6.1
	DIN69871-AD+B50 FC MHD'63.150	41 6 63 01 050 28F		75.5				150
	DIN69871-AD+B50 FC MHD'63.250	41 6 63 01 050 27F	80	250		231	7.1	
	DIN69871-AD+B50 FC MHD'80.180	41 6 80 01 050 28F	80	-		180	161	6.9
	DIN69871-AD+B50 FC MHD'80.300	41 6 80 01 050 27F				300	281	9.2
	DIN69871-AD+B50 FC MHD'110.150	41 6 91 01 050 21F	110	-		150	-	7.6
	DIN69871-AD+B50 FC MHD'110.250	41 6 91 01 050 28F				250	-	9.5

D'ANDREA



- ARBORS
- GRUNDAUFNAHMEN
- ACOPLAMIENTOS BASE
- MANDRINS
- ATTACCHI BASE

MAS 403 BT FC FACE CONTACT AD+B

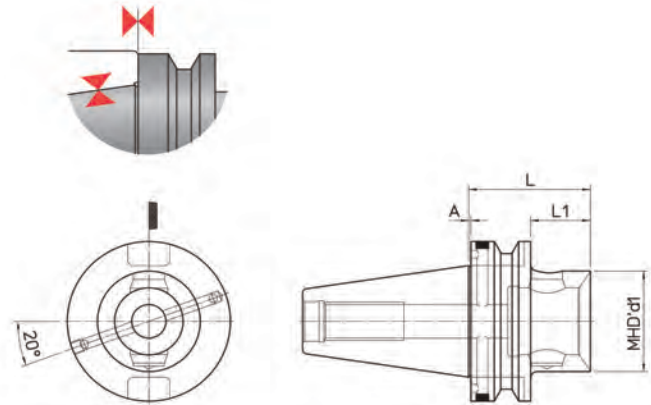

DIN	REF.	CODE	MHD' d ₁	A	L	L ₁	Kg.
40	MAS403 BT40 FC AD+B MHD'50.48	41 6 50 01 040 31F	50	1	48	21	0.9
	MAS403 BT40 FC AD+B MHD'63.66	41 6 63 01 040 31F	63		66	-	1.2
50	MAS403 BT50 FC AD+B MHD'50.66	41 6 50 01 050 31F	50	1.5	75	28	3.2
	MAS403 BT50 FC AD+B MHD'63.75	41 6 63 01 050 31F	63			37	3.7
	MAS403 BT50 FC AD+B MHD'80.75	41 6 80 01 050 31F	80			-	4

MAS 403 BT FC FACE CONTACT AD+B

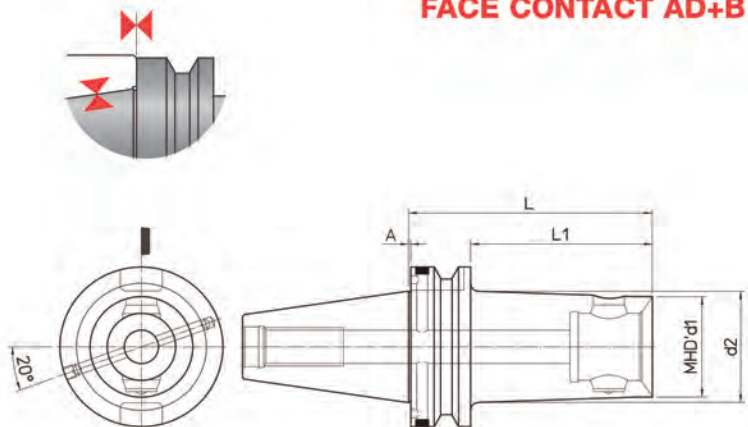

DIN	REF.	CODE	MHD' d ₁	d ₂	A	L	L ₁	Kg.
40	MAS403 BT40 FC AD+B MHD'50.120	41 6 50 01 040 38F	50	-	1	120	93	1.9
50	MAS403 BT50 FC AD+B MHD'50.120	41 6 50 01 050 38F		57.5			82	4.2
	MAS403 BT50 FC AD+B MHD'50.200	41 6 50 01 050 37F		66		200	162	4.5
	MAS403 BT50 FC AD+B MHD'63.150	41 6 63 01 050 38F	73.5	150	112	5.8		
	MAS403 BT50 FC AD+B MHD'63.250	41 6 63 01 050 37F	84	250	212	6.1		
	MAS403 BT50 FC AD+B MHD'80.180	41 6 80 01 050 38F	80	-	1.5	180	142	7.5
	MAS403 BT50 FC AD+B MHD'80.300	41 6 80 01 050 37F				300	262	9.2
	MAS403 BT50 FC AD+B MHD'110.150	41 6 91 01 050 31F				150	-	8.1
	MAS403 BT50 FC AD+B MHD'110.250	41 6 91 01 050 38F	110	-	-	250	-	9.5

- ARBORS
- GRUNDAUFNAHMEN
- ACOPLAMIENTOS BASE
- MANDRINS
- ATTACCHI BASE

MAS 403 BT

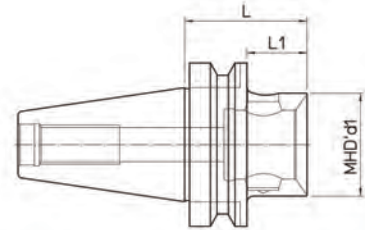
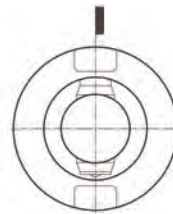

BT	REF.	CODE	MHD' d ₁	L	L ₁	kg
30	MAS403 BT30 MHD'32.32	41 6 32 01 030 30	32	32	10.5	0.5
	MAS403 BT30 MHD'40.35.5	41 6 40 01 030 30	40	35.5	14	0.6
	MAS403 BT30 MHD'50.60	41 6 50 01 030 30	50	60	-	0.7
35	MAS403 BT35 MHD'50.60	41 6 50 01 035 30			36	0.8
40	MAS403 BT40 MHD'40.45	41 6 40 01 040 30	40	45	18	0.6
	MAS403 BT40 MHD'50.38.5	41 6 50 01 040 39	50	38.5	11.5	0.8
	MAS403 BT40 MHD'50.48	41 6 50 01 040 30		48	21	0.9
	MAS403 BT40 MHD'50.56	41 6 50 01 040 80	56	29	1.1	
	MAS403 BT40 MHD'63.66	41 6 63 01 040 30	63	66	-	1.2
45	MAS403 BT45 MHD'50.62	41 6 50 01 045 30	50	62	29	1.7
	MAS403 BT45 MHD'63.70	41 6 63 01 045 30	63	70	37	2.3
	MAS403 BT45 MHD'80.70	41 6 80 01 045 30	80			2.7
50	MAS403 BT50 MHD'50.66	41 6 50 01 050 30	50	66	28	3.3
	MAS403 BT50 MHD'63.50	41 6 63 01 050 39	63	50	12	3.4
	MAS403 BT50 MHD'63.75	41 6 63 01 050 30		75	37	3.7
	MAS403 BT50 MHD'80.50	41 6 80 01 050 39	80	50	12	3.8
	MAS403 BT50 MHD'80.75	41 6 80 01 050 30		75	37	4
	MAS403 BT50 MHD'110.140	41 6 91 01 050 30	110	140	-	6.8
	MAS403 BT50 MHD'140.150	41 6 94 01 050 30	140	150	-	9.2
60	MAS403 BT60 MHD'110.110	41 6 91 01 060 30	110	110	63	11.5
	MAS403 BT60 MHD'110.200	41 6 91 01 060 38	140	200	152	18.1
	MAS403 BT60 MHD'140.100	41 6 94 01 060 30		100	52	12.9
	MAS403 BT60 MHD'140.250	41 6 94 01 060 38	250	202	30.1	

MAS 403 BT B

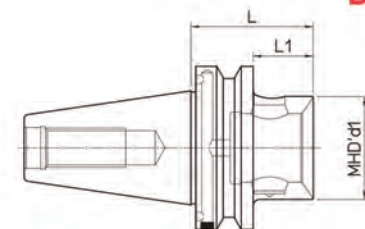
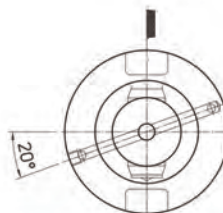

BT	REF.	CODE	MHD' d ₁	L	L ₁	kg
40	MAS403 BT40B MHD'50.48	41 6 50 01 040 31	50	48	21	0.9
	MAS403 BT40B MHD'63.66	41 6 63 01 040 31	63	66	-	1.2
50	MAS403 BT50B MHD'50.66	41 6 50 01 050 31	50	66	28	3.5
	MAS403 BT50B MHD'63.75	41 6 63 01 050 31	63	75	37	3.7
	MAS403 BT50B MHD'80.75	41 6 80 01 050 31	80			4



- ARBORS
- GRUNDAUFNAHMEN
- ACOPLAMIENTOS BASE
- MANDRINS
- ATTACCHI BASE

MAS 403 BT AD+B

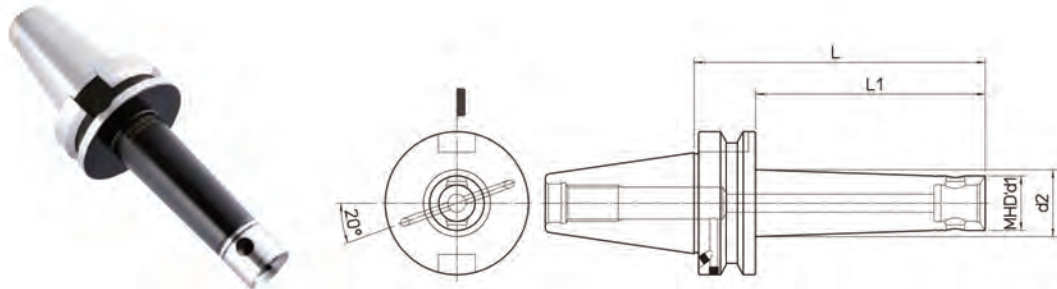

BT	REF.	CODE	MHD' d1	d2	L	L1	kg
40	MAS403 BT40-AD+B MHD'16.45	41 6 16 04 140 31	16	-	45	18	0.8
	MAS403 BT40-AD+B MHD'16.63	41 6 16 06 140 31		17	63	36	0.9
	MAS403 BT40-AD+B MHD'16.100	41 6 16 10 140 31		19.5	100	73	1
	MAS403 BT40-AD+B MHD'20.50	41 6 20 05 140 31	20	-	50	23	0.9
	MAS403 BT40-AD+B MHD'20.80	41 6 20 08 140 31		22	80	53	1
	MAS403 BT40-AD+B MHD'20.125	41 6 20 12 140 31		25	125	98	1.1
	MAS403 BT40-AD+B MHD'25.50	41 6 25 05 140 31	25	-	50	23	1
	MAS403 BT40-AD+B MHD'25.80	41 6 25 08 140 31		26.5	80	53	1.1
	MAS403 BT40-AD+B MHD'25.125	41 6 25 12 140 31		29.5	125	98	1.2
	MAS403 BT40-AD+B MHD'32.50	41 6 32 05 140 31	32	-	50	23	1.1
	MAS403 BT40-AD+B MHD'32.80	41 6 32 08 140 31		33	80	53	1.2
	MAS403 BT40-AD+B MHD'32.125	41 6 32 12 140 31		36	125	98	1.4

MAS 403 BT AD+B

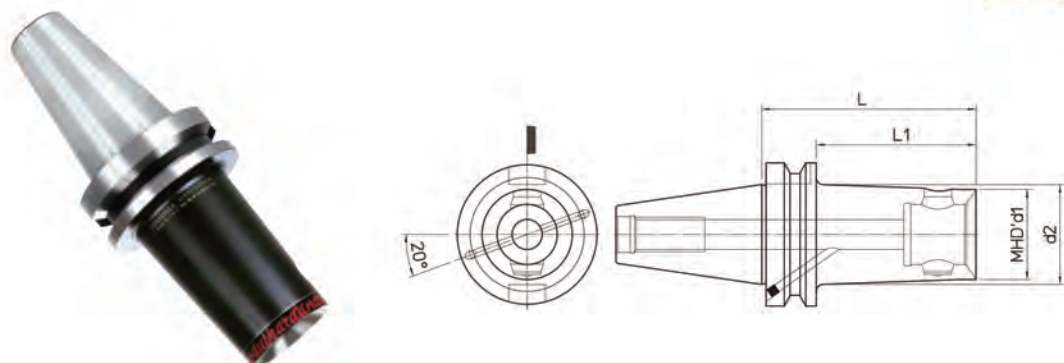

BT	REF.	CODE	MHD' d1	d2	L	L1	kg
40	MAS403 BT40-AD+B MHD'40.120	41 6 40 01 040 38	40	44.5	120	93	0.9
	MAS403 BT40-AD+B MHD'50.120	41 6 50 01 040 38	50	-			1.9
50	MAS403 BT50-AD+B MHD'50.120	41 6 50 01 050 38		63	60	150	112
	MAS403 BT50-AD+B MHD'63.150	41 6 63 01 050 38	70		5.8		
	MAS403 BT50-AD+B MHD'80.180	41 6 80 01 050 38	80	-	180	142	7.5

D'ANDREA MODULHARD'ANDREA

- ARBORS
- GRUNDAUFNAHMEN
- ACOPLAMIENTOS BASE
- MANDRINS
- ATTACCHI BASE

ANSI/CAT

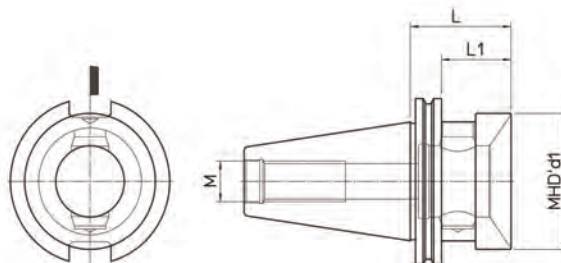

ANSI/CAT	REF.	CODE	MHD' d1	L	L1	M	kg
40	ANSI/CAT40 MHD'50.66	41 6 50 01 040 40	50	66	47	M16	1.1
	ANSI/CAT40 MHD'63.100	41 6 63 01 040 40	63	100	-		1.9
45	ANSI/CAT45 MHD'50.48	41 6 50 01 045 40	50	48	29	M20	1.7
	ANSI/CAT45 MHD'63.75	41 6 63 01 045 40	63	75	56		2.1
	ANSI/CAT45 MHD'80.80	41 6 80 01 045 40	80	80	-		2.7
50	ANSI/CAT50 MHD'50.48	41 6 50 01 050 40	50	48	29	M24	2.4
	ANSI/CAT50 MHD'63.56	41 6 63 01 050 40	63	56	37		2.9
	ANSI/CAT50 MHD'80.62	41 6 80 01 050 40	80	62	43		3.2

DIN 2080-A 'OTT'

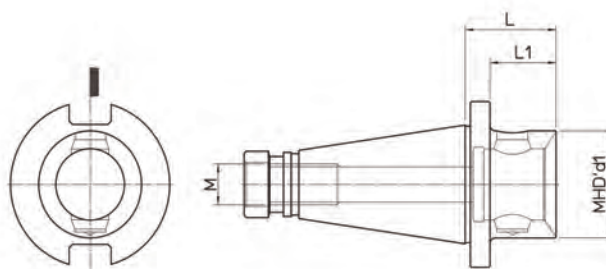

ISO	REF.	CODE	MHD' d1	L	L1	M	kg
30	DIN2080-A30 MHD'50.58	41 6 50 01 030 00	50	58	-	M12	0.6
40	DIN2080-A40 MHD'50.48	41 6 50 01 040 00	50	48	36.5	M16	0.9
	DIN2080-A40 MHD'63.60	41 6 63 01 040 00	63	60	-		1.2
45	DIN2080-A45 MHD'50.48	41 6 50 01 045 00	50	48	33	M20	1.6
	DIN2080-A45 MHD'63.60	41 6 63 01 045 00	63	60	45		1.9
	DIN2080-A45 MHD'80.66	41 6 80 01 045 00	80	66	-		2.2
50	DIN2080-A50 MHD'50.48	41 6 50 01 050 00	50	48	33	M24	2.6
	DIN2080-A50 MHD'63.56	41 6 63 01 050 00	63	56	41		2.7
	DIN2080-A50 MHD'80.60	41 6 80 01 050 00	80	60	45		3.2



- ARBORS
- GRUNDAUFNAHMEN
- ACOPLAMIENTOS BASE
- MANDRINS
- ATTACCHI BASE

ISO 50 D.60
ISO 60 D.60

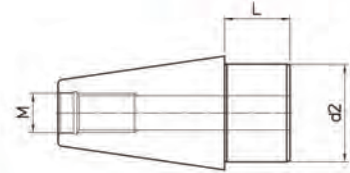

REF.	CODE	d2	L	M	Kg.
ISO 50 D.60	71ISO-50-DC6040	60	40	24	4.8
ISO 60 D.60	71ISO-60-DC6040			30	9.7

DIN 228/A 2207

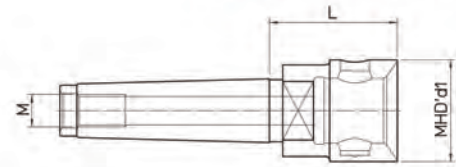
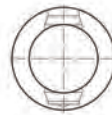

MORSE	REF.	CODE	MHD' d ₁	L	M	kg
4	MORSE4-A MHD'50.63	41 6 50 03 004 00	50	63	M16	0.9
4 SIP	MORSE4-A SIP MHD'50.63	41 6 50 03 004 01			M14	

DIN 228/B 1806

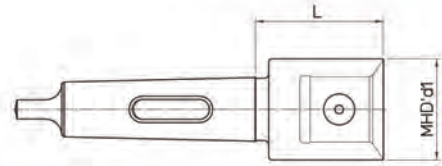
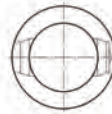

MORSE	REF.	CODE	MHD' d ₁	L	kg
4	MORSE4-B MHD'50.56	41 6 50 02 004 00	50	56	0.9
5	MORSE5-B MHD'63.65	41 6 63 02 005 00	63	65	1.5

R8

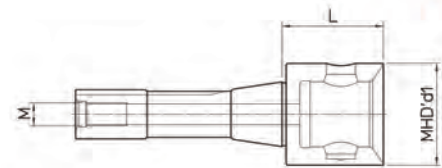

REF.	CODE	MHD' d ₁	L	M	kg
R 8	41 6 50 05 008 00	50	50	M12x1.75	0.8

D'ANDREA MODULHARD'ANDREA

- ARBORS
- GRUNDAUFNAHMEN
- ACOPLAMIENTOS BASE
- MANDRINS
- ATTACCHI BASE



REF.	CODE	MHD' d1	L	L1	d2	kg	fig.
BR 16/16.100	65 70 816 0100 1	16	100	-	16	0.15	1
BR 20/20.125	65 70 820 0125 1	20	125	-	20	0.3	
BR 25/32.35	41 6 32 08 025 00	32	100	35	25	0.7	2
BR 32/50.60	41 6 50 08 032 00	50	140	60	32	1	

MR

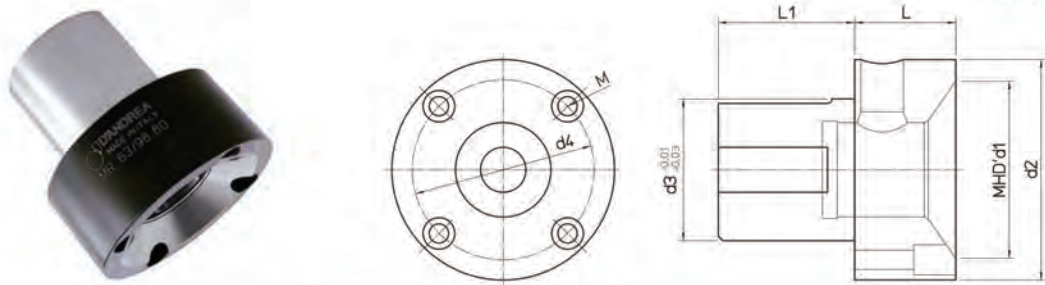

REF.	CODE	MHD' d1	d2	d3	d4	L	L1	M	kg
MR 50/80.80	45 02 080 0106 0	63 ~ 80	80	50	65	45	50	M6	1.5
MR 63/98.80	45 02 098 0106 0		98	63	80		60	M8	3.1
MR 80/130.80	45 02 130 0124 0		130	80	104.6		80	M10	6.1

DIN 2079

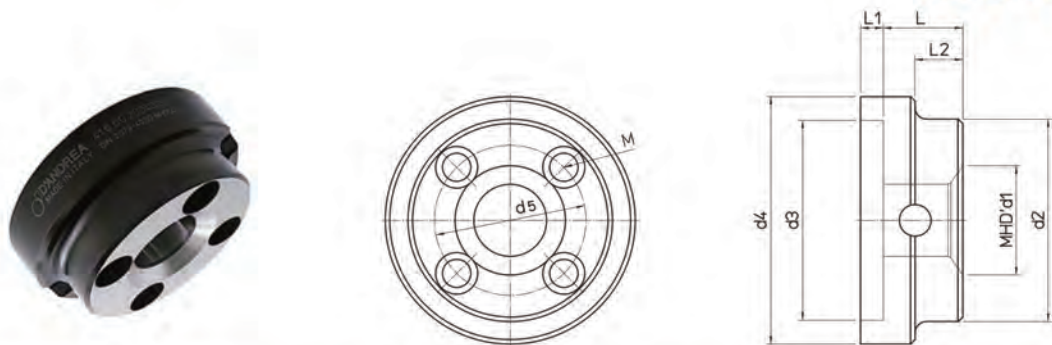

REF.	CODE	MHD' d1	d2	d3	d4	d5	L	L1	L2	M	kg
DIN 2079-40.50	41 6 50 20 040 00	50	90	88.89	110	66.7	35	10	21	M12	1.8
DIN 2079-40.63	41 6 63 20 040 00	63					47		31		2
DIN 2079-50.63	41 6 63 20 050 00	63					45		M16	5.4	
DIN 2079-50.80	41 6 80 20 050 00	80	135	128.57	150	101.6	50	36		5.3	
DIN 2079-50.110	41 6 91 20 050 00	110					112	98		8.4	
DIN 2079-50.140	41 6 94 20 050 00	140					140	122		108	9.5



- CARBIDE BARS FOR DEEP-HOLE MACHINING
- HARTMETALL-BOHRSTANGENFÜR TIEFLOCH-BEARBEITUNGEN
- BARRAS DE METAL DURO PARA MECANIZACIONES DE AGUJEROS PROFUNDOS
- BARRES CARBURE POUR USINAGES DE TROUS PROFONDS
- BARRE IN METALLO DURO PER LAVORAZIONI DI FORI PROFONDI

BMD PROGRAM

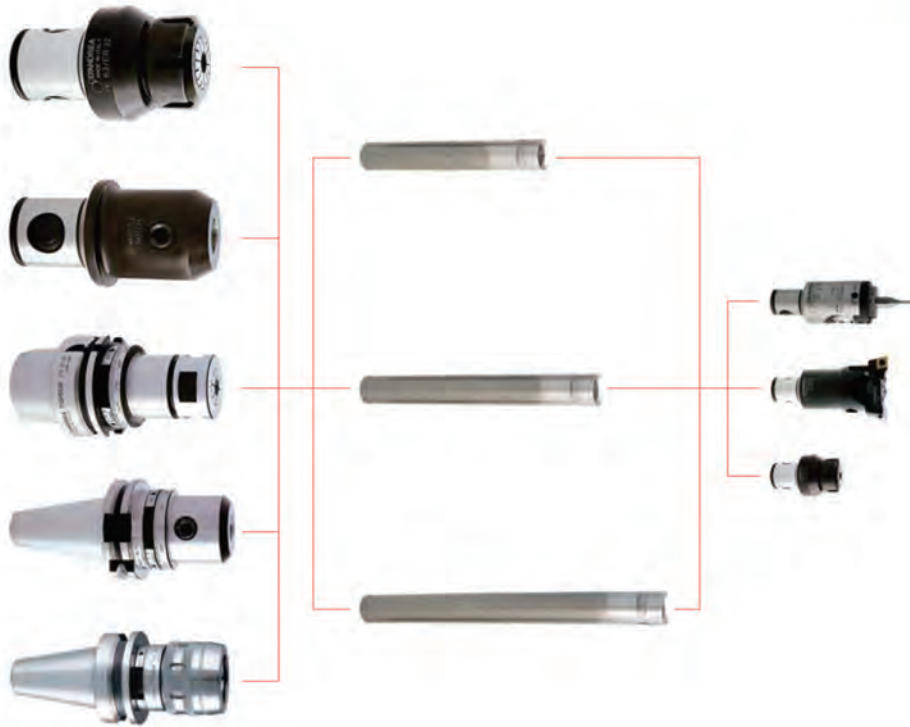

BMD



REF.	CODE	MHD' d1	d2	L	L1	kg
BMD 16/16.110	65 70 816 0110 5	16	16	110	50	0.3
BMD 16/16.140	65 70 816 0140 5			140	63	0.4
BMD 16/16.170	65 70 816 0170 5			170	80	0.5
BMD 20/20.135	65 70 820 0135 5	20	20	135	63	0.6
BMD 20/20.170	65 70 820 0170 5			170	80	0.75
BMD 20/20.210	65 70 820 0210 5			210	100	0.9
BMD 25/25.160	65 70 825 0160 5	25	25	160	80	1
BMD 25/25.205	65 70 825 0205 5			205	100	1.3
BMD 25/25.255	65 70 825 0255 5			255	125	1.6
BMD 32/32.195	65 70 832 0195 5	32	32	195	100	2.1
BMD 32/32.250	65 70 832 0250 5			250	125	2.8
BMD 32/32.315	65 70 832 0315 5			315	160	3.5

D'ANDREA

MODULHARD'ANDREA

- REDUCTIONS
- REDUZIERUNGEN
- REDUCCIONES
- RÉDUCTIONS
- RIDUZIONI

RD

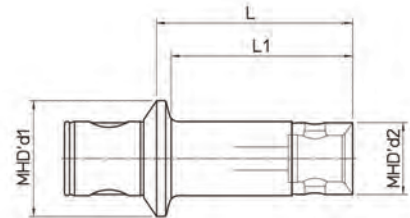

REF.	CODE	MHD' d1	MHD' d2	L	L1	kg
RD 50/16.40	65 70 050 0016 2	50	16	40	32	0.2
RD 50/16.74	65 70 050 0016 3			74	65	0.25
RD 50/20.70	65 70 050 0020 2		20	70	62	0.3
RD 50/20.93	65 70 050 0020 3			93	85	0.35
RD 50/25.87	65 70 050 0025 2		25	87	80	0.6
RD 50/25.117	65 70 050 0025 3			117	110	0.65
RD 50/32.87	65 70 050 0032 2		32	87	80	0.75
RD 50/32.144	65 70 050 0032 3			144	137	1
RD 50/40.87	65 70 050 0040 2		40	87	80	0.9
RD 50/40.176	65 70 050 0040 3			176	170	1.8

- VIBRATION-DAMPING REDUCTIONS
- VIBRATIONSARME REDUZIERUNGEN
- REDUCCIONES ANTI-VIBRACIÓN
- RÉDUCTIONS ANTI-VIBRATOIRES
- RIDUZIONI ANTIVIBRANTI

RAV

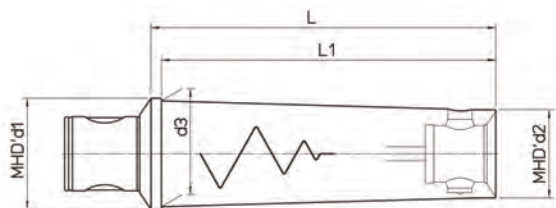

REF.	CODE	MHD' d1	MHD' d2	d3	L	L1	kg
RAV 50/16.74	65 70 050 0016 5	50	16	17.5	74	65	0.4
RAV 50/20.93	65 70 050 0020 5		20	21.5	93	85	0.5
RAV 50/25.117	65 70 050 0025 5		25	27	117	110	0.8
RAV 50/32.144	65 70 050 0032 5		32	35	144	138	1.4
RAV 50/40.176	65 70 050 0040 5		40	47	176	170	2.5
RAV 63/50.220	65 70 063 0050 5	63	50	60	220	214	5.6
RAV 80/63.280	65 70 080 0063 5	80	63	77	280	272	10.6



- BALANCING RINGS
- AUSWUCHTRINGE
- ANILLOS DE EQUILBRADO
- BAGUES D'ÉQUILIBRAGE
- ANELLI DI BILANCIATURA

BLC

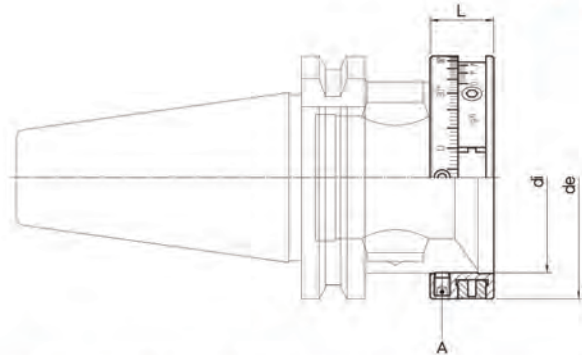

REF.	CODE	MHD'	de	di (G6)	L
BLC 42.32	38 17 25 032 001	32	42	31.5	14
BLC 50.40	38 17 25 040 001	40	50	39.5	15
BLC 63.50	38 17 25 050 001	50	63.5	49.8	16
BLC 80.63	38 17 25 063 001	63	80	62.8	18

KR BLC 바란스 링은 눈금을 가진 두개의 평행추로 셋팅하여 사용 됩니다. 바란스 링 사용을 사용함으로써 동심도 및 정삭 조도 향상, 툴 라이프 향상의 장점을 가지며 가공시 공구 진동을 최소화 하여 머신닝 센터의 스피들 베어링을 보호할 수 있습니다.

※ 조립 방법 : 아바의 플라스틱 링을 제거하고 BLC 바란스 링을 삽입후 나사로 조여주십시오.

GB The BLC balancing ring, only by setting the two incorporated graduated counterweights, allows to balance, in an accurate and economical way, the toolholder on which it is mounted. The use of the BLC ring provides the following advantages: improved accuracy and surface finish; considerable extension of tool life; considerable extension of spindle bearings life; drastic reduction of vibrations and noise level in the machining centre.

ASSEMBLY: Remove the plastic guard ring; insert the BLC ring and lock the A screws.

D Der Auswuchtring BLC mit integrierten und beweglichen Gewichten ermöglicht es, den Werkzeughalter, an dem der Ring montiert ist, genau und wirtschaftlich auszuwuchten. Die Verwendung des BLC Auswuchtrings an Werkzeughaltern bietet folgende Vorteile: verbesserte Genauigkeit und Oberflächenfertigung (Qualität); merkbar höhere Lebensdauer der Werkzeuge und Schneidwerkzeuge; Schonung der Spindellager, dadurch deutlich höhere Lebensdauer; erhebliche Verminderung von Vibrationen und Geräuschen am Arbeitsplatz.

MONTAGE: Schutzring aus Kunststoff entfernen; Auswuchtring BLC einsetzen und Schrauben A spannen.

E El anillo de equilibrado BLC, con el simple posicionamiento de los dos contrapesos graduados incorporados, permite equilibrar, en forma precisa y económica, el portaherramientas en el cual va montado. La utilización del anillo BLC da las siguientes ventajas: mejora la precisión y la calidad de las superficies mecanizadas; aumenta la duración de la herramienta; prolonga la vida del husillo del centro de mecanizado; reduce las vibraciones y la rumorosidad del centro de mecanizado.

MONTAJE: Quitar el anillo de protección de plástico; insertar anillo BLC y fijar los tornillos A.

I L'anello di bilanciatura BLC, con il semplice posizionamento dei due tasselli graduati incorporati, permette di equilibrare, in modo preciso ed economico, il portautensile nel quale lo stesso viene montato. L'utilizzo dell'anello BLC dà i seguenti vantaggi: migliora la precisione e la qualità delle superfici lavorate; aumenta la durata dell'utensile; allunga la vita del mandrino del centro di lavoro; riduce le vibrazioni e la rumorosità del centro di lavoro.

MONTAGGIO: Togliere l'anello di protezione in plastica; inserire l'anello BLC e bloccare le viti A.

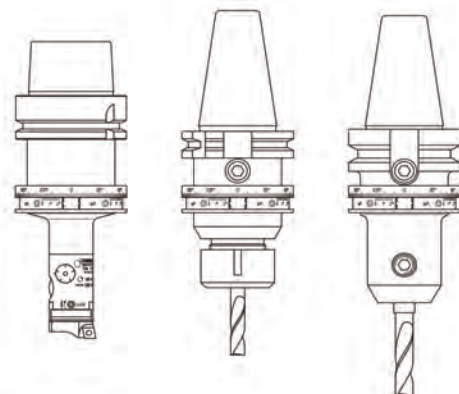
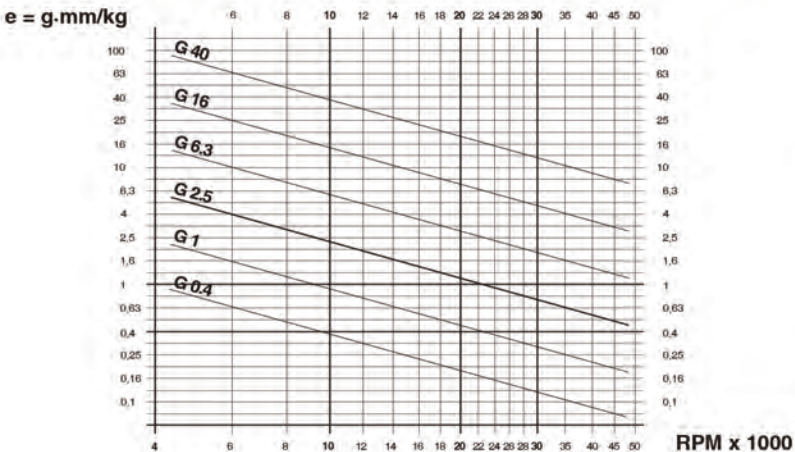

D'ANDREA

testarossad'andrea

TS

TRD

TRC

TRC HS

			p. 94 • TRC 14 Ø 14.5 - 18		
p.82 • TS 16/16 Ø 18 - 22			p. 94 • TRC 16 Ø 18 - 24		p.116 • TRM 16 Ø 18 - 23
p.82 • TS 20/20 Ø 22 - 28			p. 94 • TRC 20 Ø 22 - 30		p.116 • TRM 20 Ø 22 - 29
p.82 • TS 25/25 Ø 28 - 38		p.90 • TRD 25 Ø 28 - 36	p.94 • TRC 25 Ø 28 - 40		p.116 • TRM 25 Ø 28 - 38
p.82 • TS 32/32 Ø 35.5 - 50		p.90 • TRD 32 Ø 36 - 46	p.94 • TRC 32 Ø 35 - 53	p.110 • TRC 32 HS Ø 2.5 - 18	p.116 • TRM 32 Ø 35.5 - 50
p.82 • TS 40/40 Ø 50 - 68		p.90 • TRD 40 Ø 46 - 60	p.94 • TRC 40 Ø 48 - 66		p.116 • TRM 40 Ø 48 - 63
p.83 • TS 50/50 Ø 68 - 90	p.83 • TS 50/63 Ø 90 - 120	p.90 • TRD 50 Ø 60 - 75	p.96 • TRC 50 Ø 2.5 - 110	p.112 • TRC 50 HS Ø 2.5 - 22	p.118 • TRM 50 Ø 2.5 - 108
p.83 • TS 63/63 Ø 90 - 120		p.90 • TRD 63 Ø 75 - 95	p.100 • TRC 63 Ø 72 - 125		
p.83 • TS 80/80 Ø 120 - 200		p.90 • TRD 80 Ø 95 - 120	p.104 • TRC 80 Ø 88 - 200		

D'ANDREA



BORING SYSTEM

TRM
2μm

TRM HSB
2μm



INSERTS

p.110 • **TRM 32 HSB**
Ø 2.5 ~ 18



p.122 • **TRM 50/63** p.126 • **TRM 50/80** p.112 • **TRM 50 HSB**
Ø 6 ~ 125 Ø 6 ~ 160 Ø 2.5 ~ 22



p.122 • **TRM 63/63**
Ø 6 ~ 125



p.126 • **TRM 80/80** p.130 • **TRM 80/125**
Ø 6 ~ 160 Ø 36 ~ 500



BPS

p.154 • **TR 200**
2μm

p.150-151 • **BPS 200 - 800**
Ø 200 - 1200

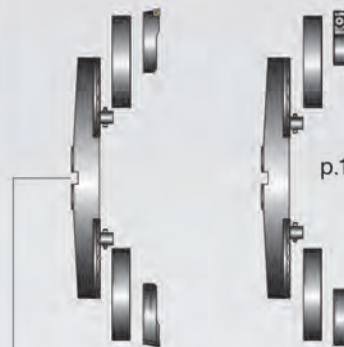

p.154 • **TR 200**
2μm

p.152-153 • **BPS 1000 - 1600**
Ø 1000 - 2800

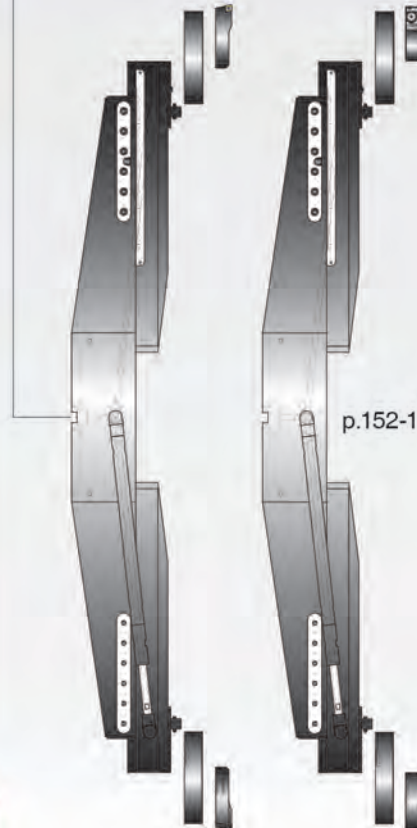

D'ANDREA

D'ANDREA MODULHARD'ANDREA

TS Ø 18 ~ 200

- DOUBLE-BIT HEADS
- ZWEISCHNEIDERBOHRKÖPFE
- CABEZALES DE DOS CUCHILLAS
- TÊTES À DOUBLE TRANCHANT
- TESTINE BITAGLIANTI



- 1**
- Body
 - Körper
 - Cuerpo
 - Corps
 - Corpo
- 2**
- Setting screws
 - Einstellschraube
 - Tornillo de regulación
 - Vis de réglage
 - Vite di regolazione

- 3**
- Expanding pin
 - Spreizbolzen
 - Perno radial expansible
 - Tige radiale expansible
 - Perno radiale espandibile
- 4**
- Coolant outlets
 - Kühlmittelaustritt
 - Agujeros salida refrigerante
 - Sortie du liquide d'arrosage
 - Fori uscita refrigerante
- 5**
- Bit holders
 - Plattenhalter
 - Portaplaquita
 - Porte-plaquettes
 - Seggio portainseriti
- 6**
- Tools clamp screws
 - Werkzeugklemmschrauben
 - Tornillos bloqueaje herramienta
 - Vis blocage outil
 - Viti bloccaggio utensile

KR DOUBLE-BIT HEAD는 조립이 용이하고 클램핑 나사와 커터 사이의 일정한 간격을 두고 bit holder 와 insert 홀더 그리고 헤드와 일정한 간격으로 세레이션된 면끼리의 조립으로 인하여 매우 견고합니다.

GB The double-bit heads are easy and extremely rigid thanks to the extensive area serrated with contacts between the bit holder and upper insert holder and the heads, together with the constant distance between the seat of the clamping screws and the cutter.

D Die Zweischniderköpfe sind aufgrund des einfachen Aufbaus und der großen, verzahnten Kontaktfläche zwischen Plattenhalter und Kopf zusammen mit dem gleichbleibenden Abstand zwischen Wendepaltensitz und Plattenhalterklemmung extrem stabil.

E Los cabezales de dos cuchillas son sencillos y extremamente rígidos gracias a las amplias superficies dentadas de contacto entre los asientos porta-plaquetas y los cabezales mismos, así como a la distancia constante entre los tornillos de sujeción del asiento y el filo de corte.

I Le testine bitaglienti sono semplici ed estremamente rigide grazie alle ampie superfici dentellate di contatto tra i seggi portainserito e le testine stesse, unitamente alla distanza costante tra la vite di serraggio del seggio ed il tagliente.

D'ANDREA

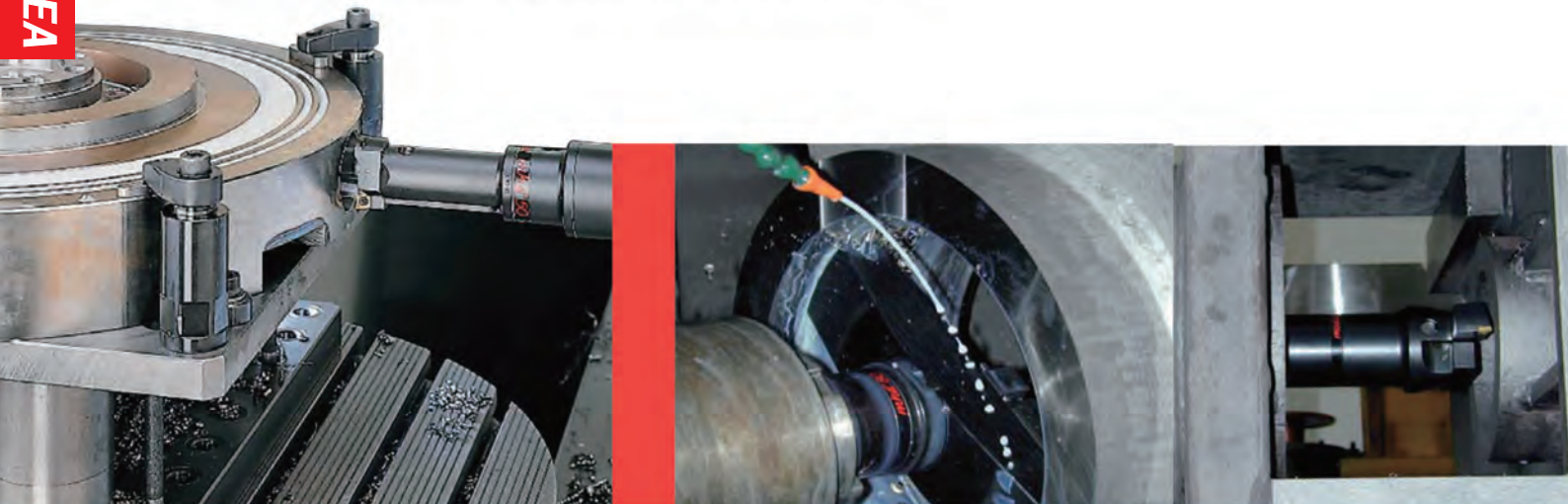

TS Ø 18 ~ 200

- DOUBLE-BIT HEADS
- ZWEISCHNEIDERBOHRKÖPFE
- CABEZALES DE DOS CUCHILLAS
- TÊTES À DOUBLE TRANCHANT
- TESTINE BITAGLIENTI

KR Cutting edge 들의 Radial setting은 툴 프리셋터에서 해야 합니다. TS 보링바에는 두꺼운 chip 제거에 관련된 황삭 작업을 위해 두개의 bit holder를 조립합니다.

GB USE. The radial setting of the cutting edges should be carried out with tool presetting equipment. The boring bars are fitted with two bit holders for roughing operations involving heavy chip removal. The double-bit boring bars may include:

D EINSATZ. Die Durchmessereinstellung der Wendeplatten ist auf einem Maschinenwerkzeug-voreinstellgerät vorzunehmen. Mit zwei Plattenhaltern werden die Köpfe für Schrupparbeiten mit starker Spanabnahme verwendet. Diese Köpfe können umfassen:

E EMPLEO. La regulación diametral de los cortes se efectúa sobre un banco presetting para herramientas. Se utilizan con dos asientos para operaciones de desbaste con fuerte arranque de viruta. Los cabezales de dos cuchillas pueden estar compuestos con:

I IMPIEGO. La regolazione diametrale dei taglienti va eseguita su un banco di presetting di utensili. Si utilizzano con due seggi per operazioni di sgrossatura con forti asportazioni. I barení bitaglianti possono essere composti con:

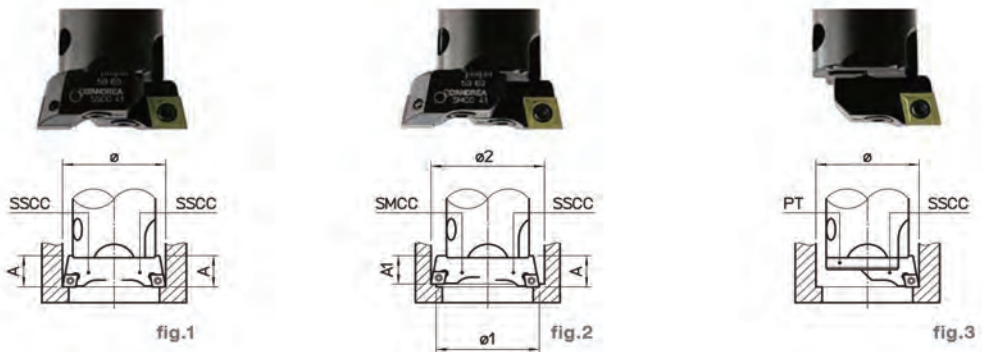

fig. 1 KR 두개의 cutting edge가 동일한 높이 및 동일한 Radial 거리로 셋팅되는 두개의 SSCC bit holder 사용은 빠른 황삭 작업을 위해 사용합니다.

GB two SSCC bit holders on the same plane and with the two cutting edges set at identical radial distance for high feed rate roughing operations.

D zwei Plattenhalter SSCC auf gleicher Höhe mit der Schneidkante der Wendeplatten auf gleichem Durchmesser einstellen. Für Schrupparbeiten mit großem Vorschub.

E dos asientos SSCC alineados y con la punta de la plaquita sobre el mismo diámetro para operaciones de desbaste con fuertes avances.

I due seggi SSCC allineati e con la punta degli inserti sullo stesso diametro per operazioni di sgrossatura con forti avanzamenti.

fig. 2 KR 두개의 cutting edge가 서로 상이한 높이 및 Radial 거리로 셋팅 되는 한 개의 SSCC bit holder와 한 개의 SMCC bit holder 사용은 깊은 홀의 빠른 황삭 작업을 위해 사용합니다.

GB an SSCC bit holder and an SMCC bit holder not at the same plane and with the two cutting edges set at different radial distances for high cutting depth roughing operations.

D je einen Plattenhalter SSCC und SMCC auf verschiedener Höhe mit der Schneidkante der Wendeplatten auf verschiedenem Durchmesser einstellen für Schrupparbeiten mit großer Spantiefe.

E un asiento SSCC y un asiento más bajo SMCC desalineados y con la punta de las plaquitas sobre diámetros diversos para operaciones de desbaste con fuertes profundidades de pasada.

I un seggio SSCC ed un seggio più basso SMCC disallineati e con la punta degli inserti su diametri diversi per operazioni di sgrossatura con forti profondità di passata.

fig. 3 KR TS 보링바는 일반적인 chip 제거에 연관된 정삭 및 황삭 작업을 위해 한 개의 bit holder를 조립하여 사용합니다. 단 PT(보호 플레이트) 항상 조립되어야 합니다.

GB the boring bars are fitted with a single bit holder for roughing and finishing operations involving normal chip removal. The serrated surface protection plate PT should always be fitted.

D mit einem Plattenhalter werden die Bohrstangen für Schlicht- und Schrupparbeiten mit normaler Spanabnahme verwendet. PT Schutzplatte für die Kerbzahnfläche immer aufsetzen.

E se utilizan con un solo asiento para operaciones de acabado y desbaste con normal arranque de viruta. Recordar siempre montar la plaquita PT para la protección de la superficie dentada.

I si utilizzano con un solo seggio per operazioni di finitura e sgrossatura con normali asportazioni di truciolo. Ricordarsi sempre di montare la piastrina PT per la protezione della superficie dentellata.

TS 16/16
Ø 18 - 22



TS 20/20
Ø 22 - 28



TS 25/25
Ø 28 - 38



TS 32/32
Ø 35.5 - 50



TS 40/40
Ø 50 - 68



TS 50/50
Ø 68 - 90



TS 50/63
Ø 90 - 120



TS 63/63
Ø 90 - 120



TS 80/80
Ø 120 - 200



D'ANDREA

D'ANDREA MODULHARD'ANDREA

TS 16~40 Ø 18 ~ 68

- DOUBLE-BIT HEADS
- ZWEISCHNEIDERBOHRKÖPFE
- CABEZALES DE DOS CUCHILLAS
- TÊTES À DOUBLE TRANCHANT
- TESTINE BITAGLIANTI

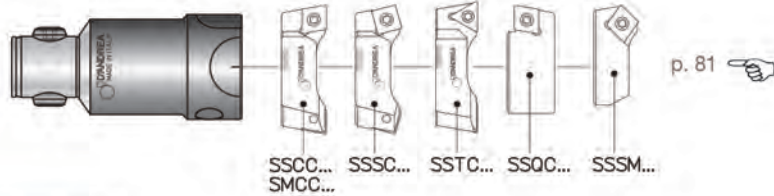

p. 81

REF.	CODE	Kg.
TS 16/16	45 55 016 0034 0	0.05
TS 20/20	45 55 020 0040 0	0.09
TS 25/25	45 55 025 0050 0	0.2
TS 32/32	45 55 032 0063 0	0.35
TS 40/40	45 55 040 0080 0	0.7

REF.	CODE	Kg.
TS 50/50	45 53 050 0100 0	1.5
TS 50/63	45 53 063 0080 0	2
TS 63/63	45 54 063 0125 0	3
TS 80/80	45 54 080 0140 0	5.3

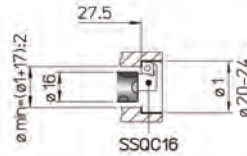
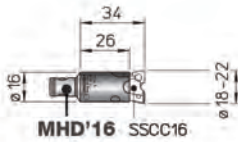

TS 16/16
Ø 18 - 22

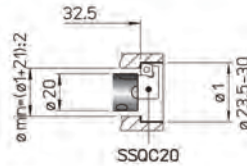
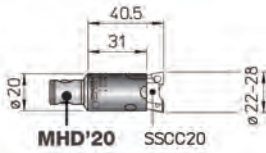

TS 20/20
Ø 22 - 28

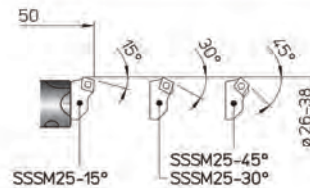
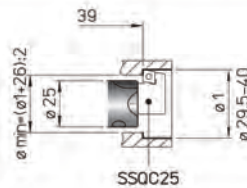
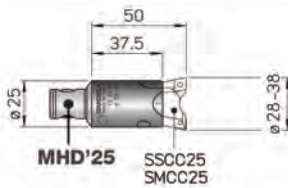

TS 25/25
Ø 28 - 38

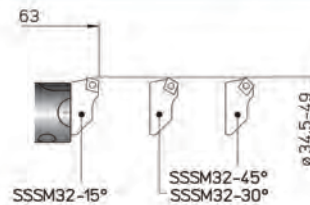
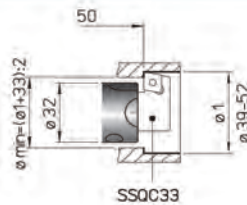
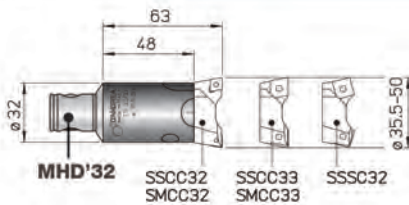

TS 32/32
Ø 35.5 - 50

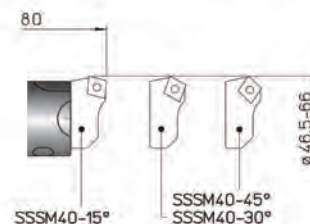
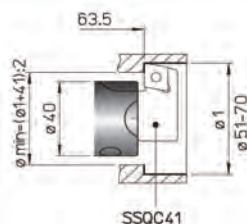
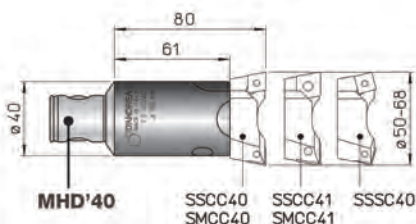

TS 40/40
Ø 50 - 68



TS 50~80 Ø 68 ~ 200

- DOUBLE-BIT HEADS
- ZWEISCHNEIDERBOHRKÖPFE
- CABEZALES DE DOS CUCHILLAS
- TÊTES À DOUBLE TRANCHANT
- TESTINE BITAGLIANTI

TS 50/50 Ø 68 ~ 90

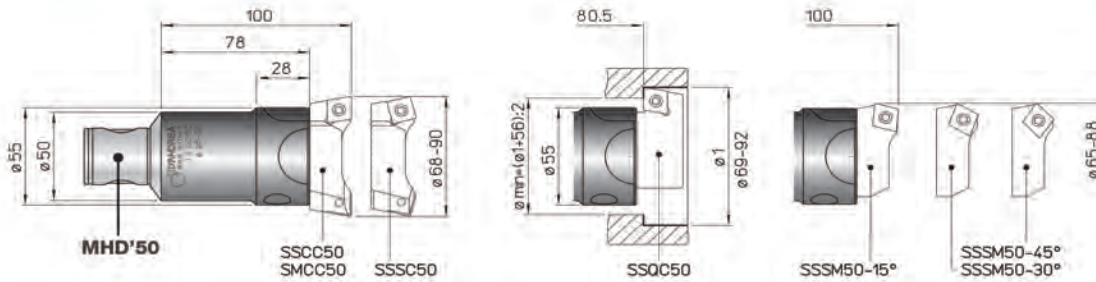

TS 50/63 Ø 90 ~ 120

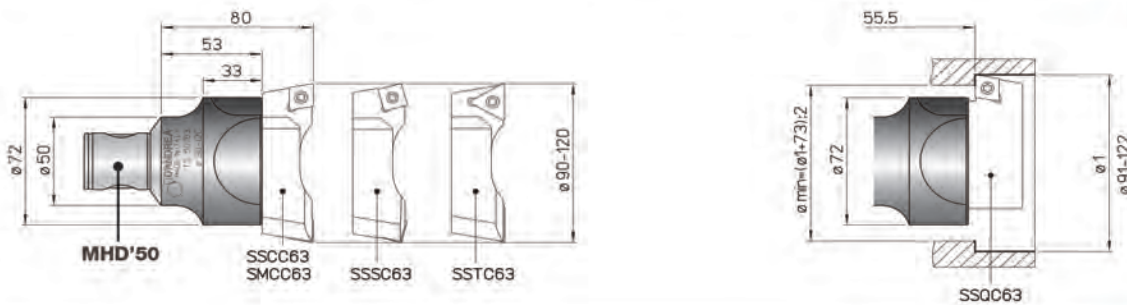

TS 63/63 Ø 90 ~ 120

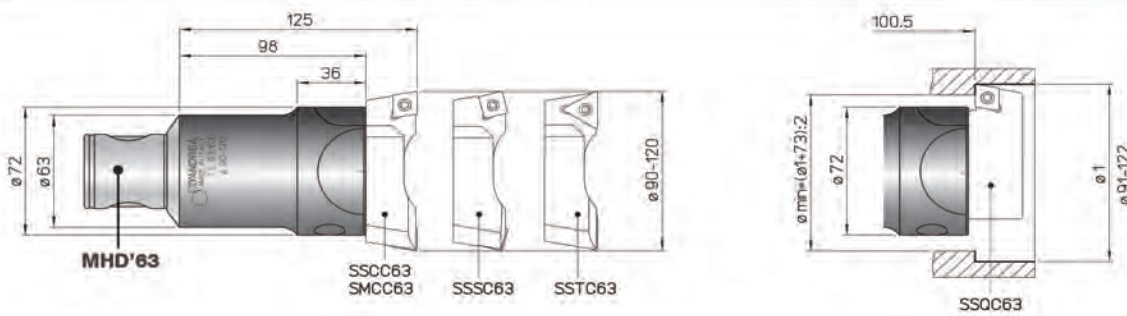

TS 80/80 Ø 120 ~ 160

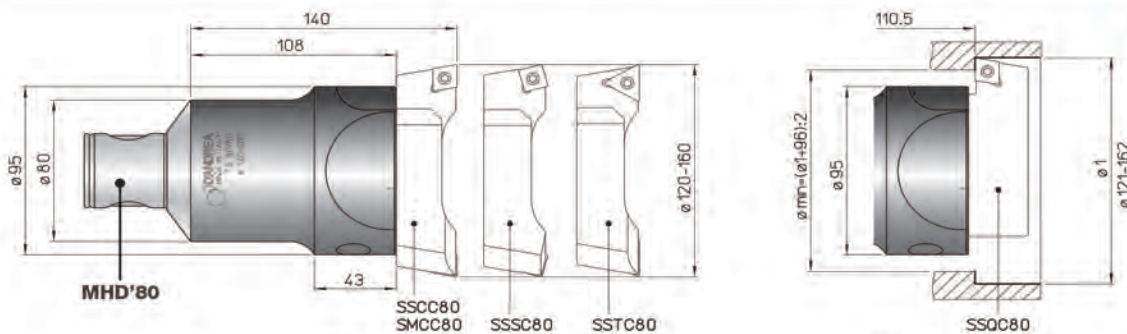

Ø 160 ~ 200

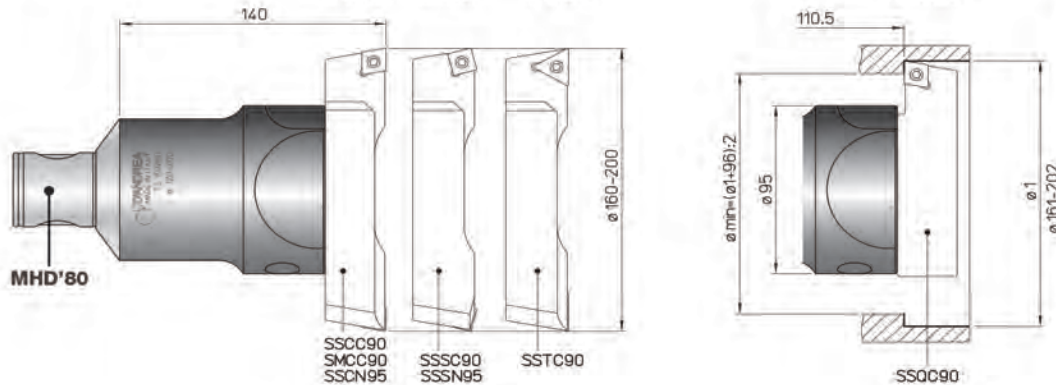

D'ANDREA

D'ANDREA MODULHARD'ANDREA

- BIT-HOLDERS FOR DOUBLE-BIT ITEMS
- PLATTENHALTER FÜR ZWEISCHNEIDERWERKZEUGE
- PORTAPLAQUITAS PARA ASIENTOS A DOS CUCHILLAS
- PORTE-PLAQUETTES POUR PRODUITS À DEUX COUPANTS
- SEGGI PER BITAGLIENTI

SSCC - SMCC - SSSC

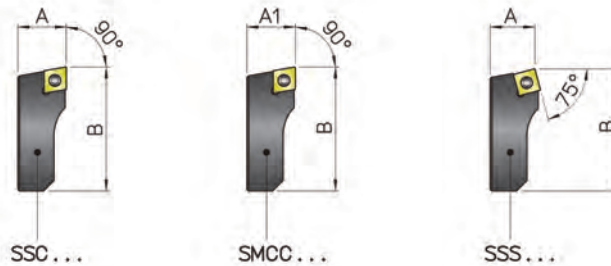

REF.	CODE	A	A1	B					Kg.
SSCC 16	47 050 05 16 201	8		15	CCMT 0602..	-	TS 25	TORX T08	0.003
SSCC 20	47 050 05 20 201	9.5		19					0.006
SSCC 25	47 050 05 25 201	12.5	-	23					0.01
SSCC 32	47 050 05 32 201			32					0.02
SSCC 33	47 050 05 32 204	15		32	CCMT 09T3..	-	TS 4	TORX T15	0.025
SSCC 40	47 050 05 40 201		-	40					0.06
SSCC 41	47 050 05 40 204	19		40	CCMT 1204..	-	TS5	TORX T25	0.06
SSCC 50	47 050 05 50 204	22		54					0.1
SSCC 63	47 050 05 63 201	27		70.5					0.2
SSCC 80	47 050 05 80 201	32		94.5					0.5
SSCC 90	47 050 05 90 201			130					0.7
SSCN 95	47 050 05 95 201	40		130					CNM. 1906..
SMCC 25	47 050 05 25 203		-	12.3	CCMT 0602..	-	TS 25	TORX T08	0.01
SMCC 32	47 050 05 32 203			23					0.02
SMCC 33	47 050 05 32 205		-	14.8	CCMT 09T3..	-	TS 4	TORX T15	0.025
SMCC 40	47 050 05 40 203			32					0.06
SMCC 41	47 050 05 40 205		-	18.7	CCMT 1204..	-	TS 5	TORX T25	0.06
SMCC 50	47 050 05 50 205			40					0.1
SMCC 63	47 050 05 63 203		-	21.7					0.2
SMCC 80	47 050 05 80 203			54					0.5
SMCC 90	47 050 05 90 203			70.5	0.7				
SMCC 95	47 050 05 95 203		-	26.7	130	CNM. 1906..	p. 152		0.9
SMCC 95	47 050 05 95 203			31.7					
SSSC 32	47 050 05 32 202	15		32		SCMT 09T3..	TS 4	TORX T15	0.02
SSSC 40	47 050 05 40 202	19		40					0.06
SSSC 50	47 050 05 50 202	22		54		SCMT 1204..	TS 5	TORX T25	0.1
SSSC 63	47 050 05 63 202	27		70.5	0.2				
SSSC 80	47 050 05 80 202	32		94.5	0.5				
SSSC 90	47 050 05 90 202			130	0.7				
SSSN 95	47 050 05 95 202	40		130	SNM. 1906..	p. 152		0.9	



TS 16~80 Ø 18 ~ 200

- BIT-HOLDERS FOR DOUBLE-BIT ITEMS
- PLATTENHALTER FÜR ZWEISCHNEIDERWERKZEUGE
- PORTAPLAQUITAS PARA ASIENTOS A DOS CUCHILLAS
- PORTE-PLAQUETTES POUR PRODUITS À DEUX COUPANTS
- SEGGI PER BITAGLIANTI

SSTC - SSQC - SSSM

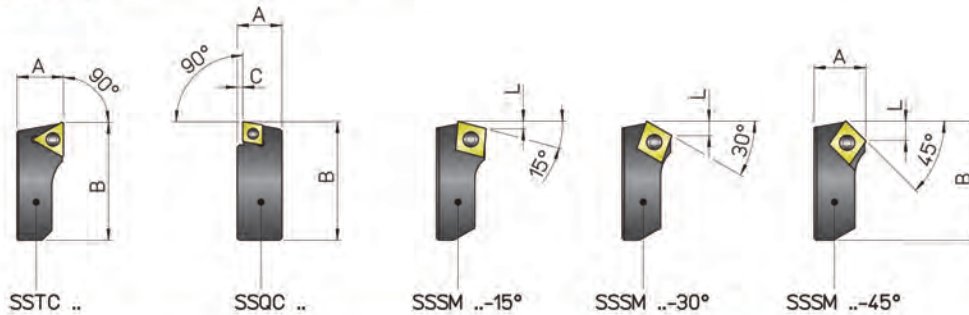

REF.	CODE	A	B	C	L	△	⊖	⌢	⌘	Kg.
SSTC 63	47 050 05 63 206	27	70.5							0.2
SSTC 80	47 050 05 80 206	32	94.5	-	-	TCMT 2204..	-	TS 5	TORX T25	0.5
SSTC 90	47 050 05 90 206		130							0.7
SSQC 16	47 050 05 16 261	10	16	2						0.005
SSQC 20	47 050 05 20 261	11	19.5	1.5	-	-	CCMT 0602..	TS 25	TORX T08	0.008
SSQC 25	47 050 05 25 261	14.5	24	2.5						0.02
SSQC 33	47 050 05 33 261	17	32	3	-	-	CCMT 09T3..	TS 4	TORX T15	0.03
SSQC 41	47 050 05 41 261	21	42							0.08
SSQC 50	47 050 05 50 261	24.5	57							0.15
SSQC 63	47 050 05 63 261	28.5	76	3.5	-	-	CCMT 1204..	TS 5	TORX T25	0.3
SSQC 80	47 050 05 80 261	31.5	101							0.6
SSQC 90	47 050 05 90 261		122							0.8
SSSM 25-15°	47 050 05 25 211	12.5	23	-	1.6					0.01
SSSM 25-30°	47 050 05 25 213			-	3					
SSSM 25-45°	47 050 05 25 215			-	4.3					
SSSM 32-15°	47 050 05 32 211	15	31	-	1.6					0.025
SSSM 32-30°	47 050 05 32 213			-	3					
SSSM 32-45°	47 050 05 32 215			-	4.3					
SSSM 40-15°	47 050 05 40 211	19	39	-	2.4					0.06
SSSM 40-30°	47 050 05 40 213			-	4.6					
SSSM 40-45°	47 050 05 40 215			-	6.5					
SSSM 50-15°	47 050 05 50 211	22	53	-	3.2					0.1
SSSM 50-30°	47 050 05 50 213			-	6.2					
SSSM 50-45°	47 050 05 50 215			-	8.8					

- COVER PLATES
- ABDECKPLATTEN
- PROTECCIONES
- CACHES DE PROTECTION
- PROTEZIONI MILLERIGHE

PT

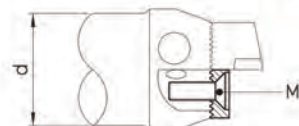
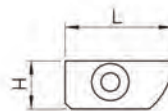

REF.	CODE	d	H	L	M
PT 16	38 47 65 000160	16	7	14	M 3x12
PT 20	38 47 65 000200	20	8.5	17	M 4x14
PT 25	38 47 65 000250	25	10.2	21	M 4x16
PT 32	38 47 65 000320	32	13.9	28	M 5x20
PT 40	38 47 65 000400	40	17.4	35	M 6x25
PT 50	38 47 65 000500	50	21.4	47.5	M 8x25
PT 63	38 47 65 000630	63	26.4	62	M 10x30
PT 80	38 47 65 000800	80	33.9	82.5	M 12x35

D'ANDREA MODULHARD'ANDREA

TRD Ø 28 ~ 120

- DOUBLE-BIT TESTAROSSA
- TESTAROSSA ZWEISCHNEIDERKÖPFE
- TESTAROSSA DE DOS CUCHILLAS
- DOUBLE TRANCHANT TESTAROSSA
- TESTAROSSA BITAGLIENTE

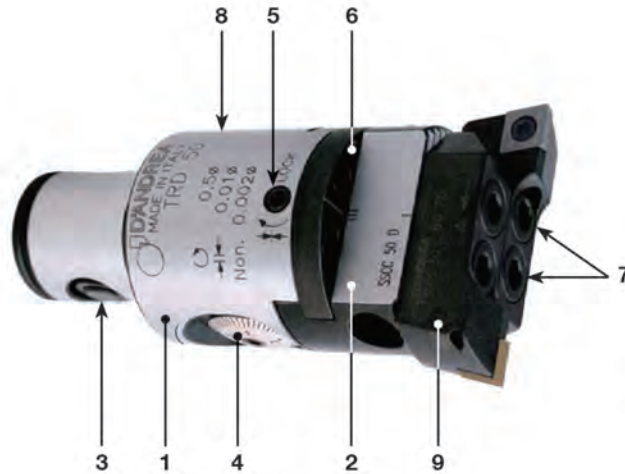

Dom. Brev. Dep.
Patent Pending

- Body
 - Körper
 - Cuerpo
 - Corps
 - Corpo
- Slide toolholder
 - Werkzeugschlitten
 - Guía portaherramientas
 - Coulisseau
 - Slitta portautensili
- Expanding radial pin
 - Spreizbolzen
 - Perno radial expansible
 - Tige radiale expansible
 - Perno radiale espandibile
- Vernier scale
 - Nonius
 - Nonio
 - Vernier
 - Nonio
- Slide clamp screw
 - Schlittenklemmschraube
 - Tornillo bloqueo guía
 - Vis blocage coulisseau
 - Vite bloccaggio slitta
- Coolant outlet
 - Kühlmittelaustritt
 - Agujero salida refrigerante
 - Sortie du liquide d'arrosage
 - Uscita refrigerante

- Tools clamp screws
 - Werkzeugklemmschrauben
 - Tornillos bloqueo herramienta
 - Vis blocage outil
 - Viti bloccaggio utensile
- Oiler
 - Schmiernippel
 - Engrasador
 - Graisseur
 - Oliatore
- Bit holder
 - Plattenhalter
 - Portaplaquita
 - Porte-plaquettes
 - Seggio portainseriti

10 µm
nonio
2 µm
vernier



KR TRD HEAD 는 황삭과 정교한 정삭 작업을 동시에 가공할수 있습니다.

GB The main advantage of the TRD head is that it can be pre-regulated independently of the bit holders found on the slide. This allows both roughing and high precision finish work at the same time.

D Der Hauptvorteil der TRD Köpfe liegt darin, dass die auf dem Schlitten montierten Sitze unabhängig voneinander voreingestellt werden können. Dies ermöglicht gleichzeitige Grob- und Feinbearbeitungen.

E El punto fuerte de los TRD es el pre-ajuste independiente de los asientos montados sobre la corredera que permiten realizar a la vez operaciones de desbaste y acabado.

I Il punto di forza delle TRD è la pre-regolazione indipendente dei seggi montati sulla slitta che consentono di eseguire contemporaneamente lavorazioni di sgrossatura e di finitura.



KR 더블 BIT TRD HEAD 는 5마이크론의 Radial 조절이 가능한 슬라이드 메커니즘으로 정교함과 견고함을 동시에 만족시켜 황삭과 정교한 정삭 작업을 동시에 가공이 가능하며 할 수 있다. 또한 눈금을 쉽게 읽을 수 있고 장비에서 즉시 효과를 확인할 수 있다.

GB FEATURES. The double-bit TRD heads allow both roughing and high precision finish thanks to their rigidity and the sensitivity of the sliding mechanism which can achieve radial correction of 5 microm. This can be effected directly on the machine and easily read on the vernier scale.

D MERKMALE. Die TRD Zweischneiderköpfe ermöglichen eine kombinierte und hochpräzise Vor- und Fertigbearbeitung. Dank der Steifigkeit und der auf radial 5 µm über Skala genauen Schlittenverstellung kann das Mass direkt an der Maschine korrigiert werden.

E CARACTERÍSTICAS. Los cabezales de dos cuchillas TRD permiten realizar operaciones combinadas de desbaste y acabado de alta precisión, gracias a su rigidez y a la sensibilidad del mecanismo de deslizamiento con ajuste de 5 micras en radio, que puede leerse en el nonio y realizarse directamente en la máquina.

I CARATTERISTICHE. Le testine bitaglienti TRD consentono lavorazioni combinate di sgrossatura e finitura di alta precisione, grazie alla loro rigidezza e alla sensibilità dello spostamento slitta con regolazione di 5 micron sul raggio, leggibile sul nonio ed eseguibile anche in macchina.

TRD 25
Ø 28 ~ 36



TRD 32
Ø 36 ~ 46



TRD 40
Ø 46 ~ 60



TRD 50
Ø 60 ~ 75



TRD 63
Ø 75 ~ 95



TRD 80
Ø 95 ~ 120



D'ANDREA

D'ANDREA MODULHARD'ANDREA

TRD 25~80 Ø 28 ~ 120

- DOUBLE-BIT TESTAROSSA
- TESTAROSSA ZWEISCHNEIDERKÖPFE
- TESTAROSSA DE DOS CUCHILLAS
- DOUBLE TRANCHANT TESTAROSSA
- TESTAROSSA BITAGLIANTE

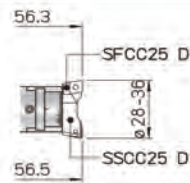
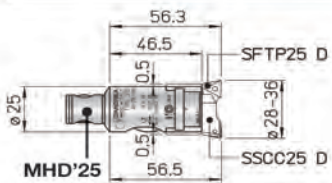
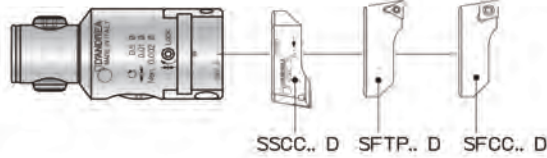

TRD 25
Ø 28 ~ 36

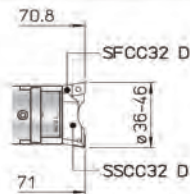
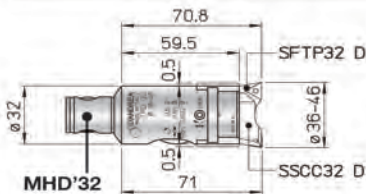

TRD 32
Ø 36 ~ 46

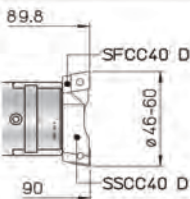
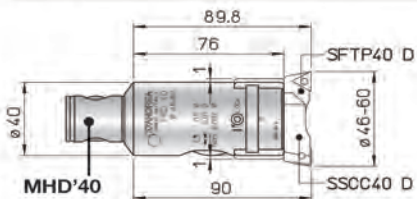

TRD 40
Ø 46 ~ 60

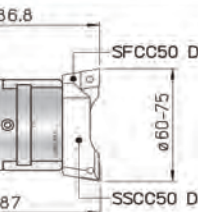
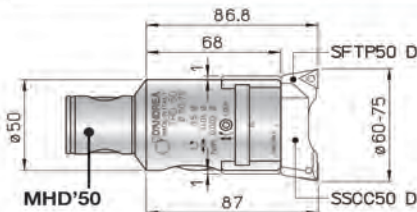

TRD 50
Ø 60 ~ 75

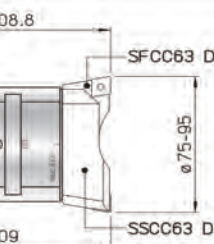
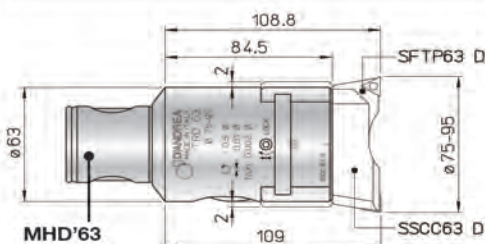

TRD 63
Ø 75 ~ 95

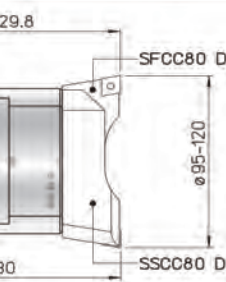
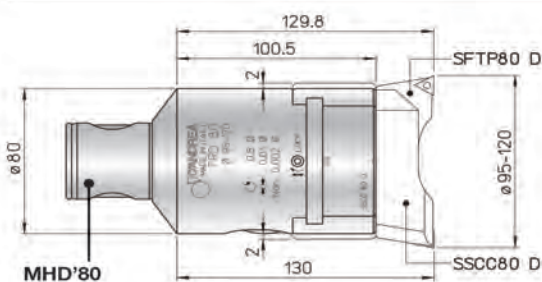

TRD 80
Ø 95 ~ 120



- DOUBLE-BIT TESTAROSSA
- TESTAROSSA ZWEISCHNEIDERKÖPFE
- TESTAROSSA DE DOS CUCHILLAS
- DOUBLE TRANCHANT TESTAROSSA
- TESTAROSSA BITAGLIENTE

TRD



10 μm
nonio
vernier **2 μm**

REF.	CODE	Kg.
TRD 25	45 50 225 0057 1	0.2
TRD 32	45 50 232 0071 1	0.35
TRD 40	45 50 240 0090 1	0.7
TRD 50	45 50 250 0086 1	1.5
TRD 63	45 50 263 0108 1	2.7
TRD 80	45 50 280 0129 1	4.8

- BIT-HOLDERS FOR DOUBLE-BIT TESTAROSSA
- PLATTENHALTER FÜR TESTAROSSA ZWEISCHNEIDERBOHRKÖPFE
- ASIENTOS PARA TESTAROSSA DE DOS CUCHILLAS
- DOUBLE TRANCHANT TESTAROSSA
- SEGGI PER TESTAROSSA BITAGLIENTE

SS-SF

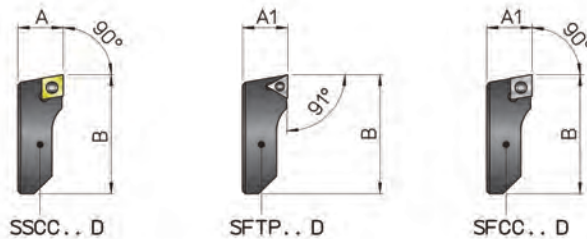

REF.	CODE	A	A1	B					Kg.
SSCC 25 D	47 050 05 25 220	10	-	24	-	CCMT 0602..	TS 25	TORX T08	0.008
SSCC 32 D	47 050 05 32 220	11.5	-	30	-				0.015
SSCC 40 D	47 050 05 40 220	14	-	40	-				0.03
SSCC 50 D	47 050 05 50 220	19	-	54	-	CCMT 09T3..	TS 4	TORX T15	0.06
SSCC 63 D	47 050 05 63 220	24.5	-	68	-				0.15
SSCC 80 D	47 050 05 80 220	29.5	-	87	-				0.3
SFTP 25 D	47 050 05 25 030	-	9.8	24	TPGX 0902..	-	CS 250T	TORX T08	0.008
SFTP 32 D	47 050 05 32 030	-	11.3	30					0.015
SFTP 40 D	47 050 05 40 030	-	13.8	40					0.03
SFTP 50 D	47 050 05 50 030	-	18.8	54	TPGX 1103..	-	CS 300890T		0.06
SFTP 63 D	47 050 05 63 030	-	24.3	68					0.15
SFTP 80 D	47 050 05 80 030	-	29.3	87					0.3
SFCC 25 D	47 050 05 25 020	-	9.8	24	-	CCGT 0602..	TS 25	TORX T08	0.008
SFCC 32 D	47 050 05 32 020	-	11.3	30	-				0.015
SFCC 40 D	47 050 05 40 020	-	13.8	40	-				0.03
SFCC 50 D	47 050 05 50 020	-	18.8	54	-	CCGT 09T3..	TS 4	TORX T15	0.06
SFCC 63 D	47 050 05 63 020	-	24.3	68	-				0.15
SFCC 80 D	47 050 05 80 020	-	29.3	87	-				0.3

- 1 • Body
• Körper
• Cuerpo
• Corps
• Corpo
- 2 • Slide toolholder
• Werkzeugschlitten
• Guía portaherramientas
• Coulisseau
• Slitta portautensili
- 3 • Expanding radial pin
• Spreizbolzen
• Perno radial expansible
• Tige radiale expansible
• Perno radiale espandibile
- 4 • Vernier scale
• Nonius
• Nonio
• Vernier
• Nonio
- 5 • Slide clamp screw
• Schlittenklemmschraube
• Tornillo bloqueo guía
• Vis blocage coulisseau
• Vite bloccaggio slitta
- 6 • Coolant outlet
• Kühlmittelaustritt
• Agujero salida refrigerante
• Sortie du liquide d'arrosage
• Uscita refrigerante

- 7 • Tools clamp screws
• Werkzeugklemmschrauben
• Tornillo bloqueo herramienta
• Vis blocage outil
• Viti bloccaggio utensile
- 8 • Oiler
• Schmiernippel
• Engrasador
• Graisseur
• Oliatore
- 9 • Bit holder
• Plattenhalter
• Portaplaquita
• Porte-plaquettes
• Seggio portainseriti



10 µm
nonio
vernier **2 µm**



KR IT6 공차의 매우 정교한 작업 또는 우수한 표면 조도가 요한 작업은 TRC HEAD 사용이 해결할 수 있다. TRC HEAD 는 매우 정교하며 5 마이크로미터의 Radial 조정은 눈금으로 쉽게 읽을 수 있고 장비에서 즉시 효과를 확인 할 수 있습니다.

GB FEATURES. High precision work to IT6 tolerance, with excellent surface finish, is achieved using TRC boring heads. These are very sensitive and radial correction of 5 micron can be effected directly on the machine and easily read on the vernier scale.

D MERKMALE. Die TRC Köpfe ermöglichen Bearbeitungen mit hoher Präzision und Toleranzen mit Grad IT6 bei hochwertiger Oberflächengüte. Sie besitzen eine Feinverstellung mit einer Genauigkeit von radial 5 µm, wobei das Maß auf der Skala abgelesen und auch direkt an der Maschine eingestellt werden kann.

E CARACTERÍSTICAS. Los cabezales TRC permiten realizar operaciones de alta precisión con tolerancias de grado IT6 con un extraordinario acabado de la superficie. Tienen una sensibilidad de ajuste de 5 micras en radio, de fácil lectura en el nonio y corregibles directamente sobre la máquina.

I CARATTERISTICHE. Le testine TRC consentono lavorazioni di alta precisione con tolleranze di grado IT6 con ottima finitura superficiale. Hanno una sensibilità di regolazione di 5 micron sul raggio, facilmente leggibile sul nonio ed eseguibile anche in macchina.



TRC Ø 2.5 ~ 200

testarossadandrea

TRC 14
Ø 14.5 ~ 18



TRC 16
Ø 18 ~ 24



TRC 20
Ø 22 ~ 30



TRC 25
Ø 28 ~ 40



TRC 32
Ø 35 ~ 53



TRC 40
Ø 48 ~ 66



TRC 50
Ø 2.5 ~ 110



TRC 63
Ø 6 ~ 125



TRC 80
Ø 6 ~ 200



D'ANDREA

D'ANDREA MODULHARD'ANDREA

TRC 14~40 Ø 14.5 ~ 66

• TESTAROSSA

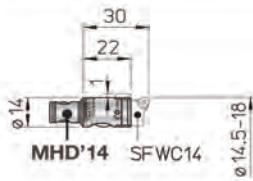
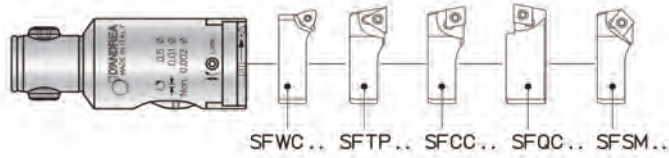

TRC 14
Ø 14.5 - 18

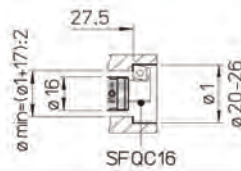
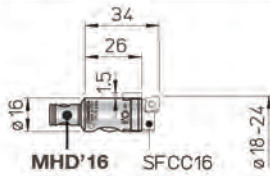

TRC 16
Ø 18 - 24

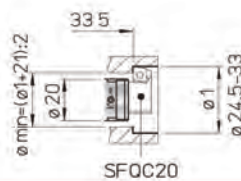
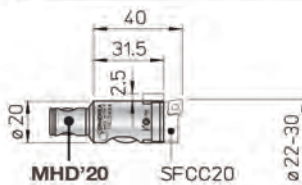

TRC 20
Ø 22 - 30

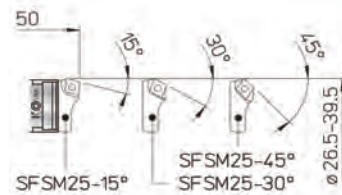
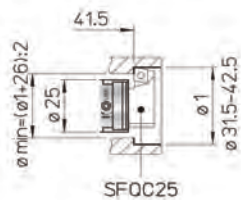
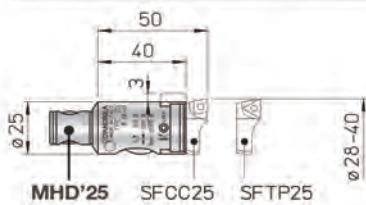

TRC 25
Ø 28 - 40

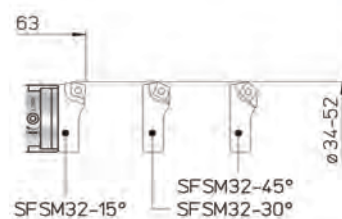
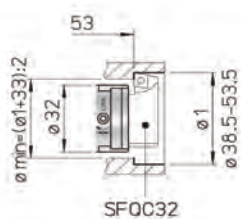
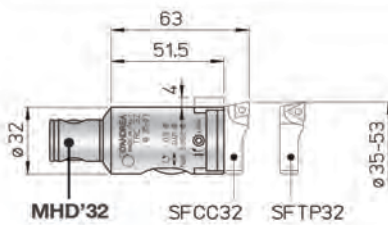

TRC 32
Ø 35 - 53

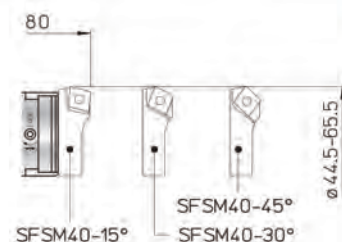
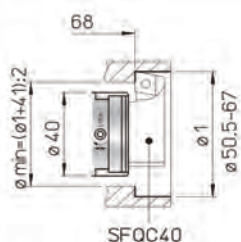
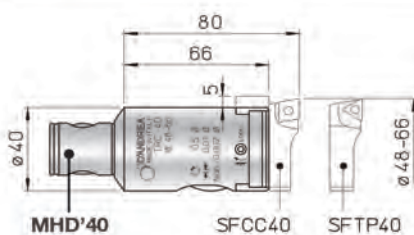

TRC 40
Ø 48 - 66

D'ANDREA



• TESTAROSSA

TRC



10 μm
nonio
vernier **2 μm**

REF.	CODE	Kg.
TRC 14	45 50 114 0030 1	0.02
TRC 16	45 50 116 0034 1	0.05
TRC 20	45 50 120 0040 1	0.1
TRC 25	45 50 125 0050 1	0.2
TRC 32	45 50 132 0063 1	0.35
TRC 40	45 50 140 0080 1	0.7

- BIT-HOLDERS FOR TESTAROSSA
- PLATTENHALTER FÜR TESTAROSSA
- PORTA-PLAQUITAS PARA TESTAROSSA
- PORTE-PLAQUETTES POUR TESTAROSSA
- SEGGI PER TESTAROSSA

SF

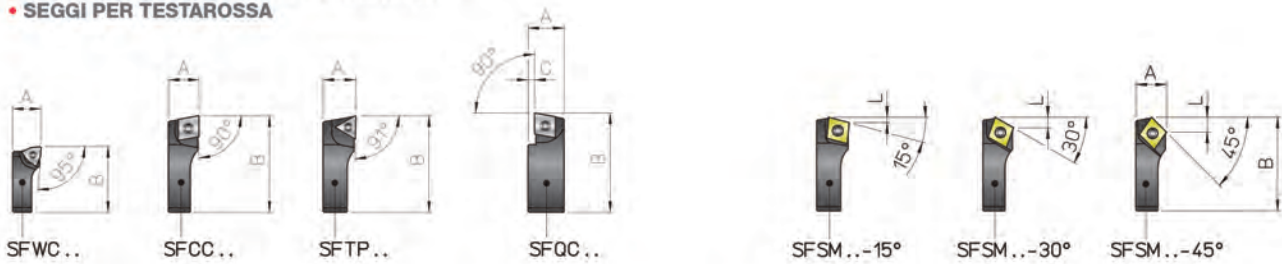

REF.	CODE	A	B	C	L						Kg.
SFWC 14	47 050 05 14 002	8	14	-	-	WCGT 0201..	-	-	TS 211	TORX T06	0.003
SFCC 16	47 050 05 16 002	8	17	-	-	-	-	-	-	-	0.003
SFCC 20	47 050 05 20 002	8.5	21	-	-	-	CCGT 0602..	-	TS 25	TORX T08	0.005
SFCC 25	47 050 05 25 002	10	26.5	-	-	-	-	-	-	-	0.01
SFCC 32	47 050 05 32 002	11.5	34.5	-	-	-	-	-	-	-	0.02
SFCC 40	47 050 05 40 002	14	44	-	-	-	CCGT 09T3..	-	TS 4	TORX T15	0.04
SFTP 25	47 050 05 25 001	10	26.5	-	-	-	-	TPGX 0902..	CS 250T	-	0.01
SFTP 32	47 050 05 32 001	11.5	34.5	-	-	-	-	-	-	TORX T08	0.02
SFTP 40	47 050 05 40 001	14	44	-	-	-	-	TPGX 1103..	CS 300890T	-	0.04
SFQC 16	47 050 05 16 062	10	18	2	-	-	-	-	-	-	0.005
SFQC 20	47 050 05 20 062	10.5	22.5	-	-	-	CCMT 0602..	-	TS 25	TORX T08	0.008
SFQC 25	47 050 05 25 062	12	28.5	2.5	-	-	-	-	-	-	0.01
SFQC 32	47 050 05 32 062	13.5	35.5	-	-	-	-	-	-	-	0.03
SFQC 40	47 050 05 40 062	16.5	46	3	-	-	CCMT 09T3..	-	TS 4	TORXT15	0.06
SFSM 25-15°	47 050 05 25 011	10	25.5	-	1.6	-	-	-	-	-	-
SFSM 25-30°	47 050 05 25 013	-	-	-	3	-	-	-	-	-	0.01
SFSM 25-45°	47 050 05 25 015	-	-	-	4.3	-	-	-	-	-	-
SFSM 32-15°	47 050 05 32 011	11.5	33.5	-	1.6	-	CCMT 0602..	-	TS 25	TORX T08	-
SFSM 32-30°	47 050 05 32 013	-	-	-	3	-	-	-	-	-	0.02
SFSM 32-45°	47 050 05 32 015	-	-	-	4.3	-	-	-	-	-	-
SFSM 40-15°	47 050 05 40 011	14	42.5	-	2.4	-	-	-	-	-	-
SFSM 40-30°	47 050 05 40 013	-	-	-	4.6	-	CCMT 09T3..	-	TS 4	TORXT15	0.03
SFSM 40-45°	47 050 05 40 015	-	-	-	6.5	-	-	-	-	-	-

D'ANDREA

D'ANDREA MODULHARD'ANDREA

TRC 50 Ø 2.5 - 110

• TESTAROSSA



10 µm

nonio
vernier **2 µm**

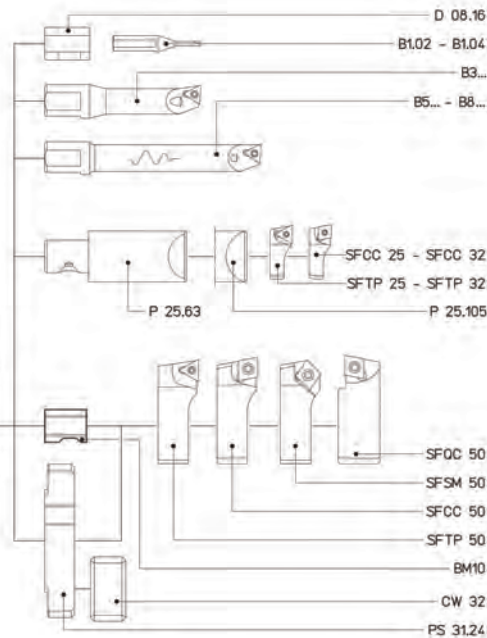
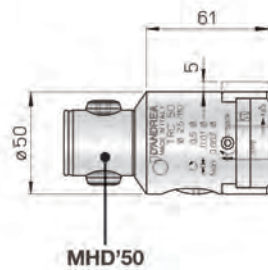

Ø 2.5 - 30

Ø 28 - 56

Ø 54 - 110

REF.	CODE	Kg.
TRC 50	45 50 150 0080 1	1

KIT K01
Ø 6 - 110

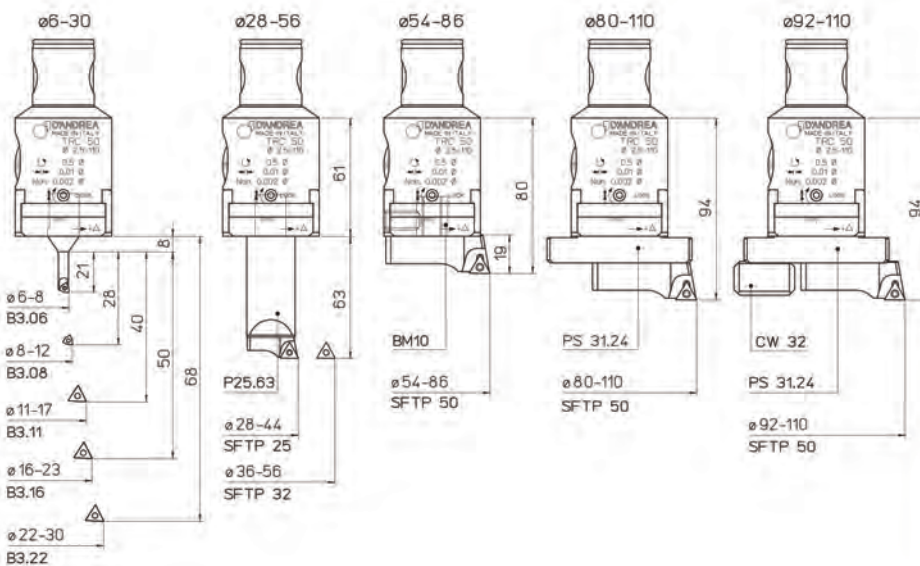

K01 TRC 50		
1 TRC 50	1 B3.06	1 SFTP25
1 P25.63	1 B3.08	1 SFTP32
1 BM10	1 B3.11	1 SFTP50
1 PS 31.24	1 B3.16	
1 CW 32	1 B3.22	
5 TPGX 090202L DC100		
1 TPGX 110302L DC100		
2 WCGT 020102L DC100		

REF.	CODE	Ø
K01 TRC 50	65 50 150 1050 2	6 - 110

D'ANDREA



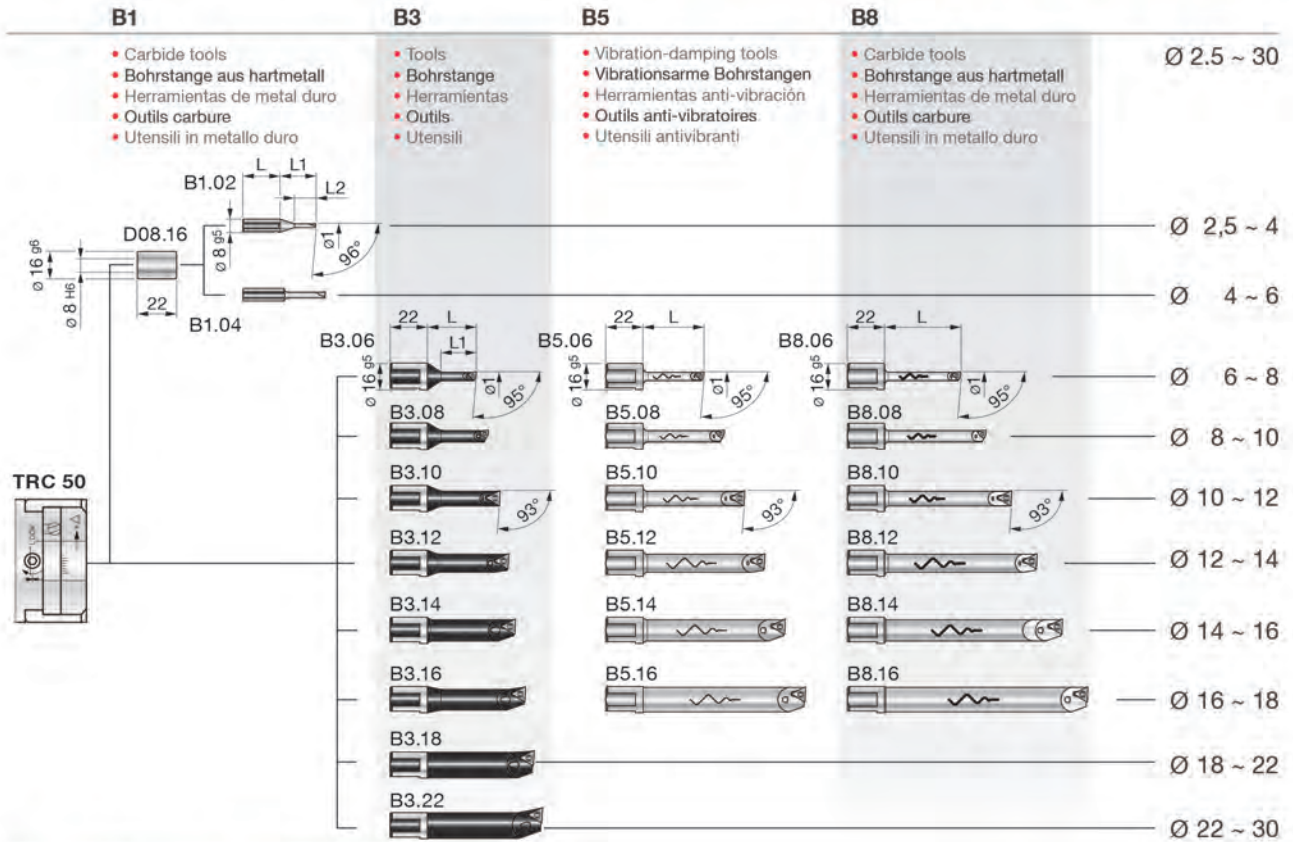

B1

- Carbide tools
- Bohrstange aus hartmetall
- Herramientas de metal duro
- Outils carbure
- Utensili in metallo duro

B3

- Tools
- Bohrstange
- Herramientas
- Outils
- Utensili

B5

- Vibration-damping tools
- Vibrationsarme Bohrstangen
- Herramientas anti-vibración
- Outils anti-vibratoires
- Utensili antivibranti

B8

- Carbide tools
- Bohrstange aus hartmetall
- Herramientas de metal duro
- Outils carbure
- Utensili in metallo duro

Ø 2.5 ~ 30

Ø 2,5 ~ 4

Ø 4 ~ 6

Ø 6 ~ 8

Ø 8 ~ 10

Ø 10 ~ 12

Ø 12 ~ 14

Ø 14 ~ 16

Ø 16 ~ 18

Ø 18 ~ 22

Ø 22 ~ 30

REF.	CODE	Kg.
D08.16	20 056 01 16 08 2	0.02

REF.	CODE	Ø1	L	L1	L2	Kg.
B1.02	57 201 05 02 001	2.5 ~ 4	22	21	12.5	0.02
B1.04	57 201 05 04 001	4 ~ 6	24	24	-	-

REF.	CODE	Ø1	L	L1	⊖	⚠	⌚	🔑	Kg.
B3.06	57 201 05 06 001	6 ~ 8	29	21	WCGT 0201..	-	TS 21	TORX T06	0.035
B3.08	57 201 05 08 001	8 ~ 10	36	28			TS 211		0.04
B3.10	57 201 05 10 001	10 ~ 12	43	35					0.05
B3.11	57 201 05 11 001	11 ~ 13	48	40					0.055
B3.12	57 201 05 12 001	12 ~ 14	48	42					0.06
B3.14	57 201 05 14 001	14 ~ 16	52	50	-	TPGX 0902..	CS 250 T	TORX T08	0.07
B3.16	57 201 05 16 001	16 ~ 18	58						
B3.18	57 201 05 18 001	18 ~ 22	63						0.1
B3.22	57 201 05 22 001	22 ~ 30	68						

B5.06	57 201 05 06 105	6 ~ 8	36		WCGT 0201..	-	TS 21	TORX T06	0.075
B5.08	57 201 05 08 105	8 ~ 10	48				TS 211		0.09
B5.10	57 201 05 10 105	10 ~ 12	60						0.1
B5.12	57 201 05 12 105	12 ~ 14	72		-	TPGX 0902..	CS 250 T	TORX T08	0.2
B5.14	57 201 05 14 105	14 ~ 16	84						0.3
B5.16	57 201 05 16 105	16 ~ 18	96						

B8.06	57 201 05 06 108	6 ~ 8	45		WCGT 0201..	-	TS 21	TORX T06	0.065
B8.08	57 201 05 08 108	8 ~ 10	60				TS 211		0.08
B8.10	57 201 05 10 108	10 ~ 12	75						0.1
B8.12	57 201 05 12 108	12 ~ 14	90		-	TPGX 0902..	CS 250 T	TORX T08	0.2
B8.14	57 201 05 14 108	14 ~ 16	105						0.3
B8.16	57 201 05 16 108	16 ~ 18	120						

D'ANDREA

D'ANDREA MODULHARD'ANDREA

TRC 50 Ø 52 ~ 113.5

- TOOLHOLDERS FOR TESTAROSSA
- WERKZEUGE FÜR TESTAROSSA
- PORTAHERRAMIENTAS PARA TESTAROSSA
- PORTE-OUTILS POUR TESTAROSSA
- PORTAUTENSILI PER TESTAROSSA

PS 31
CW 32
Ø 54 - 110

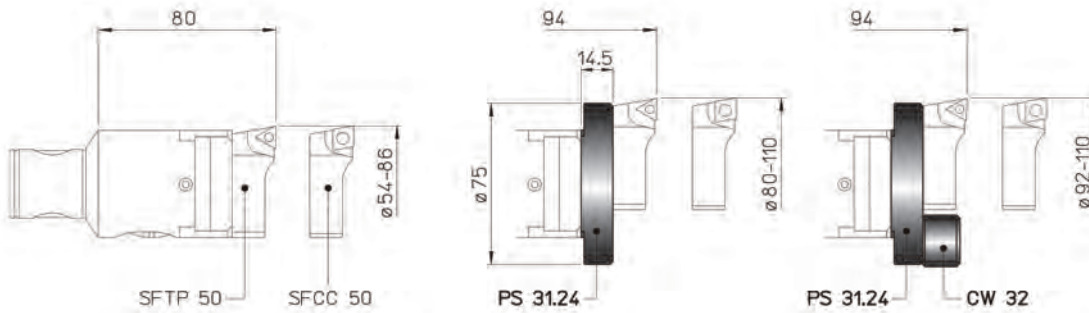

PS 31
Ø 56 - 113.5

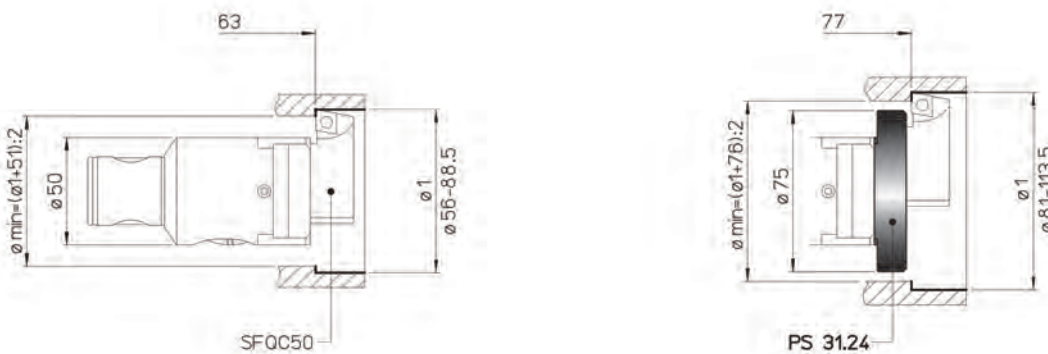

PS 31
Ø 52 - 111

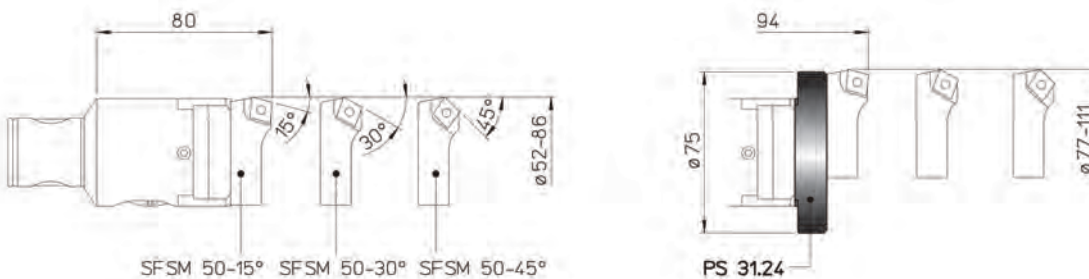

REF.	CODE	Kg.
PS 31.24	43 30 24 14 075 1	0.2
CW 32	39 20 110 032 01	0.5



- TOOLHOLDERS FOR TESTAROSSA
- WERKZEUGE FÜR TESTAROSSA
- PORTAHERRAMIENTAS PARA TESTAROSSA
- PORTE-OUTILS POUR TESTAROSSA
- PORTAUTENSILI PER TESTAROSSA

PS 25
Ø 28 ~ 56

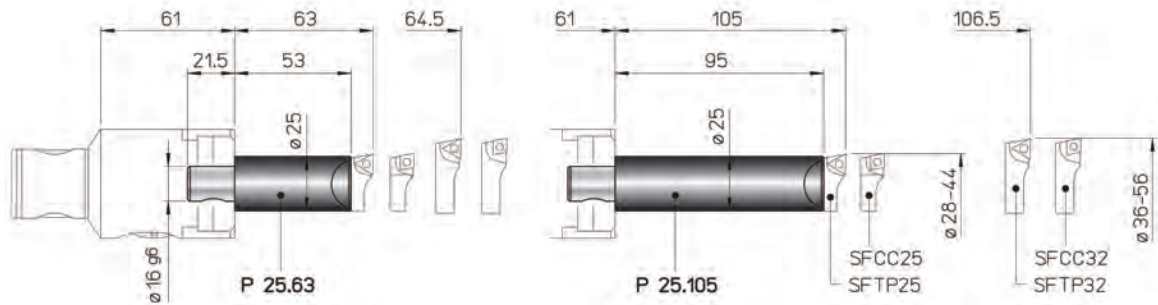

REF.	CODE	Kg.
P25.63	43 51 16 25 063 0	0.5
P25.105	43 51 16 25 105 0	0.8

- BIT-HOLDERS FOR TESTAROSSA
- PLATTENHALTER FÜR TESTAROSSA
- PORTA-PLAQUITAS PARA TESTAROSSA
- PORTE-PLAQUETTES POUR TESTAROSSA
- SEGGI PER TESTAROSSA

SF

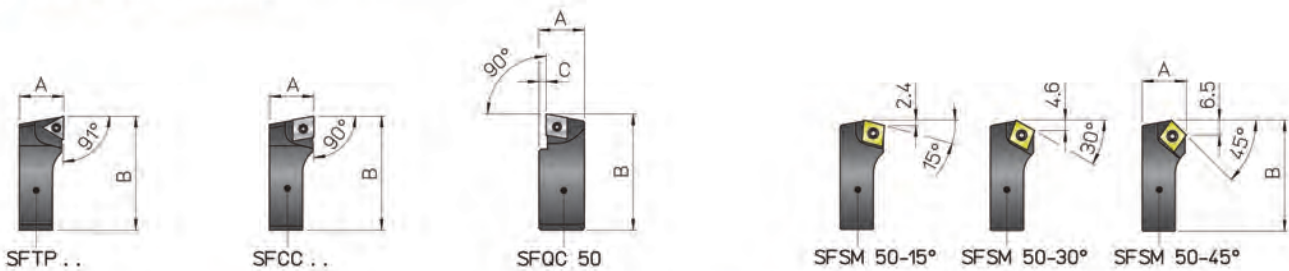

REF.	CODE	A	B	C	△	□	⌋	⌋	Kg.
SFTP 25	47 050 05 25 001	10	26.5	-	TPGX 0902..	-	CS 250T	TORX T08	0.01
SFTP 32	47 050 05 32 001	11.5	34.5	-	-	-	CS 300890T		0.02
SFTP 50	47 050 05 50 001	19	52	-	TPGX 1103..	-	-		0.08
SFCC 25	47 050 05 25 002	10	26.5	-	-	CCGT 0602..	TS 25	TORX T08	0.01
SFCC 32	47 050 05 32 002	11.5	34.5	-	-	-	-	TORX T08	0.02
SFCC 50	47 050 05 50 002	19	52	-	-	CCGT 09T3..	TS 4	TORX T15	0.08
SFQC 50	47 050 05 50 062	20.5	53	3	-	CCMT 09T3..	TS 4	TORXT15	0.1
SFSM 50-15°	47 050 05 50 011	19	50.5	-	-	CCMT 09T3..	TS 4	TORXT15	0.07
SFSM 50-30°	47 050 05 50 013								
SFSM 50-45°	47 050 05 50 015								

D'ANDREA

D'ANDREA MODULHARD'ANDREA

TRC 63 Ø 6 ~ 125

• TESTAROSSA



10 µm
nonio
vernier **2 µm**

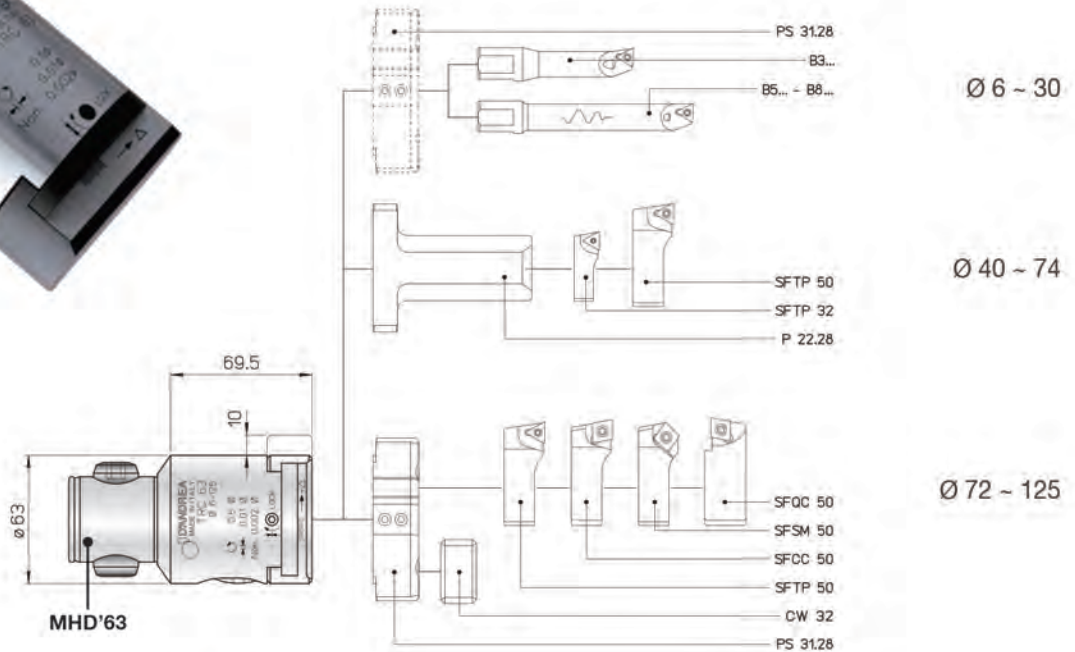

REF.	CODE	Kg.
TRC 63	45 50 163 0100 1	2

KIT K01
Ø 6 ~ 125

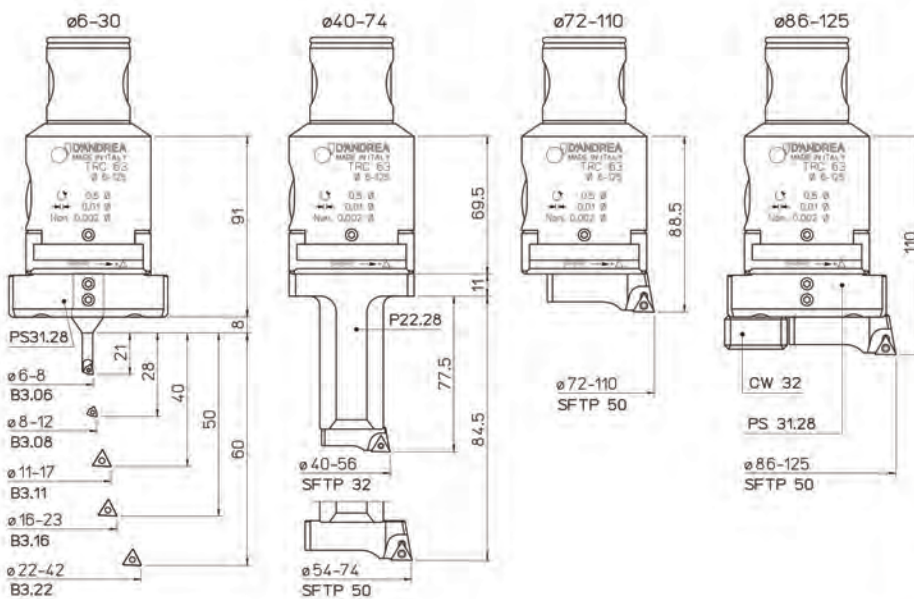

K01 TRC 63		
1 TRC 63		
1 PS31.28	1 B3.06	
1 CW 32	1 B3.08	
1 P22.28	1 B3.11	
1 SFTP32	1 B3.16	
1 SFTP50	1 B3.22	
5 TPGX 090202L DC100		
1 TPGX 110302L DC100		
2 WCGT 020102L DC100		

REF.	CODE	Ø
K01 TRC 63	65 50 163 1063 2	6 ~ 125

D'ANDREA



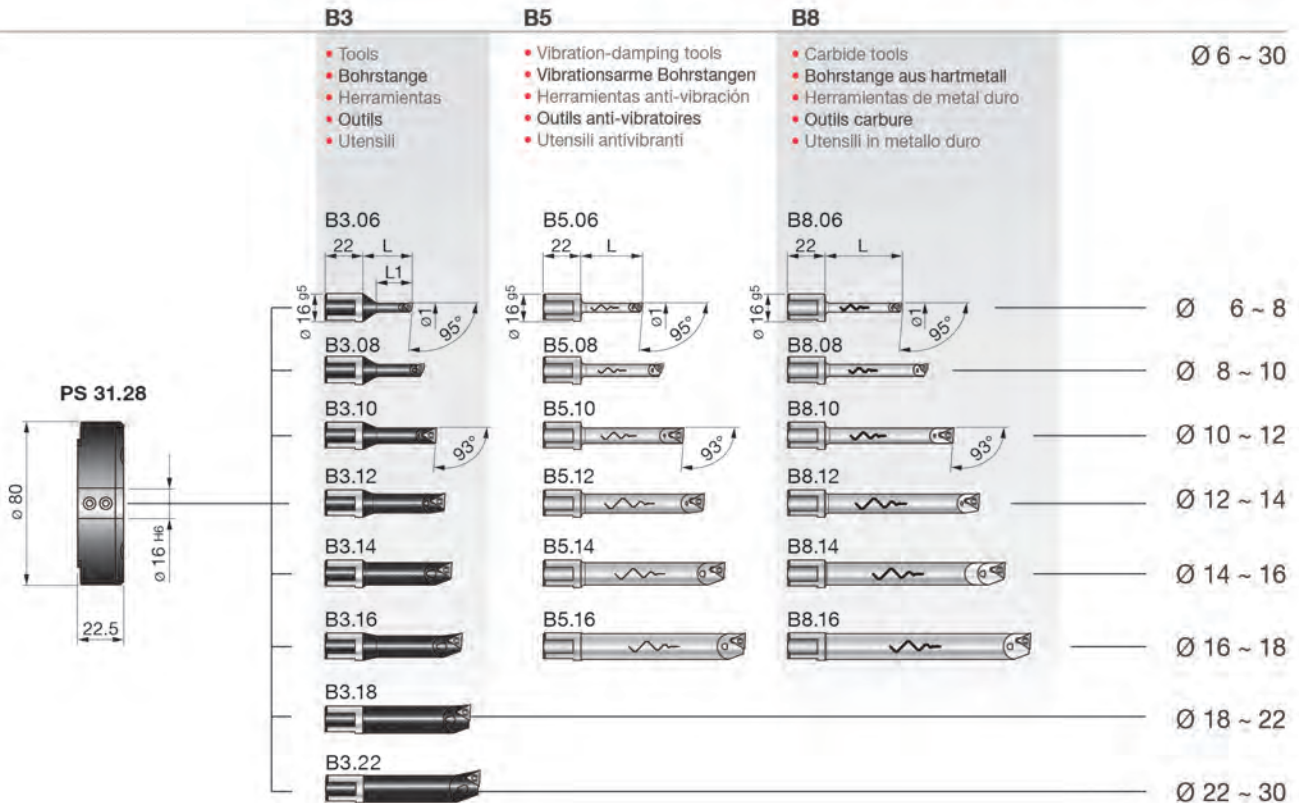

REF.	CODE	Kg.
PS 31.28	43 30 28 22 080 1	0.3

REF.	CODE	Ø1	L	L1	⚠	⚠	🔩	🔩	Kg.
B3.06	57 201 05 06 001	6 - 8	29	21	WCGT 0201..	-	TS 21	TORX T06	0.035
B3.08	57 201 05 08 001	8 - 10	36	28			TS 211		0.04
B3.10	57 201 05 10 001	10 - 12	43	35	-	TPGX 0902..	CS 250 T	TORX T08	0.05
B3.11	57 201 05 11 001	11 - 13	48	40					0.055
B3.12	57 201 05 12 001	12 - 14	48	42					0.06
B3.14	57 201 05 14 001	14 - 16	52	50					0.07
B3.16	57 201 05 16 001	16 - 18	58	-	-	TPGX 0902..	CS 250 T	TORX T08	0.1
B3.18	57 201 05 18 001	18 - 22	63	-					0.1
B3.22	57 201 05 22 001	22 - 30	68	-					0.1
B5.06	57 201 05 06 105	6 - 8	36	-	WCGT 0201..	-	TS 21	TORX T06	0.075
B5.08	57 201 05 08 105	8 - 10	48				28		TS 211
B5.10	57 201 05 10 105	10 - 12	60	-	-	TPGX 0902..	CS 250 T	TORX T08	0.1
B5.12	57 201 05 12 105	12 - 14	72	0.2					
B5.14	57 201 05 14 105	14 - 16	84	0.2					
B5.16	57 201 05 16 105	16 - 18	96	0.3					
B8.06	57 201 05 06 108	6 - 8	45	-	WCGT 0201..	-	TS 21	TORX T06	0.065
B8.08	57 201 05 08 108	8 - 10	60				28		TS 211
B8.10	57 201 05 10 108	10 - 12	75	-	-	TPGX 0902..	CS 250 T	TORX T08	0.1
B8.12	57 201 05 12 108	12 - 14	90	0.2					
B8.14	57 201 05 14 108	14 - 16	105	0.2					
B8.16	57 201 05 16 108	16 - 18	120	0.3					

D'ANDREA

D'ANDREA MODULHARD'ANDREA

TRC 63 Ø 69 ~ 129.5

- TOOLHOLDERS FOR TESTAROSSA
- WERKZEUGE FÜR TESTAROSSA
- PORTAHERRAMIENTAS PARA TESTAROSSA
- PORTE-OUTILS POUR TESTAROSSA
- PORTAUTENSILI PER TESTAROSSA

PS 31
CW 32
Ø 72-125

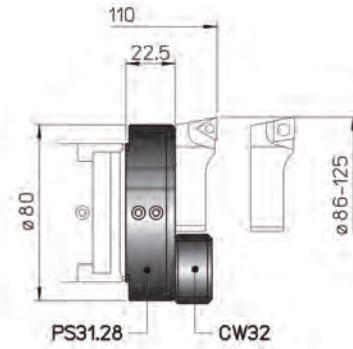
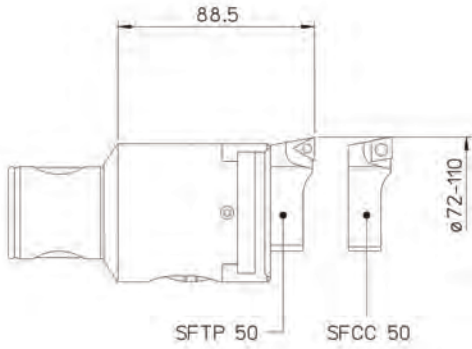

PS 31
Ø 72.5 - 129.5

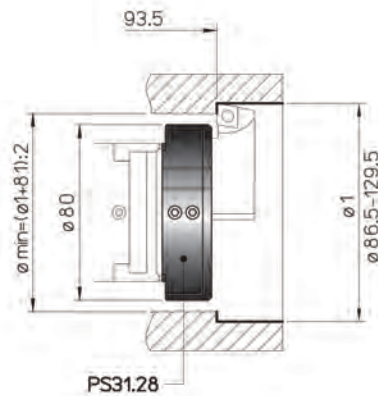
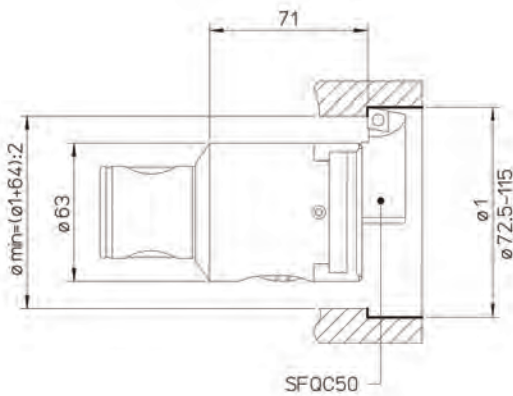

PS 31
Ø 69 - 127

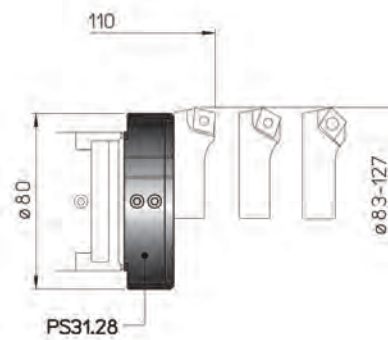
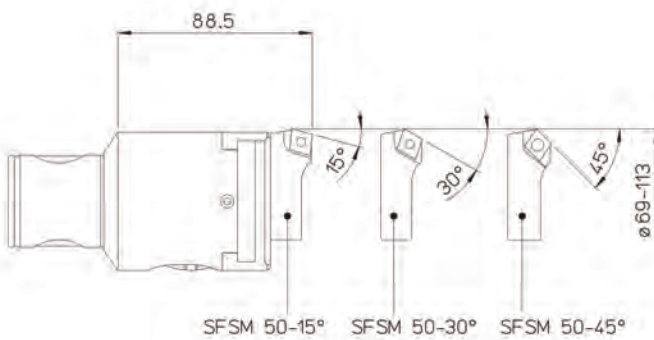

REF.	CODE	Kg.
PS 31.28	43 30 28 22 080 1	0.3
CW 32	39 20 110 032 01	0.5

D'ANDREA



- TOOLHOLDERS FOR TESTAROSSA
- WERKZEUGE FÜR TESTAROSSA
- PORTAHERRAMIENTAS PARA TESTAROSSA
- PORTE-OUTILS POUR TESTAROSSA
- PORTAUTENSILI PER TESTAROSSA

P 22
Ø 40 ~ 74

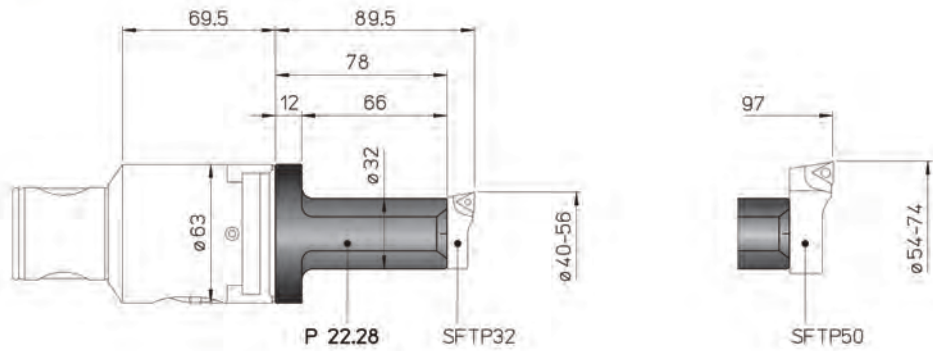

REF.	CODE	Ø
P 22.28	43 30 28 22 063 1	0.45

- BIT-HOLDERS FOR TESTAROSSA
- PLATTENHALTER FÜR TESTAROSSA
- PORTA-PLAQUITAS PARA TESTAROSSA
- PORTE-PLAQUETTES POUR TESTAROSSA
- SEGGI PER TESTAROSSA

SF

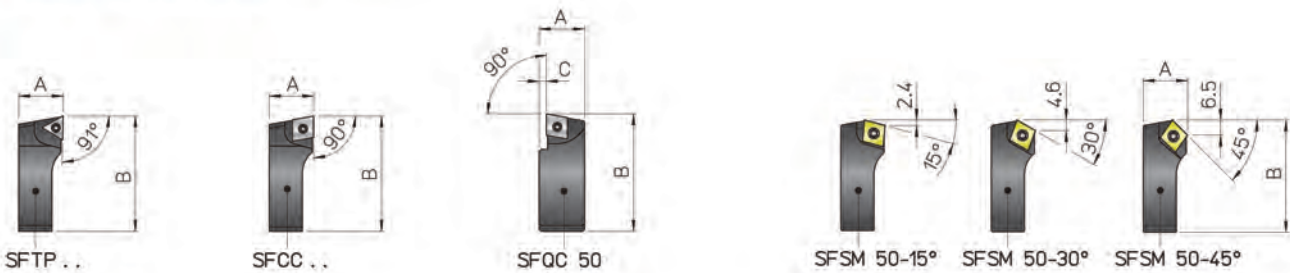

REF.	CODE	A	B	C	△	⊖	⊔	⌘	Kg.
SFTP 32	47 050 05 32 001	11.5	34.5	-	TPGX 0902..	-	CS 250T	TORX T08	0.02
SFTP 50	47 050 05 50 001	19	52	-	TPGX 1103..	-	CS 300890T	TORX T08	0.08
SFCC 50	47 050 05 50 002	19	52	-	-	CCGT 09T3..	TS 4	TORX T15	0.08
SFQC 50	47 050 05 50 062	20.5	53	3	-	CCMT 09T3..	TS 4	TORXT15	0.1
SF5M 50-15°	47 050 05 50 011	19	50.5	-	-	CCMT 09T3..	TS 4	TORXT15	0.07
SF5M 50-30°	47 050 05 50 013								
SF5M 50-45°	47 050 05 50 015								

D'ANDREA

D'ANDREA MODULHARD'ANDREA

TRC 80 Ø 6 ~ 200

• TESTAROSSA



10 µm
nonio
vernier **2 µm**

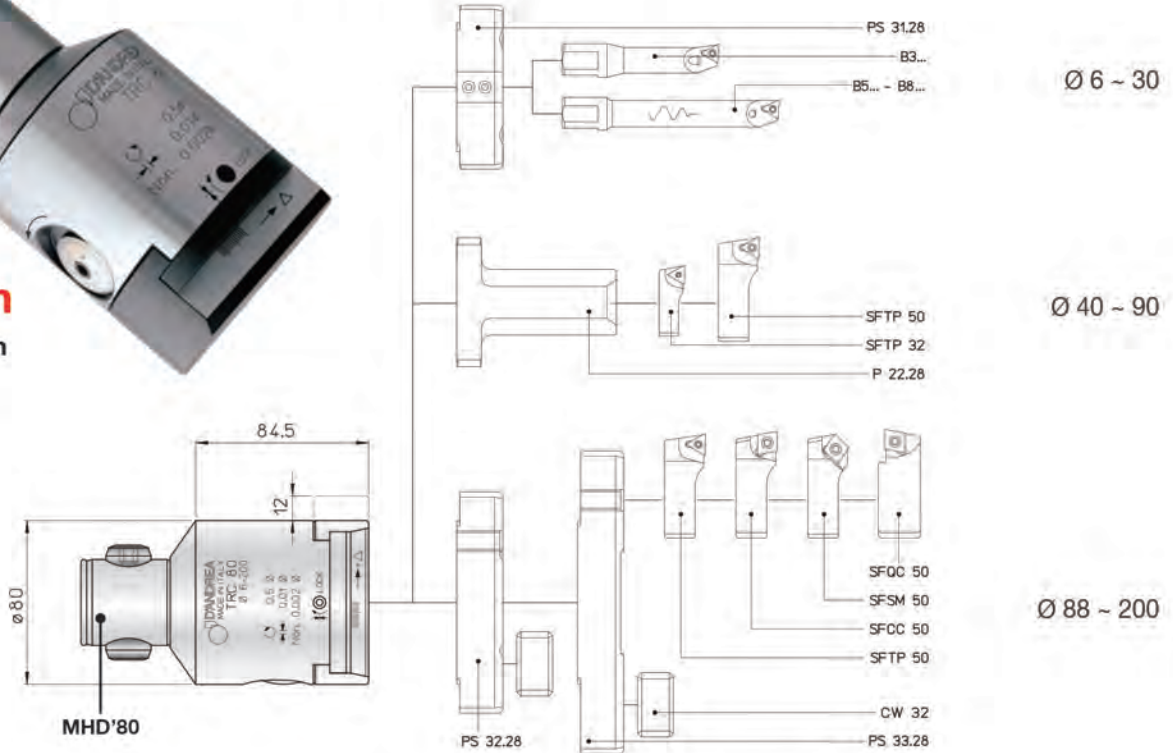

REF.	CODE	Kg.
TRC 80	45 50 180 0120 1	3.8

KIT K01
Ø 6 ~ 200

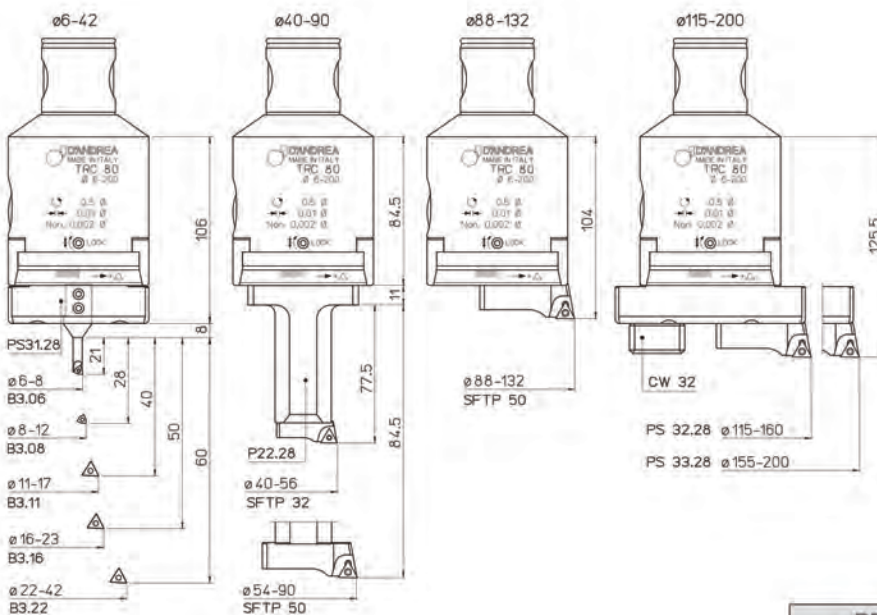

K01 TRC 80		
1 TRC 80	1 B3.06	1 SFTP32
1 PS31.28	1 B3.08	1 SFTP50
1 PS32.28	1 B3.11	
1 PS33.28	1 B3.16	
1 CW 32	1 B3.22	
1 P22.28		
5 TPGX 090202L DC100		
1 TPGX 110302L DC100		
2 WCGT 020102L DC100		

REF.	CODE	Ø
K01 TRC 80	65 50 180 1080 2	6 ~ 200

D'ANDREA



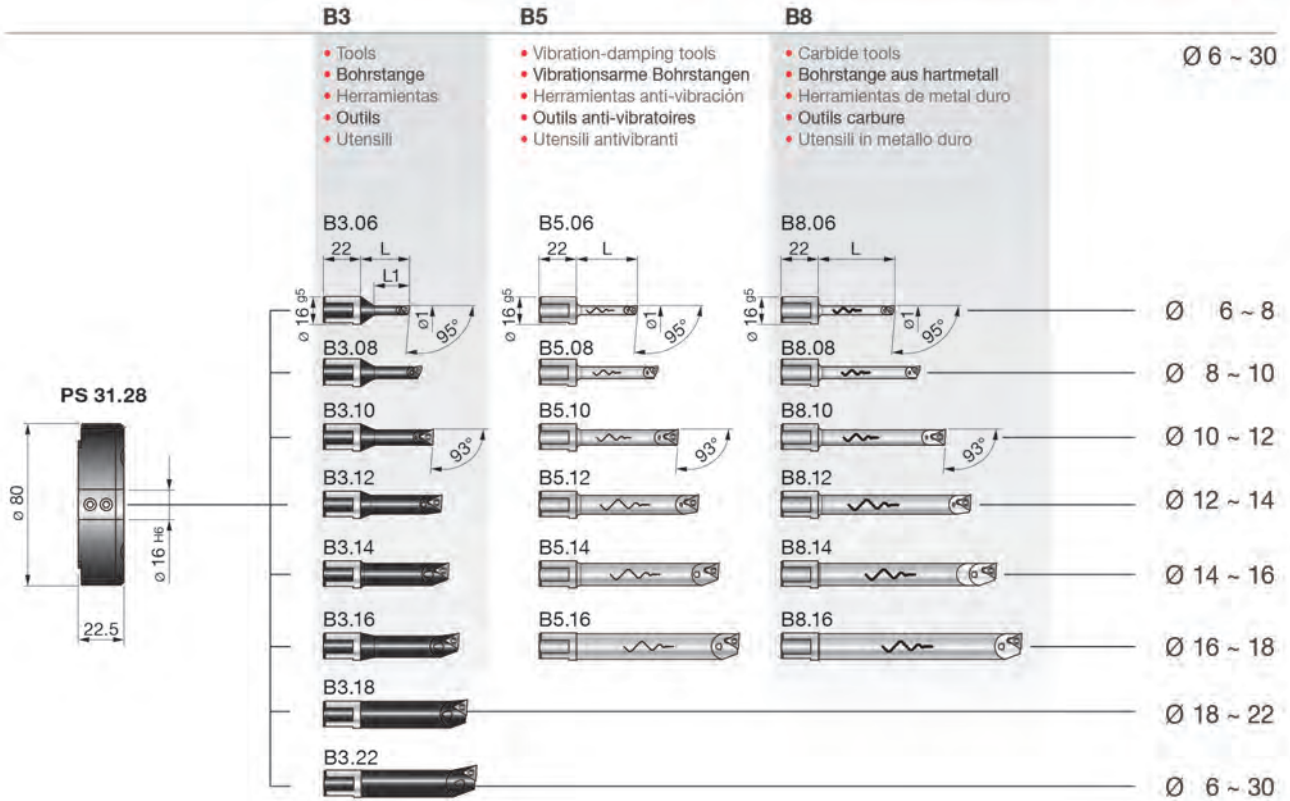

REF.	CODE	Kg.
PS 31.28	43 30 28 22 080 1	0.3

REF.	CODE	Ø1	L	L1	⚠	⚠	🔩	🔩	Kg.
B3.06	57 201 05 06 001	6 - 8	29	21	WCGT 0201..	-	TS 21	TORX T06	0.035
B3.08	57 201 05 08 001	8 - 10	36	28			TS 211		0.04
B3.10	57 201 05 10 001	10 - 12	43	35	-	TPGX 0902..	CS 250 T	TORX T08	0.05
B3.11	57 201 05 11 001	11 - 13	48	40					0.055
B3.12	57 201 05 12 001	12 - 14	48	42					0.06
B3.14	57 201 05 14 001	14 - 16	52	50					0.07
B3.16	57 201 05 16 001	16 - 18	58	-	-	TPGX 0902..	CS 250 T	TORX T08	0.1
B3.18	57 201 05 18 001	18 - 22	63	-					0.2
B3.22	57 201 05 22 001	22 - 30	68	-					0.3
B5.06	57 201 05 06 105	6 - 8	36	-	WCGT 0201..	-	TS 21	TORX T06	0.075
B5.08	57 201 05 08 105	8 - 10	48	-			TS 211		0.09
B5.10	57 201 05 10 105	10 - 12	60	-	-	TPGX 0902..	CS 250 T	TORX T08	0.1
B5.12	57 201 05 12 105	12 - 14	72	-					0.2
B5.14	57 201 05 14 105	14 - 16	84	-					0.3
B5.16	57 201 05 16 105	16 - 18	96	-					0.3
B8.06	57 201 05 06 108	6 - 8	45	-	WCGT 0201..	-	TS 21	TORX T06	0.065
B8.08	57 201 05 08 108	8 - 10	60	-			TS 211		0.08
B8.10	57 201 05 10 108	10 - 12	75	-	-	TPGX 0902..	CS 250 T	TORX T08	0.1
B8.12	57 201 05 12 108	12 - 14	90	-					0.2
B8.14	57 201 05 14 108	14 - 16	105	-					0.3
B8.16	57 201 05 16 108	16 - 18	120	-					0.3

D'ANDREA

D'ANDREA MODULHARD'ANDREA

TRC 80 Ø 85 ~ 202.5

- TOOLHOLDERS FOR TESTAROSSA
- WERKZEUGE FÜR TESTAROSSA
- PORTAHERRAMIENTAS PARA TESTAROSSA
- PORTE-OUTILS POUR TESTAROSSA
- PORTAUTENSILI PER TESTAROSSA

PS
CW 32
Ø 88- 200

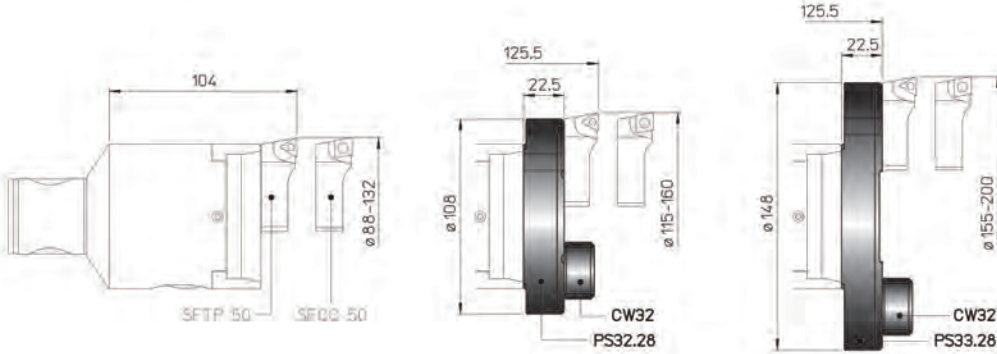

PS
Ø 88.5 ~ 202.5

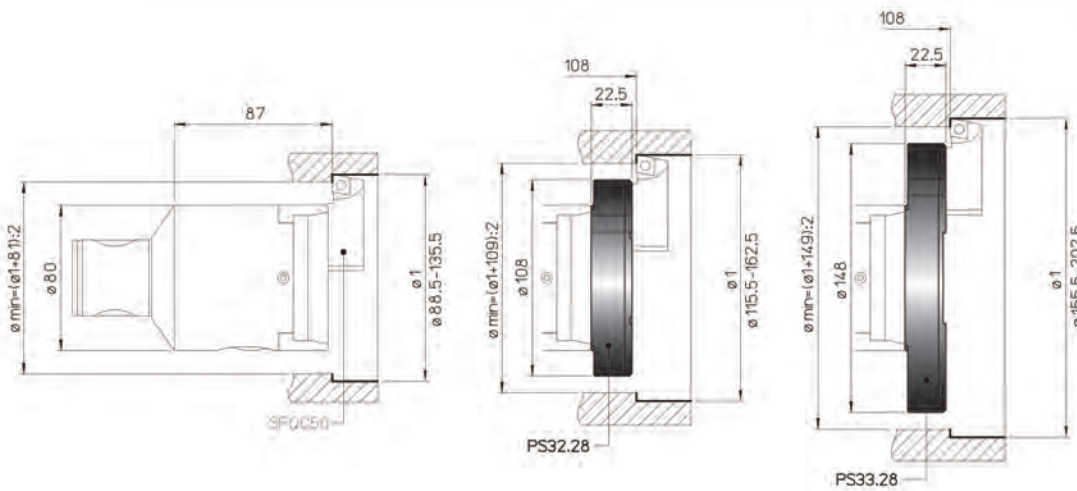

PS
Ø 85 ~ 200

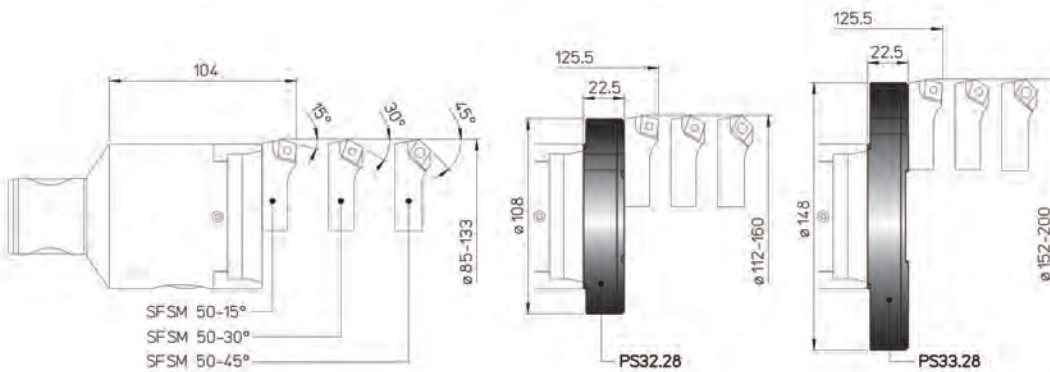

REF.	CODE	Kg.
PS 32.28	43 30 28 22 108 1	0.5
PS 33.28	43 30 28 22 148 1	0.6
CW 32	39 20 110 032 01	0.5



- TOOLHOLDERS FOR TESTAROSSA
- WERKZEUGE FÜR TESTAROSSA
- PORTAHERRAMIENTAS PARA TESTAROSSA
- PORTE-OUTILS POUR TESTAROSSA
- PORTAUTENSILI PER TESTAROSSA

P 22
Ø 40 ~ 90

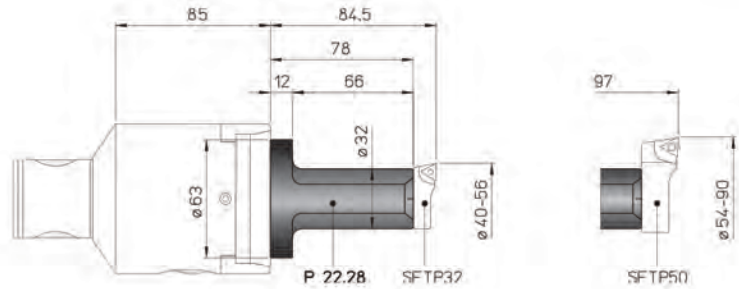

REF.	CODE	Kg.
P 22.28	43 30 28 22 063 1	0.45

- BIT-HOLDERS FOR TESTAROSSA
- PLATTENHALTER FÜR TESTAROSSA
- PORTA-PLAQUITAS PARA TESTAROSSA
- PORTE-PLAQUETTES POUR TESTAROSSA
- SEGGI PER TESTAROSSA

SF

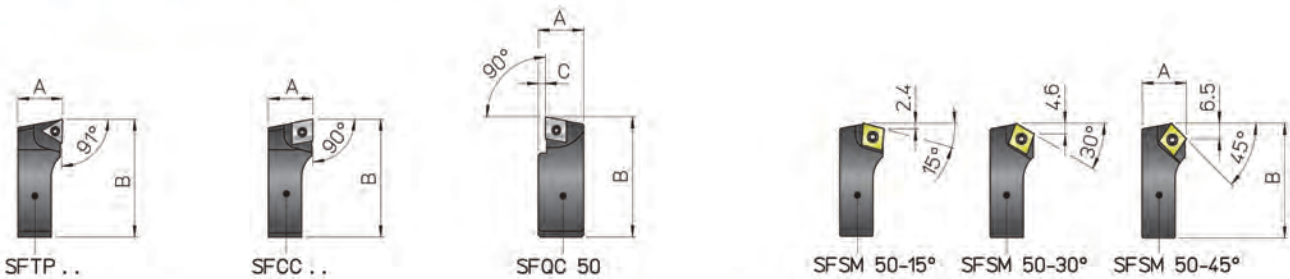

REF.	CODE	A	B	C	△	□	⊥	⊞	Kg.
SFTP 32	47 050 05 32 001	11.5	34.5	-	TPGX 0902..	-	CS 250T	TORX T08	0.02
SFTP 50	47 050 05 50 001	19	52	-	TPGX 1103..	-	CS 300890T		0.08
SFCC 50	47 050 05 50 002	19	52	-	-	CCGT 09T3..	TS 4	TORX T15	0.08
SFQC 50	47 050 05 50 062	20.5	53	3	-	CCMT 09T3..	TS 4	TORXT15	0.1
SF5M 50-15°	47 050 05 50 011	19	50.5	-	-	CCMT 09T3..	TS 4	TORXT15	0.07
SF5M 50-30°	47 050 05 50 013								
SF5M 50-45°	47 050 05 50 015								

TRC HS

RPM MAX 12.000

Ø 2.5 ~ 22

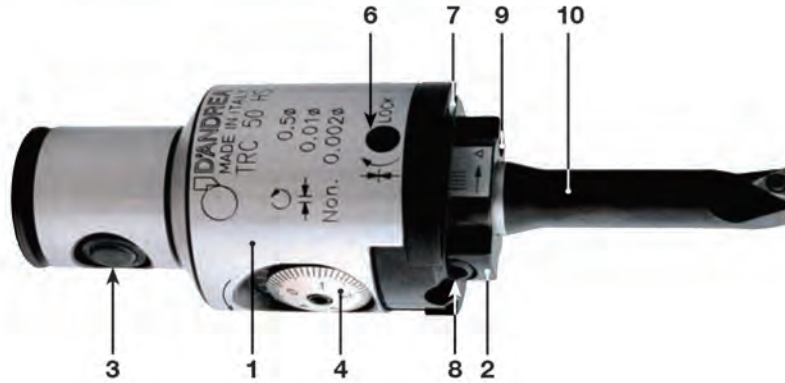

10 µm
nonio
vernier 2 µm



- 1 • Body
• Körper
• Cuerpo
• Corps
• Corpo
- 2 • Slide toolholder
• Werkzeugschlitten
• Guía portaherramientas
• Coulisseau
• Slitta portautensili
- 3 • Expanding radial pin
• Spreizbolzen
• Perno radial expansible
• Tige radiale expansible
• Perno radiale espandibile
- 4 • Vernier scale
• Nonius
• Nonio
• Vernier
• Nonio
- 5 • Micrometric vernier scale
• Mikrometrischer Nonius
• Nonio micrométrico
• Vernier micrométrique
• Nonio micrometrico

TRC 32 HS
Ø 2.5 ~ 18



TRC 50 HS
Ø 2.5 ~ 22



KR IT6 공차의 매우 정교한 작업 또는 우수한 표면 조도가 요한 작업은 TRC HS HEAD 사용으로 해결할 수 있습니다. TRC HS HEAD 는 매우 정교하며 5 마이크로미터의 Radial 조정은 눈금으로 쉽게 읽을 수 있고 장비에서 즉시 효과를 확인 할 수 있습니다.

GB FEATURES. High precision work to IT6 tolerance, with excellent surface finish, is achieved using TRC HS boring heads. These are very sensitive and radial correction of 5 micron can be effected directly on the machine and easily read on the vernier scale.

D MERKMALE. Die TRC HS Köpfe ermöglichen Bearbeitungen mit hoher Präzision und Toleranzen mit Grad IT6 bei hochwertiger Oberflächengüte. Sie besitzen eine Feinverstellung mit einer Genauigkeit von radial 5 µm, wobei das Maß auf der Skala abgelesen und auch direkt an der Maschine eingestellt werden kann.

E CARACTERÍSTICAS. Los cabezales TRC HS permiten realizar operaciones de alta precisión con tolerancias de grado IT6 con un extraordinario acabado de la superficie. Tienen una sensibilidad de ajuste de 5 micras en radio, de fácil lectura en el nonio y corregibles directamente sobre la máquina.

I CARATTERISTICHE. Le testine TRC HS consentono lavorazioni di alta precisione con tolleranze di grado IT6 con ottima finitura superficiale. Hanno una sensibilità di regolazione di 5 micron sul raggio, facilmente leggibile sul nonio ed eseguibile anche in macchina.



TRM HSB
RPM MAX 20.000
Ø 2.5 ~ 22

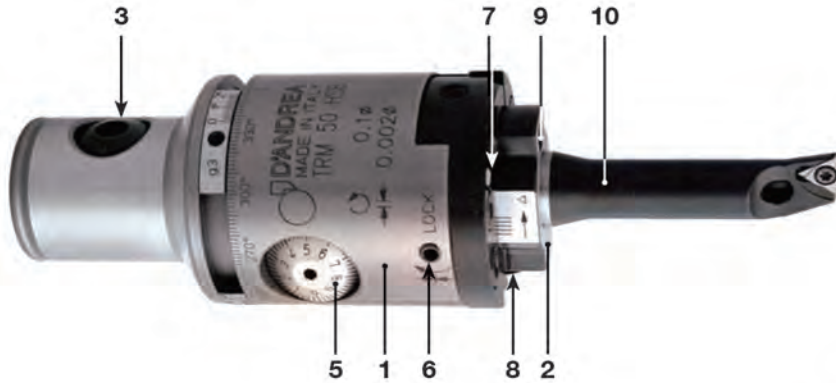

2 µm



- 6
 - Slide clamp screw
 - Schlittenklemmschraube
 - Tornillo bloqueo guía
 - Vis blocage coulisseau
 - Vite bloccaggio slitta
- 7
 - Coolant outlet
 - Kühlmittelaustritt
 - Agujero salida refrigerante
 - Sortie du liquide d'arrosage
 - Uscita refrigerante
- 8
 - Tools clamp screws
 - Werkzeugklemmschrauben
 - Tornillo bloqueo herramienta
 - Vis blocage outil
 - Viti bloccaggio utensile
- 9
 - Oiler
 - Schmiernippel
 - Engrasador
 - Graisseur
 - Oliatore
- 10
 - Tool
 - Werkzeug
 - Herramienta
 - Outil
 - Utensile

TRM 32 HSB
Ø 2.5 - 18



TRM 50 HSB
Ø 2.5 - 22

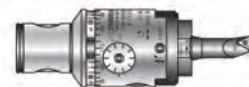

KR IT6 공차의 매우 정교한 작업 또는 우수한 표면 조도가 요한 작업은 TRM HSB HEAD 사용으로 해결할 수 있습니다. TRM HSB HEAD 는 매우 정교하며 1 마이크로미터의 Radial 조정은 눈금으로 쉽게 읽을 수 있고 장비에서 즉시 효과를 확인 할 수 있습니다.

GB FEATURES. High precision work to IT6 tolerance, with excellent surface finish, is achieved using TRM HSB boring heads. These are very sensitive and radial correction of 1 micron can be effected directly on the machine and easily read on the vernier scale.

D MERKMALE. Die TRM HSB Köpfe ermöglichen Bearbeitungen mit hoher Präzision und Toleranzen mit Grad IT6 bei hochwertiger Oberflächengüte. Sie besitzen eine Feinverstellung mit einer Genauigkeit von radial 1 µm, wobei das Maß auf der Skala abgelesen und auch direkt an der Maschine eingestellt werden kann.

E CARACTERÍSTICAS. Los cabezales TRM HSB permiten realizar operaciones de alta precisión con tolerancias de grado IT6 con un extraordinario acabado de la superficie. Tienen una sensibilidad de ajuste de 1 micras en radio, de fácil lectura en el nonio y corregibles directamente sobre la máquina.

I CARATTERISTICHE. Le testine TRM HSB consentono lavorazioni di alta precisione con tolleranze di grado IT6 con ottima finitura superficiale. Hanno una sensibilità di regolazione di 1 micron sul raggio, facilmente leggibile sul nonio ed eseguibile anche in macchina.

TRC 32 HS TRM 32 HSB Ø 2.5 ~ 18



10 µm
nonio
vernier **2 µm**

TRC 32 HS
Ø 2.5 - 18
RPM MAX 12.000



2 µm

TRM 32 HSB
Ø 2.5 - 18
RPM MAX 20.000

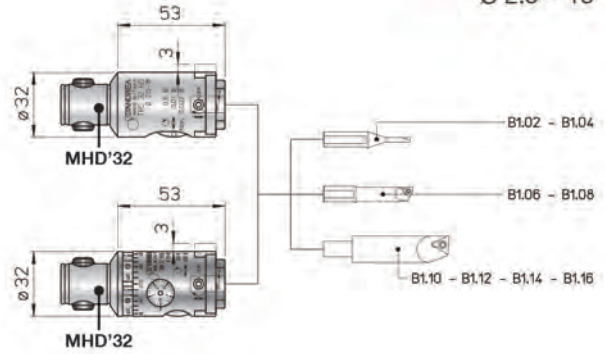

REF.	CODE	Kg.
TRC 32 HS	45 50 332 0053 1	0.35
TRM 32 HSB	45 51 032 0053 1	

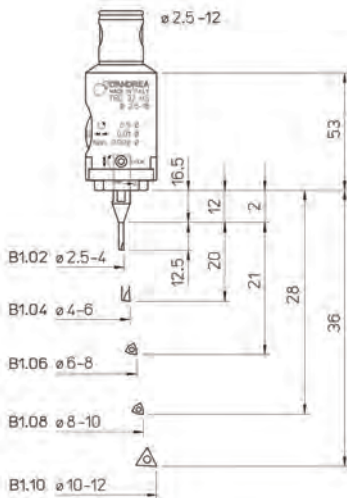

KIT K01 TRC 32 HS Ø 2.5 ~ 12



K01 TRC 32 HS		
1 TRC32HS	1 B1.04	1 B1.08
1 B1.02	1 B1.06	1 B1.10
5 TPGX 090202L DC100		
2 WCGT 020102L DC100		

REF.	CODE	Ø
K01 TRC 32 HS	65 50 332 3032 2	2.5 - 12

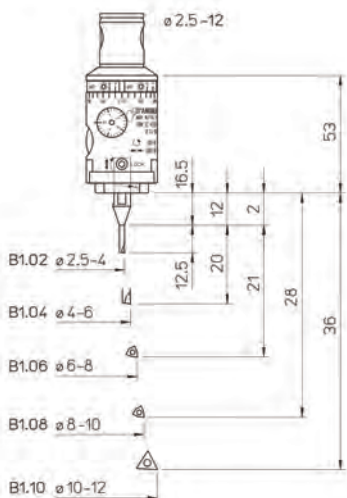

KIT K01 TRM 32 HSB Ø 2.5 ~ 12



K01 TRM 32 HSB		
1 TRM32HSB	1 B1.04	1 B1.08
1 B1.02	1 B1.06	1 B1.10
5 TPGX 090202L DC100		
2 WCGT 020102L DC100		

REF.	CODE	Ø
K01 TRM 32 HSB	65 50 032 3032 1	2.5 - 12



TRC 32 HS TRM 32 HSB Ø 2.5 ~ 18

testarossadandrea

B1

- Carbide tools
- Bohrstanze aus hartmetall
- Herramientas de metal duro
- Outils carbure
- Utensili in metallo duro

B1

- Tools
- Bohrstanze
- Herramientas
- Outils
- Utensili

Ø 2.5 ~ 22

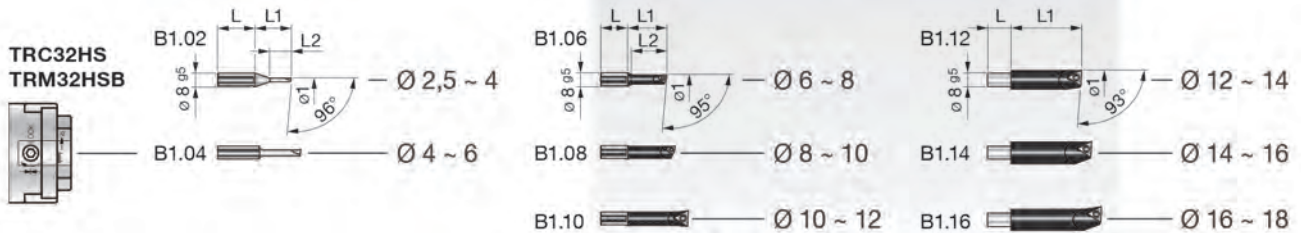

REF.	CODE	Ø1	L	L1	L2	Kg.
B1.02	57 201 05 02 001	2.5 - 4	22	21	12.5	0.02
B1.04	57 201 05 04 001	4 - 6	24	24	-	

REF.	CODE	Ø1	L	L1	L2	⚠	⚠	🔩	🔩	Kg.
B1.06	57 201 05 06 000	6 - 8	16	23	21	WCGT 0201..	-	TS 21	TORX T06	0.01
B1.08	57 201 05 08 000	8 - 10		28	-			TS 211		0.015
B1.10	57 201 05 10 000	10 - 12		36				0.02		
B1.12	57 201 05 12 000	12 - 14	14	42	-	TPGX 0902..	CS 250 T	TORX T08	0.03	
B1.14	57 201 05 14 000	14 - 16		48					0.04	
B1.16	57 201 05 16 000	16 - 18		54					0.05	



10 μm
nonio
vernier **2 μm**

TRC 50 HS
Ø 2.5 ~ 22
RPM MAX 12.000

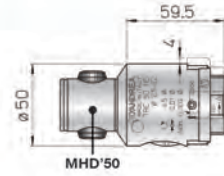

**TRC 50 HS
TRM 50 HSB**
Ø 2.5 ~ 22



2 μm

TRM 50 HSB
Ø 2.5 ~ 22
RPM MAX 20.000

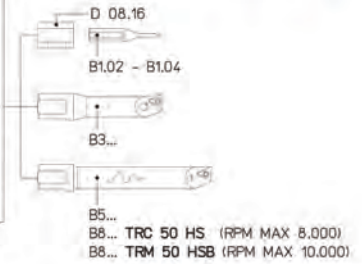
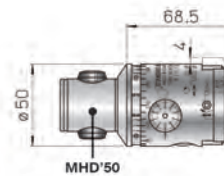

REF.	CODE	Kg.
TRC 50 HS	45 50 350 0060 1	1
TRM 50 HSB	45 51 050 0070 1	1.4

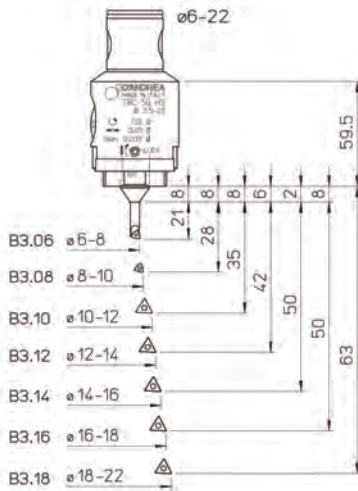

**KIT K01
TRC 50 HS**
Ø 6 ~ 22



K01 TRC 50 HS		
1 TRC50HS	1 B3.10	1 B3.16
1 B3.16	1 B3.12	1 B3.18
1 B3.08	1 B3.14	
5 TPGX 090202L DC100		
2 WCGT 020102L DC100		

REF.	CODE	Ø
K01 TRC 50 HS	65 50 350 3050 2	6 ~ 22

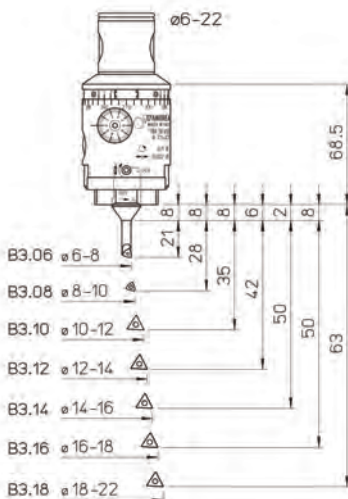

**KIT K01
TRM 50 HSB**
Ø 6 ~ 22



K01 TRM 50 HSB		
1 TRM50HSB	1 B3.10	1 B3.16
1 B3.06	1 B3.12	1 B3.18
1 B3.08	1 B3.14	
5 TPGX 090202L DC100		
2 WCGT 020102L DC100		

REF.	CODE	Ø
K01 TRM 50 HSB	65 50 050 3050 1	6 ~ 22



TRC 32 HS TRM 32 HSB Ø 2.5 ~ 22

testarossad'andrea

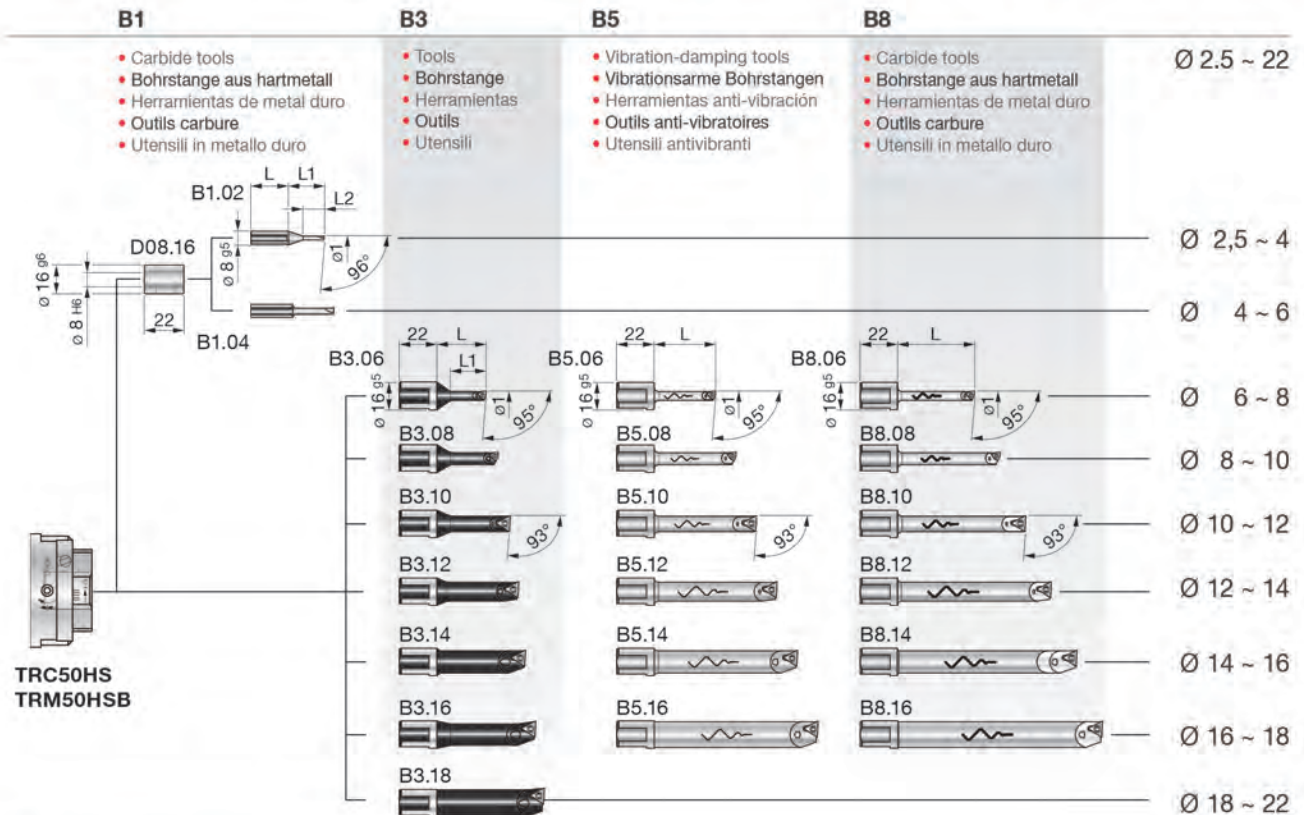

TRC50HS
TRM50HSB

REF.	CODE	Kg.
D08.16	20 056 01 16 08 2	0.02

REF.	CODE	Ø1	L	L1	L2	Kg.
B1.02	57 201 05 02 001	2.5 - 4	22	21	12.5	0.02
B1.04	57 201 05 04 001	4 - 6	24	24	-	

REF.	CODE	Ø1	L	L1	△	△	⌋	⌋	Kg.
B3.06	57 201 05 06 001	6 - 8	29	21	WCGT 0201..	-	TS 21	TORX T06	0.035
B3.08	57 201 05 08 001	8 - 10	36	28					TS 211
B3.10	57 201 05 10 001	10 - 12	43	35	-	TPGX 0902..	CS 250 T	TORX T08	0.05
B3.11	57 201 05 11 001	11 - 13	40	42					0.055
B3.12	57 201 05 12 001	12 - 14	48						0.06
B3.14	57 201 05 14 001	14 - 16	52	50					0.07
B3.16	57 201 05 16 001	16 - 18	58	-					0.1
B3.18	57 201 05 18 001	18 - 22	63	-					0.1

B5.06	57 201 05 06 105	6 - 8	36	-	WCGT 0201..	-	TS 21	TORX T06	0.075
B5.08	57 201 05 08 105	8 - 10	48						TS 211
B5.10	57 201 05 10 105	10 - 12	60	-	TPGX 0902..	CS 250 T	TORX T08	0.1	
B5.12	57 201 05 12 105	12 - 14	72					0.2	
B5.14	57 201 05 14 105	14 - 16	84					0.3	
B5.16	57 201 05 16 105	16 - 18	96						

B8.06	57 201 05 06 108	6 - 8	45	-	WCGT 0201..	-	TS 21	TORX T06	0.065
B8.08	57 201 05 08 108	8 - 10	60						TS 211
B8.10	57 201 05 10 108	10 - 12	75	-	TPGX 0902..	CS 250 T	TORX T08	0.1	
B8.12	57 201 05 12 108	12 - 14	90					0.2	
B8.14	57 201 05 14 108	14 - 16	105					0.3	
B8.16	57 201 05 16 108	16 - 18	120						

D'ANDREA



- 1 • Body
• Körper
• Cuerpo
• Corps
• Corpo
- 2 • Slide toolholder
• Werkzeugschlitten
• Guía portaherramientas
• Coulisseau
• Slitta portautensili
- 3 • Expanding radial pin
• Spreizbolzen
• Perno radial expansible
• Tige radiale expansible
• Perno radiale espandibile
- 4 • Micrometric vernier scale
• Mikrometrischer Nonius
• Nonio micrométrico
• Vernier micrométrique
• Nonio micrometrico
- 5 • Slide clamp screw
• Schlittenklemmschraube
• Tornillo bloqueo guía
• Vis blocage coulisseau
• Vite bloccaggio slitta
- 6 • Coolant outlet
• Kühlmittelaustritt
• Agujero salida refrigerante
• Sortie du liquide d'arrosage
• Uscita refrigerante
- 7 • Tools clamp screws
• Werkzeugklemmschraube
• Tornillo bloqueo herramientas
• Vis blocage outil
• Viti bloccaggio utensili

2 μm



- 8 • Oiler
• Schmiernippel
• Engrasador
• Graisseur
• Oliatore
- 9 • Bit holder
• Plattenhalter
• Portaplaquita
• Porte-plaquettes
• Seggio portainseriti
- 10 • Tool holder
• Werkzeughalter
• Portaherramienta
• Porte-outil
• Porta utensile

MR TRM HEAD 는 녹방지를 위해 특수 코팅으로 제작되었습니다. IT6 공차의 매우 정교한 작업 또는 우수한 표면 조도가 요한 작업은 TRM HEAD 사용으로 해결할 수 있습니다. TRM HEAD 는 매우 정교하며 1 마이크로미터의 Radial 조정은 눈금으로 쉽게 읽을 수 있고 장비에서 즉시 효과를 확인 할 수 있습니다.

BB FEATURES. The TRM heads in the D'Andrea Testarossa line have protective rustproof coating. High precision work to IT6 tolerance, with excellent surface finish, is achieved using TRM boring heads. These are very sensitive and radial correction of 1 micron can be effected directly on the machine and easily read on the vernier scale.

D MERKMALE. Die TRM Köpfe der Testarossa-Serie besitzen eine rostbeständige Oberfläche. Die TRM-Köpfe ermöglichen ermöglichen Bearbeitungen mit hoher Präzision und Toleranzen mit Grad IT6 bei hochwertiger Oberflächengüte. Sie besitzen eine Feinverstellung mit einer Genauigkeit von radial 1 μm, wobei das Maß auf der Skala abgelesen und auch direkt an der Maschine eingestellt werden kann.

E CARACTERÍSTICAS. Los cabezales TRM de la línea Testarossa D'Andrea cuentan con una protección superficial anticorrosión. Los cabezales TRM permiten realizar operaciones de alta precisión con tolerancias de grado IT6 con un extraordinario acabado de la superficie. Tienen una sensibilidad de ajuste de 1 micra en radio, de fácil lectura en el nonio y corregibles directamente sobre la máquina.

I CARATTERISTICHE. Le testine TRM della linea Testarossa D'Andrea hanno una protezione superficiale anticorrosiva. Le testine TRM consentono lavorazioni di alta precisione con tolleranze di grado IT6 con ottima finitura superficiale. Hanno una sensibilità di regolazione di 1 micron sul raggio, facilmente leggibile sul nonio ed eseguibile anche in macchina.



TRM Ø 2.5 ~ 500

testarossadandrea

TRM 16

Ø 18 ~ 23



TRM 20

Ø 22 ~ 29



TRM 25

Ø 28 ~ 38



TRM 32

Ø 35.5 ~ 50



TRM 40

Ø 48 ~ 63

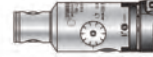

TRM 50

Ø 2.5 ~ 108



TRM 50/63

Ø 6 ~ 125



TRM 63/63

Ø 6 ~ 125



TRM 50/80

Ø 6 ~ 160



TRM 80/80

Ø 6 ~ 160



TRM 80/125

Ø 36 ~ 500



D'ANDREA



D'ANDREA MODULHARD'ANDREA

TRM 16-40 Ø 18 - 63

• TESTAROSSA

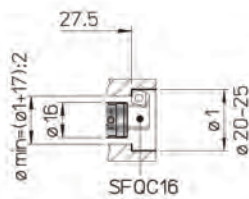
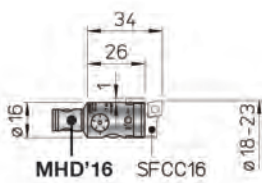
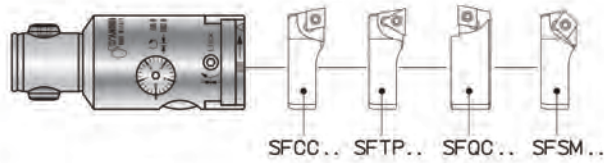

TRM 16
Ø 18 - 23

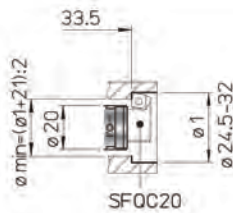
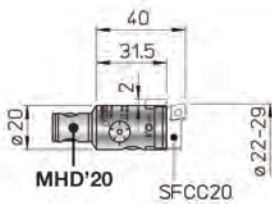

TRM 20
Ø 22 - 29

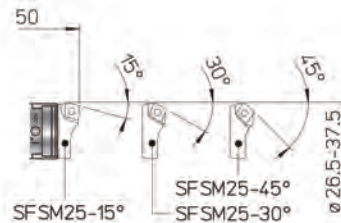
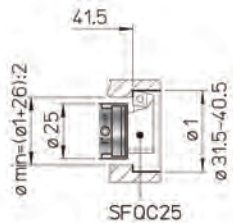
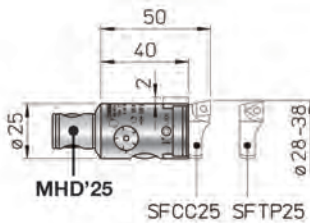

TRM 25
Ø 28 - 38

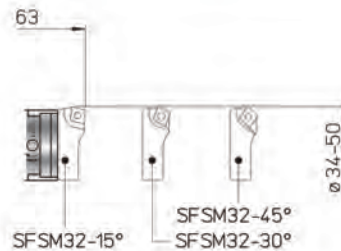
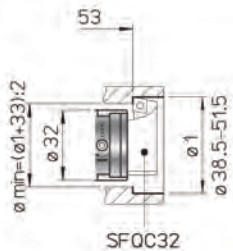
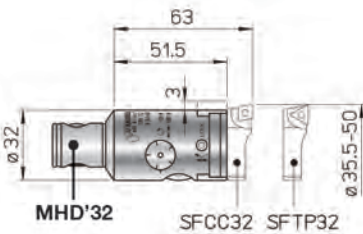

TRM 32
Ø 35.5 - 50

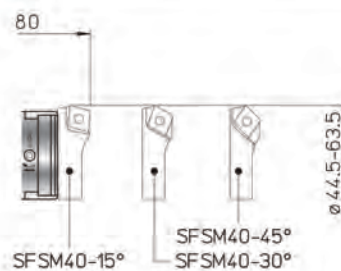
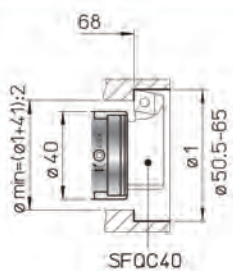
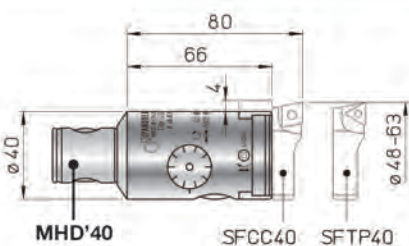

TRM 40
Ø 48 - 63



TRM



2 µm

REF.	CODE	Kg.
TRM 16	45 50 016 0034 1	0.05
TRM 20	45 50 020 0040 1	0.1
TRM 25	45 50 025 0050 0	0.2
TRM 32	45 50 032 0063 0	0.35
TRM 40	45 50 040 0080 0	0.7

- BIT-HOLDERS FOR TESTAROSSA
- PLATTENHALTER FÜR TESTAROSSA
- PORTA-PLAQUITAS PARA TESTAROSSA
- PORTE-PLAQUETTES POUR TESTAROSSA
- SEGGI PER TESTAROSSA

SF



REF.	CODE	A	B	C	L					Kg.
SFCC 16	47 050 05 16 002	8	17	-	-	CCGT 0602..	-	TS 25	TORX T08	0.003
SFCC 20	47 050 05 20 002	8.5	21	-	-					0.005
SFCC 25	47 050 05 25 002	10	26.5	-	-					0.01
SFCC 32	47 050 05 32 002	11.5	34.5	-	-					0.02
SFCC 40	47 050 05 40 002	14	44	-	-	CCGT 09T3..	-	TS 4	TORX T15	0.04
SFTP 25	47 050 05 25 001	10	26.5	-	-	-	TPGX 0902..	CS 250T	TORX T08	0.01
SFTP 32	47 050 05 32 001	11.5	34.5	-	-	-	TPGX 1103..	CS 300890T		0.02
SFTP 40	47 050 05 40 001	14	44	-	-	-	TPGX 1103..	CS 300890T		0.04
SFQC 16	47 050 05 16 062	10	18	2	-	-	CCMT 0602..	TS 25	TORX T08	0.005
SFQC 20	47 050 05 20 062	10.5	22.5							0.008
SFQC 25	47 050 05 25 062	12	28.5	2.5	-	-	CCMT 0602..	TS 25	TORX T08	0.01
SFQC 32	47 050 05 32 062	13.5	35.5							0.03
SFQC 40	47 050 05 40 062	16.5	46	3	-	-	CCMT 09T3..	TS 4	TORXT15	0.06
SFSM 25-15°	47 050 05 25 011	10	25.5	-	1.6	-	CCMT 0602..	TS 25	TORX T08	0.01
SFSM 25-30°	47 050 05 25 013				3					
SFSM 25-45°	47 050 05 25 015				4.3					
SFSM 32-15°	47 050 05 32 011	11.5	33.5	-	1.6	-	CCMT 0602..	TS 25	TORX T08	0.02
SFSM 32-30°	47 050 05 32 013				3					
SFSM 32-45°	47 050 05 32 015				4.3					
SFSM 40-15°	47 050 05 40 011	14	42.5	-	2.4	-	CCMT 09T3..	TS 4	TORXT15	0.03
SFSM 40-30°	47 050 05 40 013				4.6					
SFSM 40-45°	47 050 05 40 015				6.6					

D'ANDREA

D'ANDREA MODULHARD'ANDREA

TRM 50 Ø 2.5 ~ 108

• TESTAROSSA



2 µm

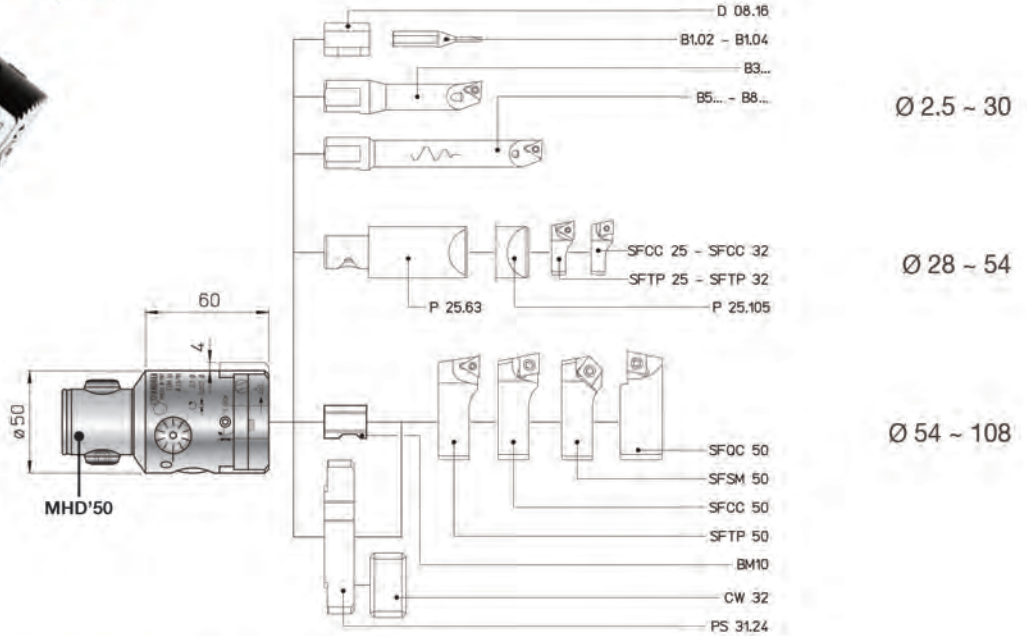

REF.	CODE	Kg.
TRM 50	45 50 050 0050 0	1

KIT K01
Ø 6 ~ 108

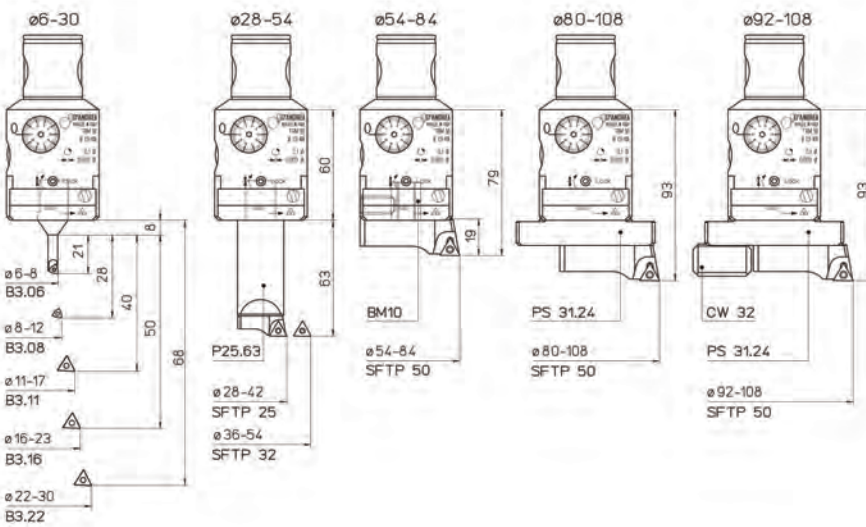

K01 TRM 50		
1 TRM 50	1 B3.06	1 SFTP25
1 P25.63	1 B3.08	1 SFTP32
1 BM10	1 B3.11	1 SFTP50
1 PS 31.24	1 B3.16	
1 CW 32	1 B3.22	
1 TPGX 110302L DC100		
5 TPGX 090202L DC100		
2 WCGT 020102L DC100		

REF.	CODE	Ø
K01 TRM 50	65 50 050 1050 1	6 ~ 108

D'ANDREA



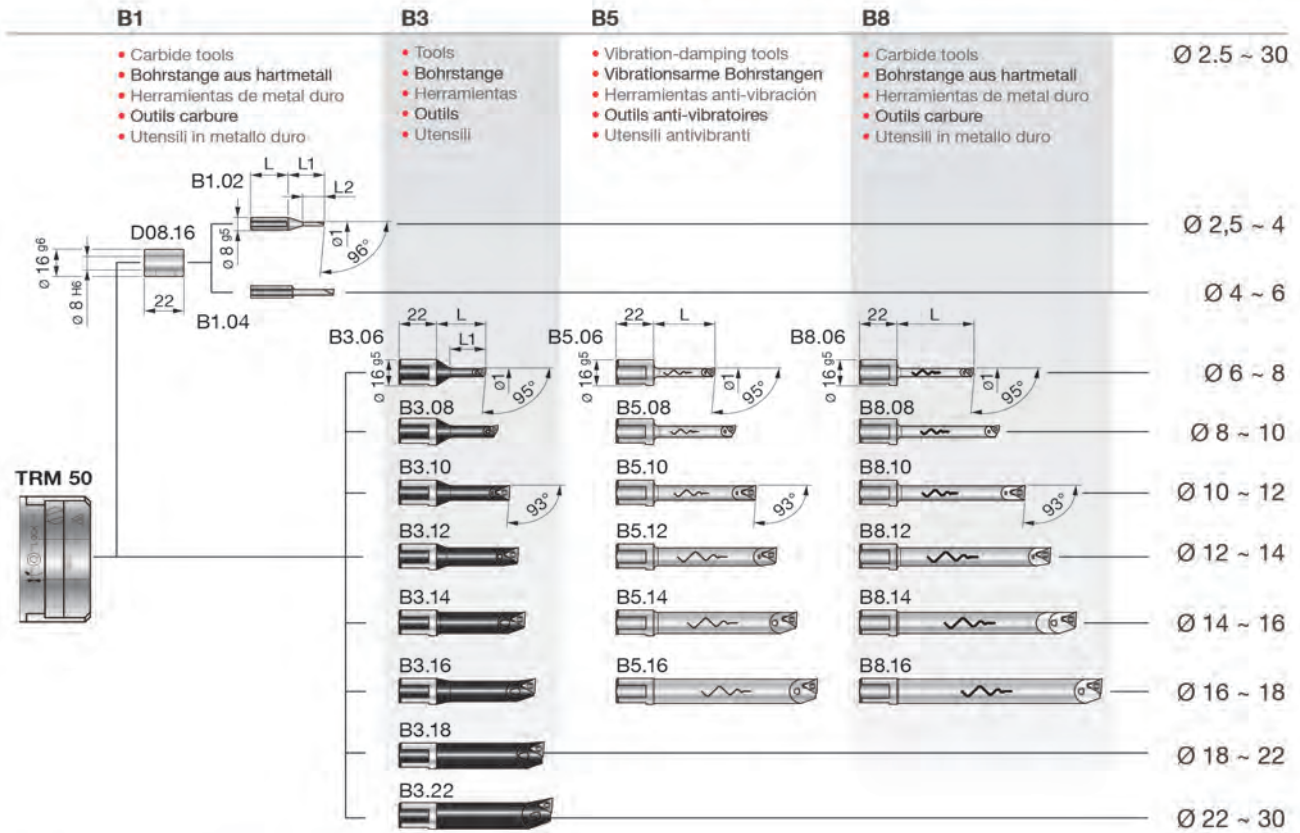

REF.	CODE	Kg.
D08.16	20 056 01 16 08 2	0.02

REF.	CODE	Ø1	L	L1	L2	Kg.
B1.02	57 201 05 02 001	2.5 ~ 4	22	21	12.5	0.02
B1.04	57 201 05 04 001	4 ~ 6	24	24	-	

REF.	CODE	Ø1	L	L1	△	△	⌋	⌋	Kg.
B3.06	57 201 05 06 001	6 ~ 8	29	21	WCGT 0201..	-	TS 21	TORX T06	0.035
B3.08	57 201 05 08 001	8 ~ 10	36	28					0.04
B3.10	57 201 05 10 001	10 ~ 12	43	35	-	TPGX 0902..	CS 250 T	TORX T08	0.05
B3.11	57 201 05 11 001	11 ~ 13	48	40					0.055
B3.12	57 201 05 12 001	12 ~ 14	48	42					0.06
B3.14	57 201 05 14 001	14 ~ 16	52	50					0.07
B3.16	57 201 05 16 001	16 ~ 18	58	-	-	-	-	-	0.1
B3.18	57 201 05 18 001	18 ~ 22	63	-					
B3.22	57 201 05 22 001	22 ~ 30	68	-					

B5.06	57 201 05 06 105	6 ~ 8	36	-	WCGT 0201..	-	TS 21	TORX T06	0.075
B5.08	57 201 05 08 105	8 ~ 10	48						0.09
B5.10	57 201 05 10 105	10 ~ 12	60	-	TPGX 0902..	CS 250 T	TORX T08	0.1	
B5.12	57 201 05 12 105	12 ~ 14	72					0.2	
B5.14	57 201 05 14 105	14 ~ 16	84					0.3	
B5.16	57 201 05 16 105	16 ~ 18	96						

B8.06	57 201 05 06 108	6 ~ 8	45	-	WCGT 0201..	-	TS 21	TORX T06	0.065
B8.08	57 201 05 08 108	8 ~ 10	60						0.08
B8.10	57 201 05 10 108	10 ~ 12	75	-	TPGX 0902..	CS 250 T	TORX T08	0.1	
B8.12	57 201 05 12 108	12 ~ 14	90					0.2	
B8.14	57 201 05 14 108	14 ~ 16	105					0.3	
B8.16	57 201 05 16 108	16 ~ 18	120						

TRM 50 Ø 52 ~ 108

- TOOLHOLDER FOR TESTAROSSA
- GRUNDHALTER FÜR TESTAROSSA
- PORTAHERRAMIENTAS PARA TESTAROSSA
- PORTE-OUTILS POUR TESTAROSSA
- PORTAUTENSILI PER TESTAROSSA

PS 31
CW 32
Ø 54 ~ 108

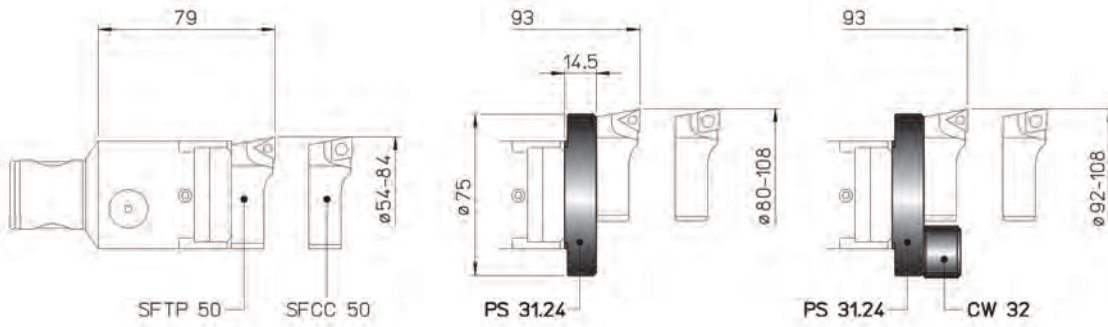

PS 31
Ø 56 ~ 111

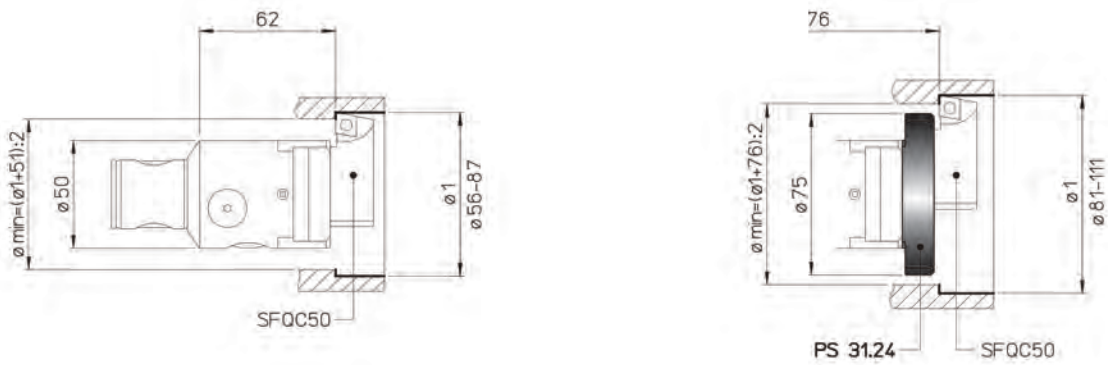

PS 31
Ø 52 ~ 109

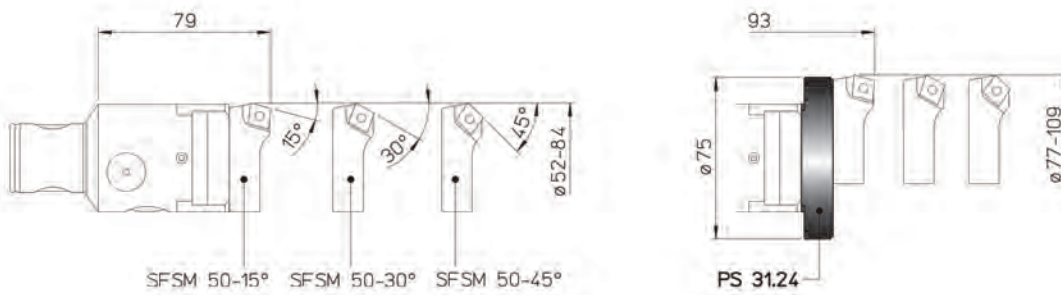

REF.	CODE	Kg.
PS 31.24	43 30 24 14 075 1	0.2
CW 32	39 20 110 032 01	0.5



- TOOLHOLDERS FOR TESTAROSSA
- GRUNDHALTER FÜR TESTAROSSA
- PORTAHERRAMIENTAS PARA TESTAROSSA
- PORTE-OUTILS POUR TESTAROSSA
- PORTAUTENSILI PER TESTAROSSA

PS 25
Ø 28 ~ 54

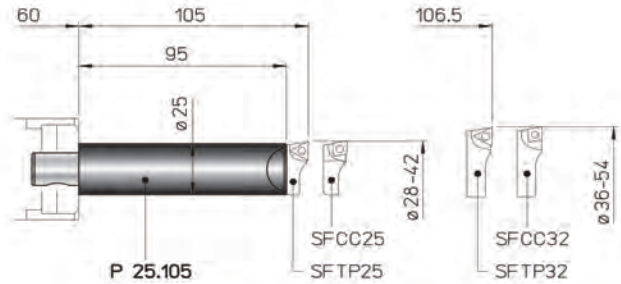
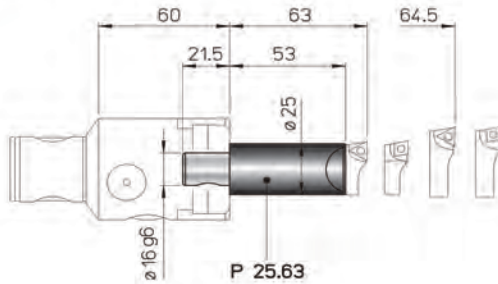

REF.	CODE	Kg.
P25.63	43 51 16 25 063 0	0.5
P25.105	43 51 16 25 105 0	0.8

- BIT-HOLDERS FOR TESTAROSSA
- PLATTENHALTER FÜR TESTAROSSA
- PORTA-PLAQUITAS PARA TESTAROSSA
- PORTE-PLAQUETTES POUR TESTAROSSA
- SEGGI PER TESTAROSSA

SF

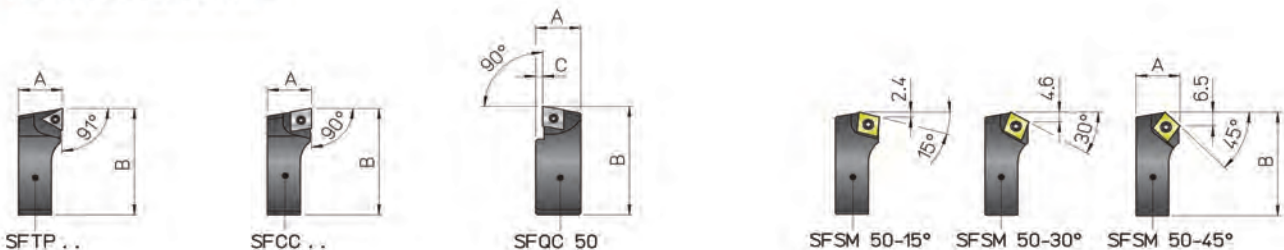

REF.	CODE	A	B	C	△	□	⌢	⌘	Kg.
SFTP 25	47 050 05 25 001	10	26.5	-	TPGX 0902..	-	CS 250T	TORX T08	0.01
SFTP 32	47 050 05 32 001	11.5	34.5	-	-	-	-		0.02
SFTP 50	47 050 05 50 001	19	52	-	TPGX 1103..	-	CS 300890T		0.08
SFCC 25	47 050 05 25 002	10	26.5	-	-	CCGT 0602..	TS 25	TORX T08	0.01
SFCC 32	47 050 05 32 002	11.5	34.5	-	-	CCGT 09T3..	TS 4	TORX T15	0.02
SFCC 50	47 050 05 50 002	19	52	-	-	CCGT 09T3..	TS 4	TORX T15	0.08
SFQC 50	47 050 05 50 062	20.5	53	3	-	CCMT 09T3..	TS 4	TORXT15	0.1
SFSM 50-15°	47 050 05 50 011	19	50.5	-	-	CCMT 09T3..	TS 4	TORXT15	0.07
SFSM 50-30°	47 050 05 50 013								
SFSM 50-45°	47 050 05 50 015								

D'ANDREA

D'ANDREA MODULHARD'ANDREA

TRM 50/63
TRM 63/63 Ø 2.5 ~ 125

• TESTAROSSA



TRM 50/63

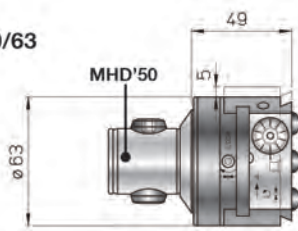

TRM 63/63

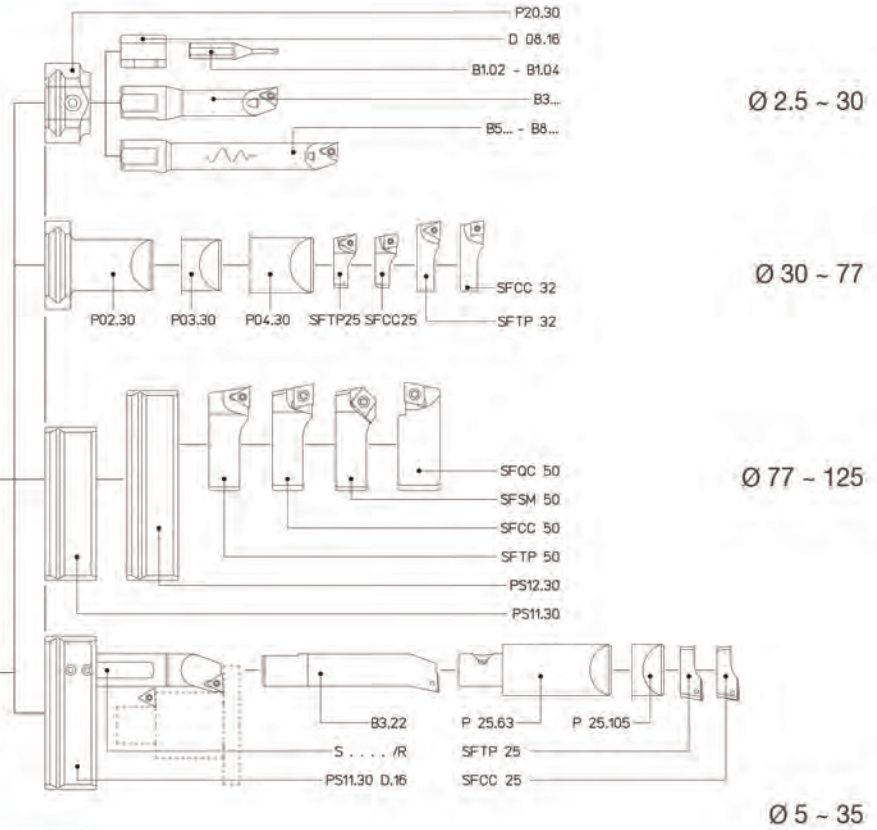
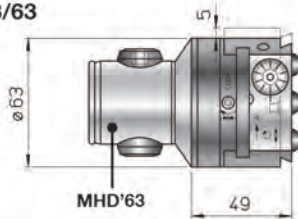

REF.	CODE	Kg.
TRM 50/63	45 50 050 0063 0	1.1
TRM 63/63	45 50 063 0063 0	1.5

KIT K01
Ø 6 - 125

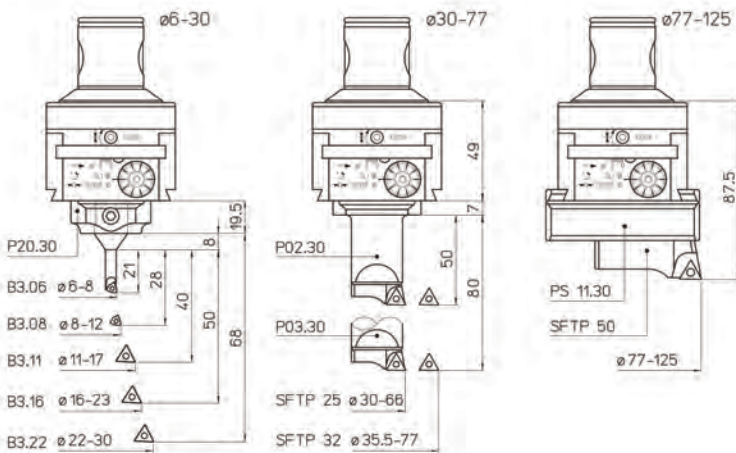

K01 TRM 50/63 - 63/63			
1 TRM.../ 63			
1 P20.30	1 P02.30	1 SFTP25	1 B3.06
1 PS11.30	1 P03.30	1 SFTP32	1 B3.08
5 TPGX 090202L DC100	1 SFTP50	1 B3.11	
1 TPGX 110302L DC100		1 B3.16	
2 WCGT 020102L DC100		1 B3.22	

REF.	CODE	Ø
K01 TRM 50/63	65 50 050 1063 1	6 ~ 125
K01 TRM 63/63	65 50 063 1063 1	



TRM 50/63
TRM 63/63 Ø 2.5 ~ 30

testarossadandrea

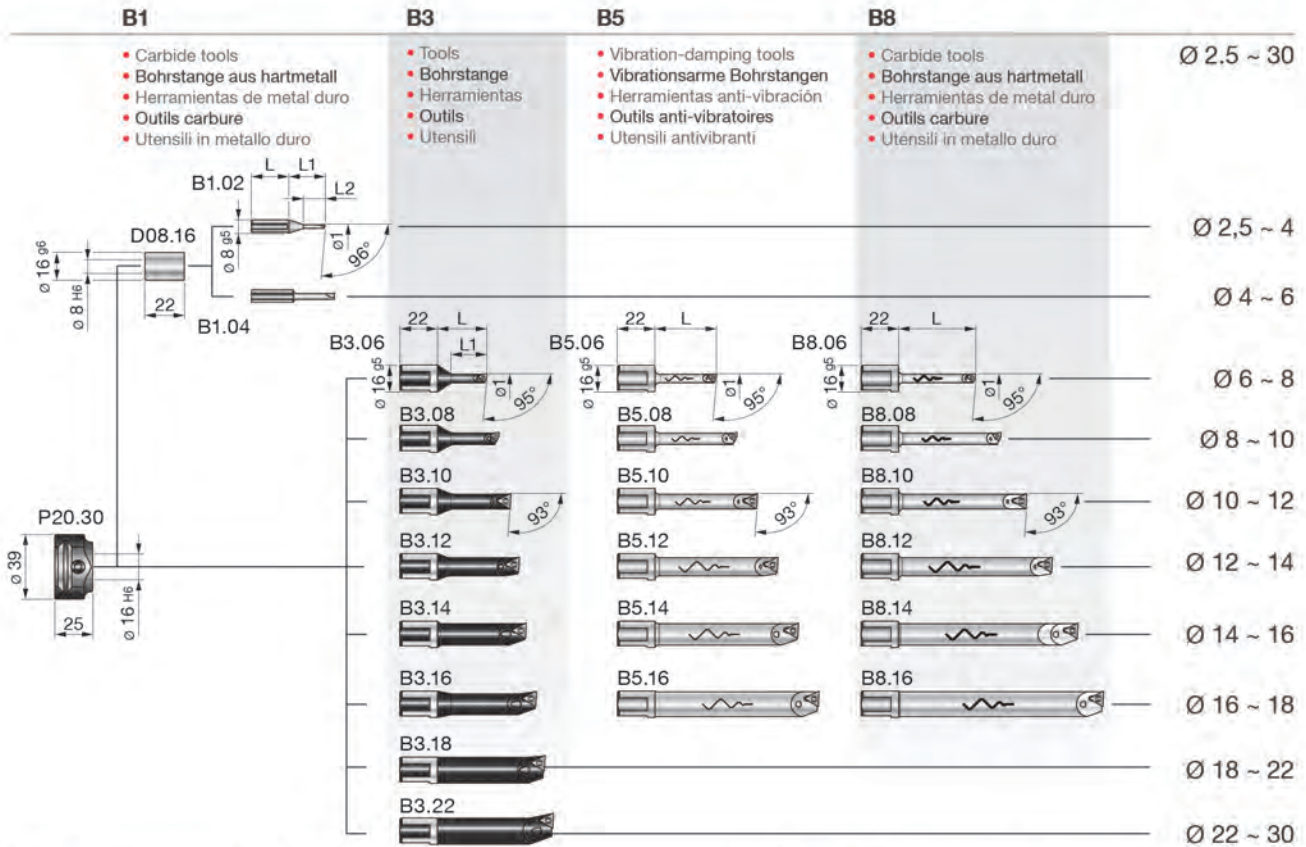

B1

- Carbide tools
- Bohrstange aus hartmetall
- Herramientas de metal duro
- Outils carbure
- Utensili in metallo duro

B3

- Tools
- Bohrstange
- Herramientas
- Outils
- Utensili

B5

- Vibration-damping tools
- Vibrationsarme Bohrstangen
- Herramientas anti-vibración
- Outils anti-vibratoires
- Utensili antivibranti

B8

- Carbide tools
- Bohrstange aus hartmetall
- Herramientas de metal duro
- Outils carbure
- Utensili in metallo duro

Ø 2.5 ~ 30

Ø 2,5 ~ 4

Ø 4 ~ 6

Ø 6 ~ 8

Ø 8 ~ 10

Ø 10 ~ 12

Ø 12 ~ 14

Ø 14 ~ 16

Ø 16 ~ 18

Ø 18 ~ 22

Ø 22 ~ 30

REF.	CODE	Kg.
D08.16	20 056 01 16 08 2	0.02

REF.	CODE	Kg.
P20.30	43 10 30 16 030 0	0.2

REF.	CODE	Ø1	L	L1	L2	Kg.
B1.02	57 201 05 02 001	2.5 ~ 4	22	21	12.5	0.02
B1.04	57 201 05 04 001	4 ~ 6	24	24	-	

REF.	CODE	Ø1	L	L1	△	△	⌋	⌋	Kg.
B3.06	57 201 05 06 001	6 ~ 8	29	21	WCGT 0201..	-	TS 21	TORX T06	0.035
B3.08	57 201 05 08 001	8 ~ 10	36	28			TS 211		0.04
B3.10	57 201 05 10 001	10 ~ 12	43	35					0.05
B3.11	57 201 05 11 001	11 ~ 13	48	40					0.055
B3.12	57 201 05 12 001	12 ~ 14	48	42					0.06
B3.14	57 201 05 14 001	14 ~ 16	52	50	-	TPGX 0902..	CS 250 T	TORX T08	0.07
B3.16	57 201 05 16 001	16 ~ 18	58						
B3.18	57 201 05 18 001	18 ~ 22	63						0.1
B3.22	57 201 05 22 001	22 ~ 30	68						

B5.06	57 201 05 06 105	6 ~ 8	36		WCGT 0201..	-	TS 21	TORX T06	0.075
B5.08	57 201 05 08 105	8 ~ 10	48				TS 211		0.09
B5.10	57 201 05 10 105	10 ~ 12	60						0.1
B5.12	57 201 05 12 105	12 ~ 14	72						0.2
B5.14	57 201 05 14 105	14 ~ 16	84		-	TPGX 0902..	CS 250 T	TORX T08	0.3
B5.16	57 201 05 16 105	16 ~ 18	96						

B8.06	57 201 05 06 108	6 ~ 8	45		WCGT 0201..	-	TS 21	TORX T06	0.065
B8.08	57 201 05 08 108	8 ~ 10	60				TS 211		0.08
B8.10	57 201 05 10 108	10 ~ 12	75						0.1
B8.12	57 201 05 12 108	12 ~ 14	90						0.2
B8.14	57 201 05 14 108	14 ~ 16	105		-	TPGX 0902..	CS 250 T	TORX T08	0.2
B8.16	57 201 05 16 108	16 ~ 18	120						0.3

D'ANDREA

D'ANDREA MODULHARD'ANDREA

TRM 50/63 TRM 63/63 Ø 77 ~ 127

- TOOLHOLDERS FOR TESTAROSSA
- GRUNDHALTER FÜR TESTAROSSA
- PORTAHERRAMIENTAS PARA TESTAROSSA
- PORTE-OUTILS POUR TESTAROSSA
- PORTAUTENSILI PER TESTAROSSA

PS

Ø 77 ~ 125

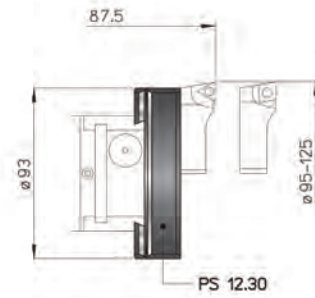
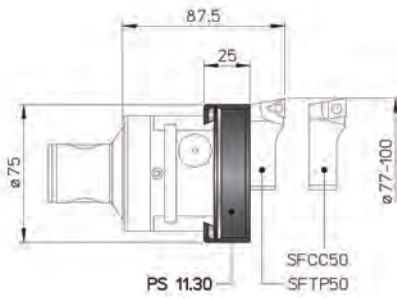

PS

Ø 82 ~ 127

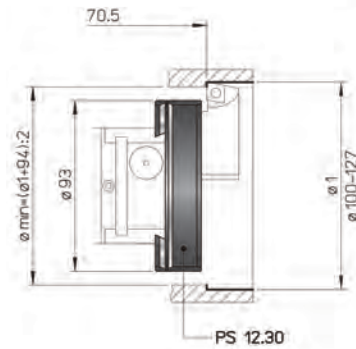
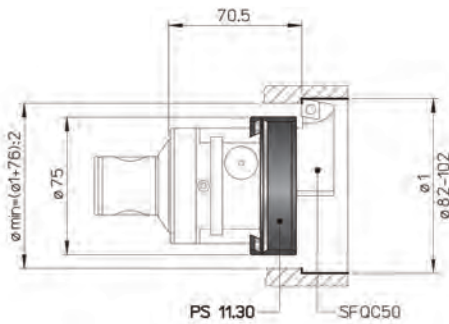

PS

Ø 77 ~ 125

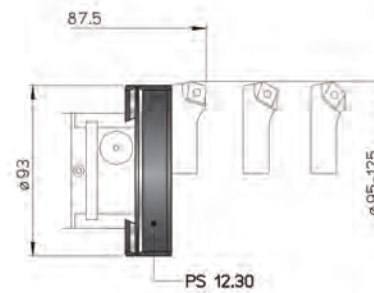
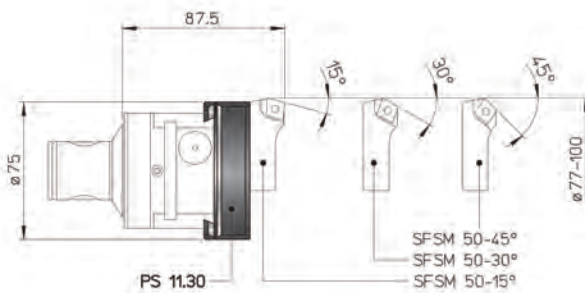

REF.	CODE	Kg.
PS 11.30	43 30 30 26 075 0	0.4
PS 12.30	43 30 30 26 095 0	0.5



TRM 50/63
TRM 63/63 Ø 5 ~ 77

testarossa d'andrea

- TOOLHOLDERS FOR TESTAROSSA
- GRUNDHALTER FÜR TESTAROSSA
- PORTAHERRAMIENTAS PARA TESTAROSSA
- PORTE-OUTILS POUR TESTAROSSA
- PORTAUTENSILI PER TESTAROSSA

P
Ø 30 ~ 77

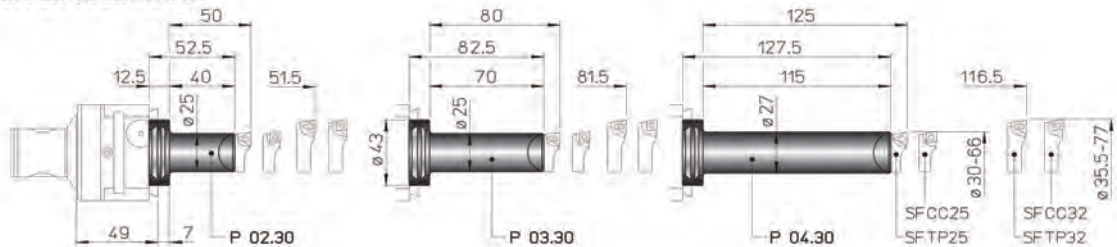

REF.	CODE	Kg.
P02.30	43 10 30 25 040 0	0.3
P03.30	43 10 30 25 070 0	0.4
P04.30	43 10 30 25 115 0	0.7

- TESTAROSSA EXTERNAL TURNING
- TESTAROSSA AUSSENDREHEN
- TESTAROSSA TORNEADO EXTERIOR
- TESTAROSSA TOURNAGE EXTÉRIEUR
- TESTAROSSA TORNITURA ESTERNA

PS + P25
Ø 5 ~ 35

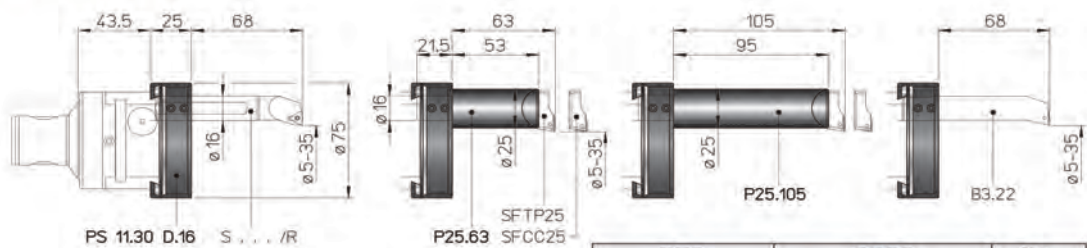

REF.	CODE	Kg.
PS 11.30 D.16	43 30 30 26 075 5	0.4
P25.63	43 51 16 25 063 0	0.5
P25.105	43 51 16 25 105 0	0.8

- BIT-HOLDERS FOR TESTAROSSA
- PLATTENHALTER FÜR TESTAROSSA
- PORTA-PLAQUITAS PARA TESTAROSSA
- PORTE-PLAQUETTES POUR TESTAROSSA
- SEGGI PER TESTAROSSA

SF

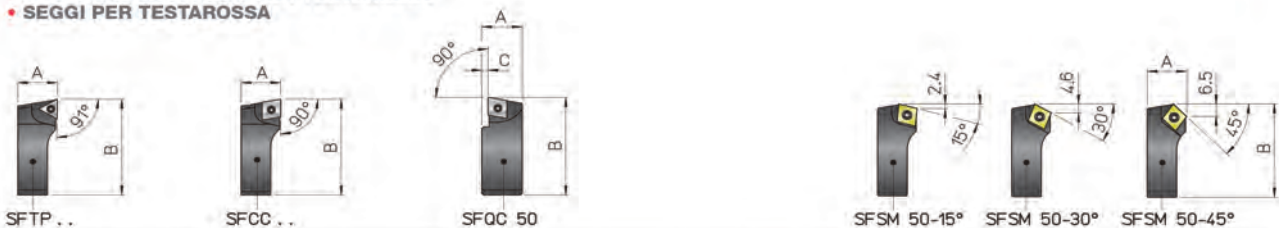

REF.	CODE	A	B	C	△	⊖	⊔	⊔	Kg.
SFTP 25	47 050 05 25 001	10	26.5	-	TPGX 0902..	-	CS 250T	TORX T08	0.01
SFTP 32	47 050 05 32 001	11.5	34.5	-	-	-	TORX T08		0.02
SFTP 50	47 050 05 50 001	19	52	-	TPGX 1103..	-	CS 300890T		0.08
SFCC 25	47 050 05 25 002	10	26.5	-	-	CCGT 0602..	TS 25	TORX T08	0.01
SFCC 32	47 050 05 32 002	11.5	34.5	-	-	CCGT 09T3..	TS 4	TORX T15	0.02
SFCC 50	47 050 05 50 002	19	52	-	-	CCGT 09T3..	TS 4	TORX T15	0.08
SFQC 50	47 050 05 50 062	20.5	53	3	-	CCMT 09T3..	TS 4	TORXT15	0.1
SFSM 50-15°	47 050 05 50 011	19	50.5	-	-	CCMT 09T3..	TS 4	TORXT15	0.07
SFSM 50-30°	47 050 05 50 013								
SFSM 50-45°	47 050 05 50 015								

D'ANDREA MODULHARD'ANDREA

TRM 50/80
TRM 80/80 Ø 2.5 ~ 160

• TESTAROSSA



2 µm

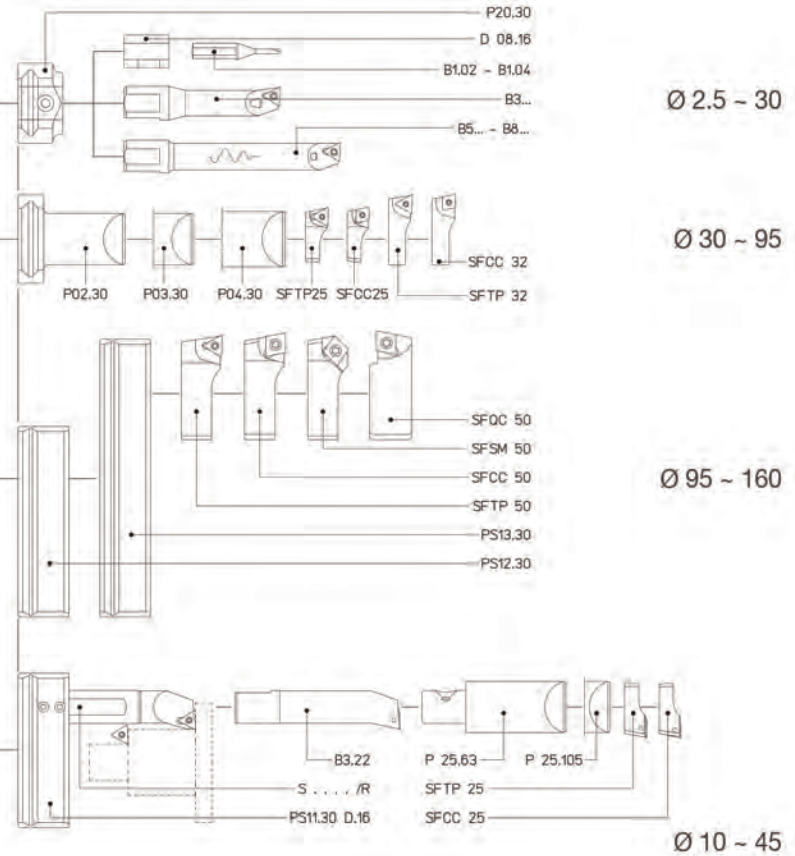
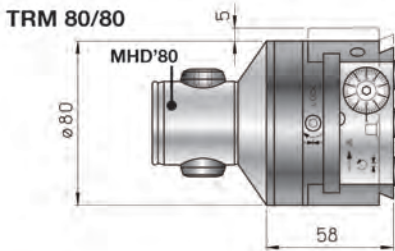
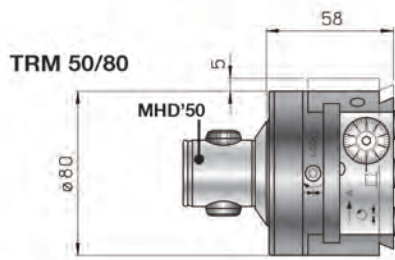

Ø 2.5 - 30

Ø 30 - 95

Ø 95 - 160

Ø 10 - 45

REF.	CODE	Kg.
TRM 50/80	45 50 050 0080 0	2
TRM 80/80	45 50 080 0080 0	2.5

KIT K01
Ø 6 - 220

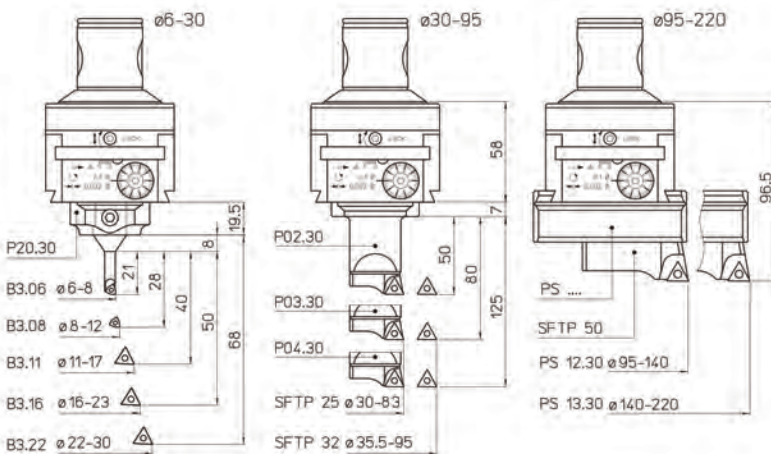

K01 TRM 50/80 - 80/80			
1 TRM./ 80			
1 P20.30	1 P02.30	1 SFTP25	1 B3.06
1 PS12.30	1 P03.30	1 SFTP32	1 B3.08
1 PS13.30	1 P04.30	1 SFTP50	1 B3.12
5 TPGX 090202L DC100			1 B3.16
1 TPGX 110302L DC100			1 B3.22
2 WCGT 020102L DC100			

REF.	CODE	Ø
K01 TRM 50/80	65 50 050 1080 1	6 - 220
K01 TRM 80/80	65 50 080 1080 1	



TRM 50/80
TRM 80/80 Ø 2.5 ~ 30

testarossadandrea

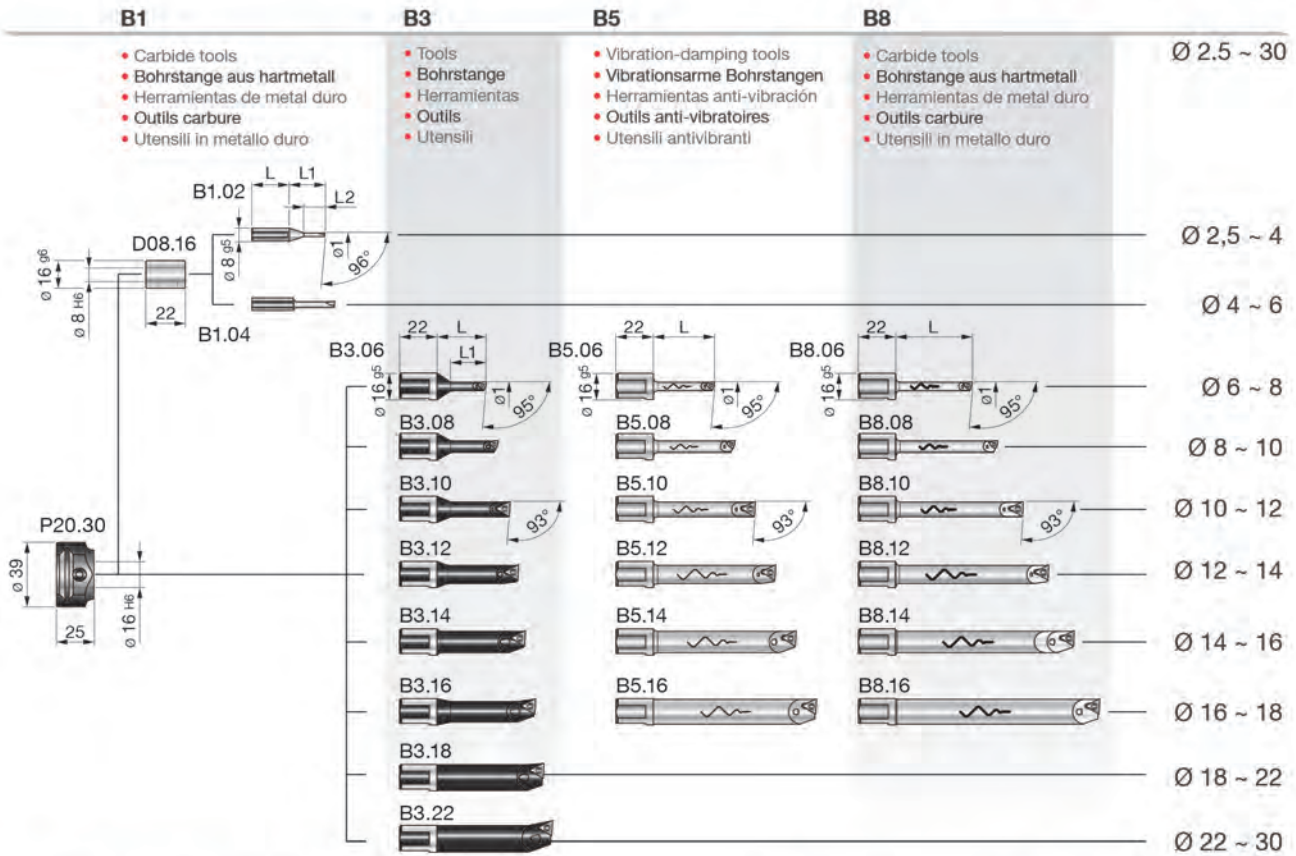

REF.	CODE	Kg.
D08.16	20 056 01 16 08 2	0.02

REF.	CODE	Kg.
P20.30	43 10 30 16 030 0	0.2

REF.	CODE	Ø1	L	L1	L2	Kg.
B1.02	57 201 05 02 001	2.5 ~ 4	22	21	12.5	0.02
B1.04	57 201 05 04 001	4 ~ 6	24	24	-	

REF.	CODE	Ø1	L	L1	⊖	⚠	⌢	⌘	Kg.
B3.06	57 201 05 06 001	6 ~ 8	29	21	WCGT 0201..	-	TS 21	TORX T06	0.035
B3.08	57 201 05 08 001	8 ~ 10	36	28					TS 211
B3.10	57 201 05 10 001	10 ~ 12	43	35	-	TPGX 0902..	CS 250 T	TORX T08	0.05
B3.11	57 201 05 11 001	11 ~ 13	48	40					0.055
B3.12	57 201 05 12 001	12 ~ 14	48	42					0.06
B3.14	57 201 05 14 001	14 ~ 16	52	50					0.07
B3.16	57 201 05 16 001	16 ~ 18	58	-					0.1
B3.18	57 201 05 18 001	18 ~ 22	63	-					
B3.22	57 201 05 22 001	22 ~ 30	68	-					

B5.06	57 201 05 06 105	6 ~ 8	36	-	WCGT 0201..	-	TS 21	TORX T06	0.075
B5.08	57 201 05 08 105	8 ~ 10	48						TS 211
B5.10	57 201 05 10 105	10 ~ 12	60		-	TPGX 0902..	CS 250 T	TORX T08	0.1
B5.12	57 201 05 12 105	12 ~ 14	72						0.2
B5.14	57 201 05 14 105	14 ~ 16	84						0.3
B5.16	57 201 05 16 105	16 ~ 18	96						

B8.06	57 201 05 06 108	6 ~ 8	45	-	WCGT 0201..	-	TS 21	TORX T06	0.065
B8.08	57 201 05 08 108	8 ~ 10	60						TS 211
B8.10	57 201 05 10 108	10 ~ 12	75		-	TPGX 0902..	CS 250 T	TORX T08	0.1
B8.12	57 201 05 12 108	12 ~ 14	90						0.2
B8.14	57 201 05 14 108	14 ~ 16	105						0.3
B8.16	57 201 05 16 108	16 ~ 18	120						

D'ANDREA

D'ANDREA MODULHARD'ANDREA

TRM 50/80 TRM 80/80 Ø 95 ~ 162

- TOOLHOLDERS FOR TESTAROSSA
- GRUNDHALTER FÜR TESTAROSSA
- PORTAHERRAMIENTAS PARA TESTAROSSA
- PORTE-OUTILS POUR TESTAROSSA
- PORTAUTENSILI PER TESTAROSSA

PS

Ø 95 ~ 160

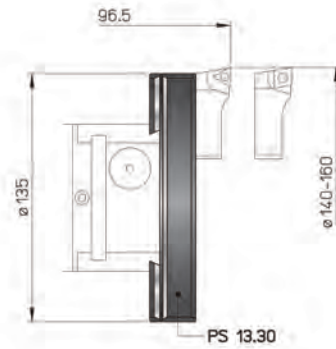
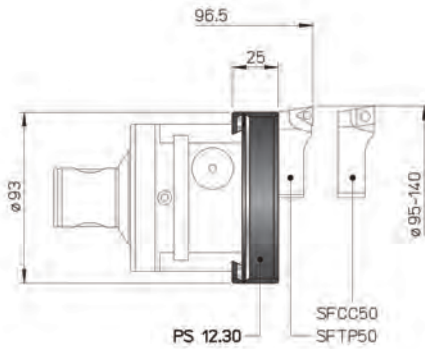

PS

Ø 100 ~ 162

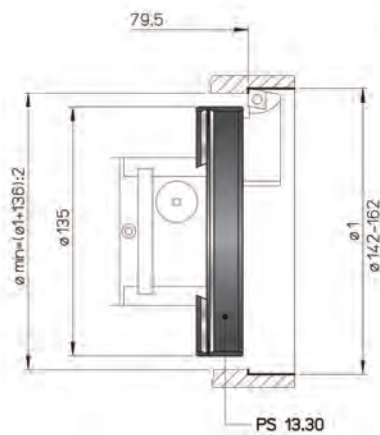
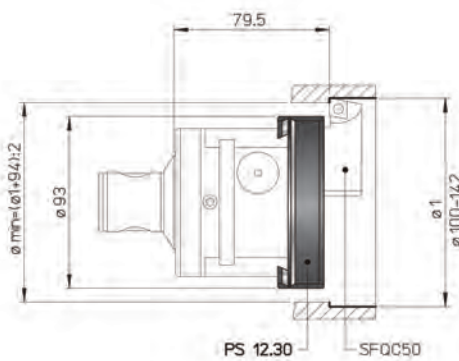

PS

Ø 95 ~ 160

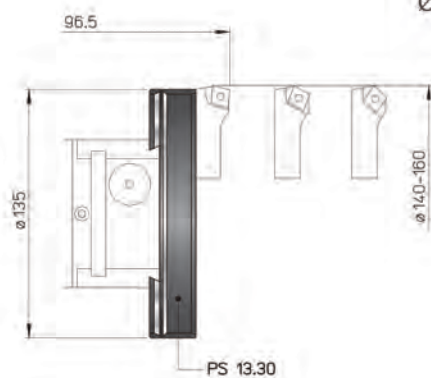
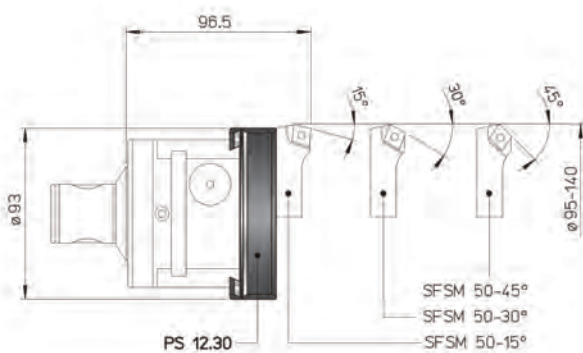

REF.	CODE	Kg.
PS 12.30	43 30 30 26 095 0	0.5
PS 13.30	43 30 30 26 140 0	0.7



TRM 50/80 TRM 80/80 Ø 10 ~ 95

testarossa d'andrea

- TOOLHOLDERS FOR TESTAROSSA
- WERKZEUGE FÜR TESTAROSSA
- PORTAHERRAMIENTAS PARA TESTAROSSA
- PORTE-OUTILS POUR TESTAROSSA
- PORTAUTENSILI PER TESTAROSSA

P
Ø 30 ~ 95

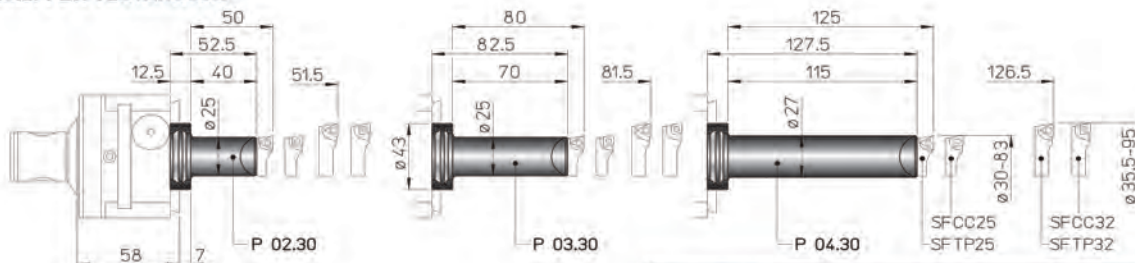

REF.	CODE	Kg.
P02.30	43 10 30 25 040 0	0.3
P03.30	43 10 30 25 070 0	0.4
P04.30	43 10 30 25 115 0	0.7

- TESTAROSSA EXTERNAL TURNING
- TESTAROSSA AUSSENDREHEN
- TESTAROSSA TORNEADO EXTERIOR
- TESTAROSSA TOURNAGE EXTÉRIEUR
- TESTAROSSA TORNITURA ESTERNA

PS + P25
Ø 10 ~ 45

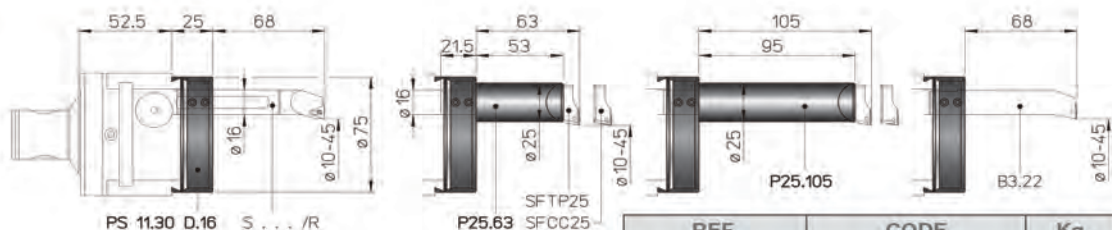

REF.	CODE	Kg.
PS 11.30 D.16	43 30 30 26 075 5	0.4
P25.63	43 51 16 25 063 0	0.5
P25.105	43 51 16 25 105 0	0.8

- BIT-HOLDERS FOR TESTAROSSA
- PLATTENHALTER FÜR TESTAROSSA
- PORTA-PLAQUITAS PARA TESTAROSSA
- PORTE-PLAQUETTES POUR TESTAROSSA
- SEGGI PER TESTAROSSA

SF



REF.	CODE	A	B	C	△	□	U	⊥	Kg.
SFTP 25	47 050 05 25 001	10	26.5	-	TPGX 0902..	-	CS 250T	TORX T08	0.01
SFTP 32	47 050 05 32 001	11.5	34.5	-	TPGX 1103..	-	CS 300890T	TORX T08	0.02
SFTP 50	47 050 05 50 001	19	52	-	TPGX 1103..	-	CS 300890T	TORX T08	0.08
SFCC 25	47 050 05 25 002	10	26.5	-	-	CCGT 0602..	TS 25	TORX T08	0.01
SFCC 32	47 050 05 32 002	11.5	34.5	-	-	CCGT 09T3..	TS 4	TORX T15	0.02
SFCC 50	47 050 05 50 002	19	52	-	-	CCGT 09T3..	TS 4	TORX T15	0.08
SFQC 50	47 050 05 50 062	20.5	53	3	-	CCMT 09T3..	TS 4	TORXT15	0.1
SFSM 50-15°	47 050 05 50 011	19	50.5	-	-	CCMT 09T3..	TS 4	TORXT15	0.07
SFSM 50-30°	47 050 05 50 013								
SFSM 50-45°	47 050 05 50 015								

D'ANDREA

D'ANDREA MODULHARD'ANDREA

TRM 80/125 Ø 36 ~ 500

• TESTAROSSA

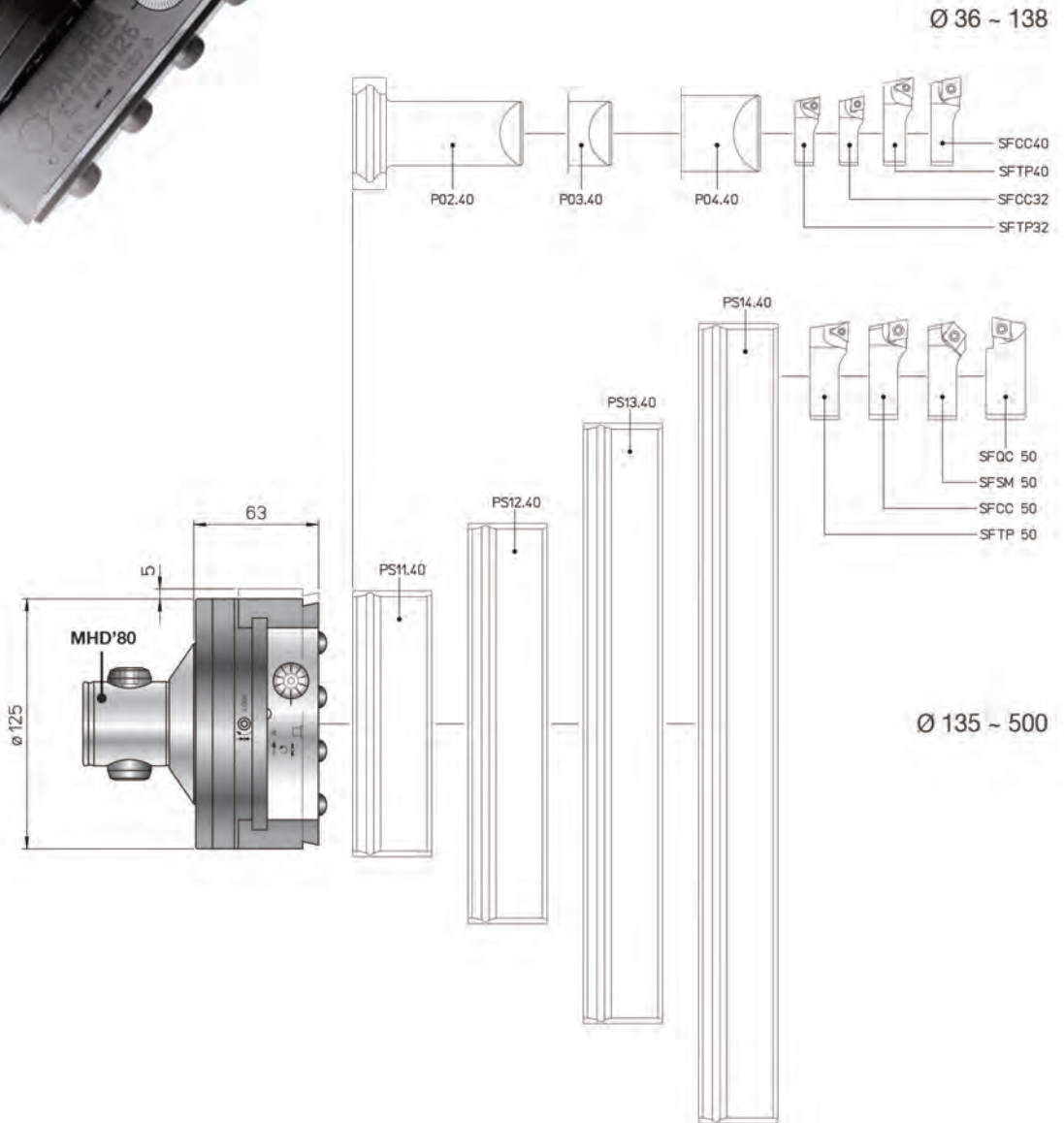

REF.	CODE	Kg.
TRM 80/125	45 50 080 0125 0	5.5

D'ANDREA



TRM 80/125 Ø 36 ~ 410

testarossadandrea

KIT K03
Ø 36 ~ 410

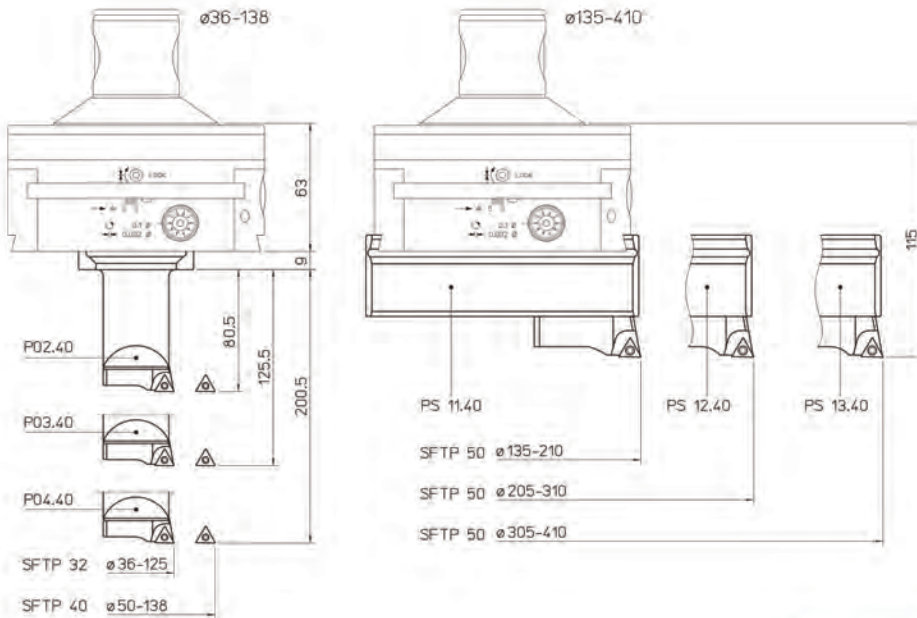

K03 TRM 80/125		
1 P02.40	1 PS11.40	
1 P03.40	1 PS12.40	1 SFTP50
1 P04.40	1 PS13.40	

REF.	CODE	Ø
K03 TRM 80/125	65 50 125 0003 0	36 ~ 410

P
Ø 36 ~ 138

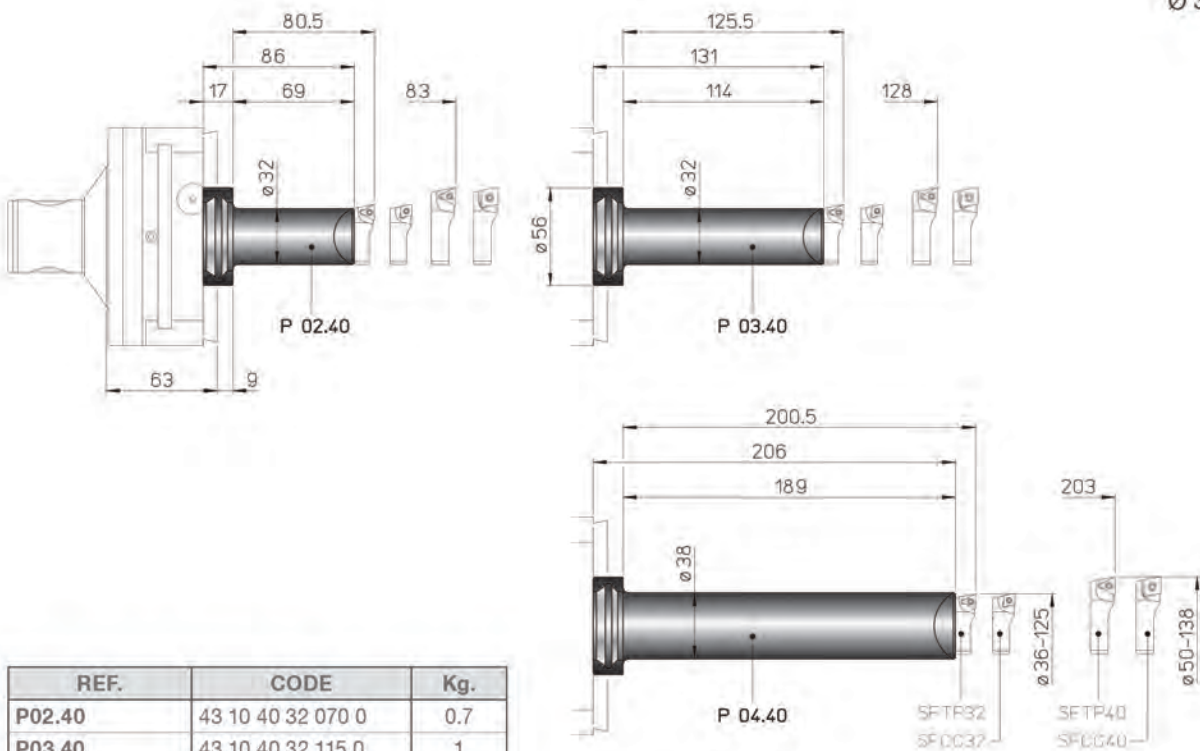

REF.	CODE	Kg.
P02.40	43 10 40 32 070 0	0.7
P03.40	43 10 40 32 115 0	1
P04.40	43 10 40 32 190 0	2

D'ANDREA

TRM 80/125 Ø 135 ~ 502

- TOOLHOLDERS FOR TESTAROSSA
- GRUNDHALTER FÜR TESTAROSSA
- PORTAHERRAMIENTAS PARA TESTAROSSA
- PORTE-OUTILS POUR TESTAROSSA
- PORTAUTENSILI PER TESTAROSSA

PS

Ø 135 ~ 502

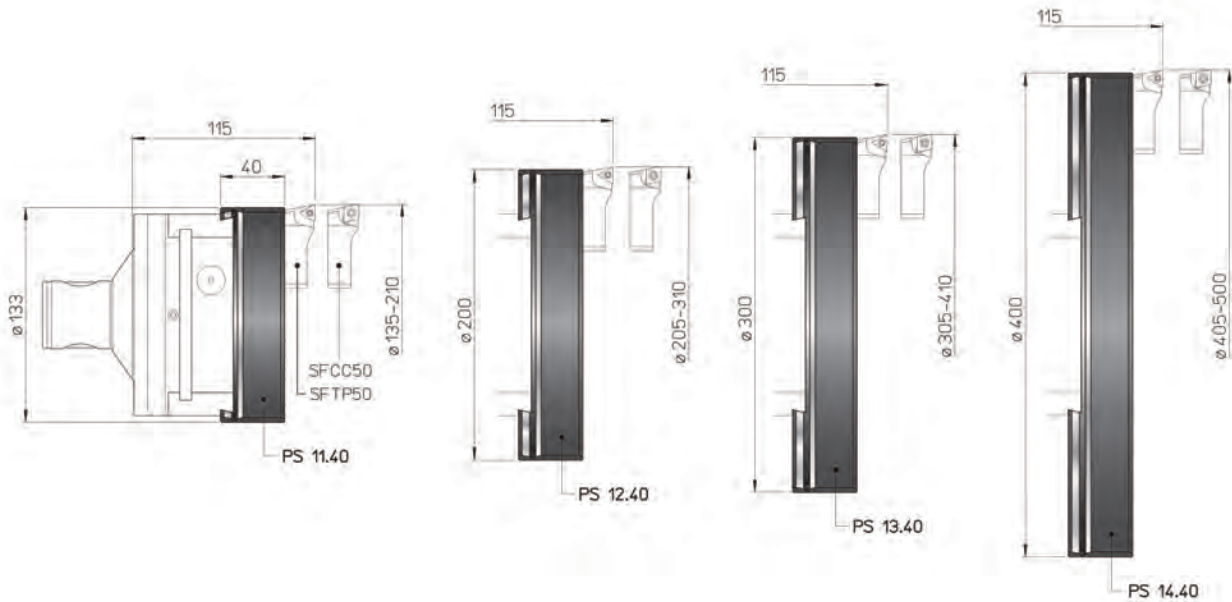

PS

Ø 140 ~ 502

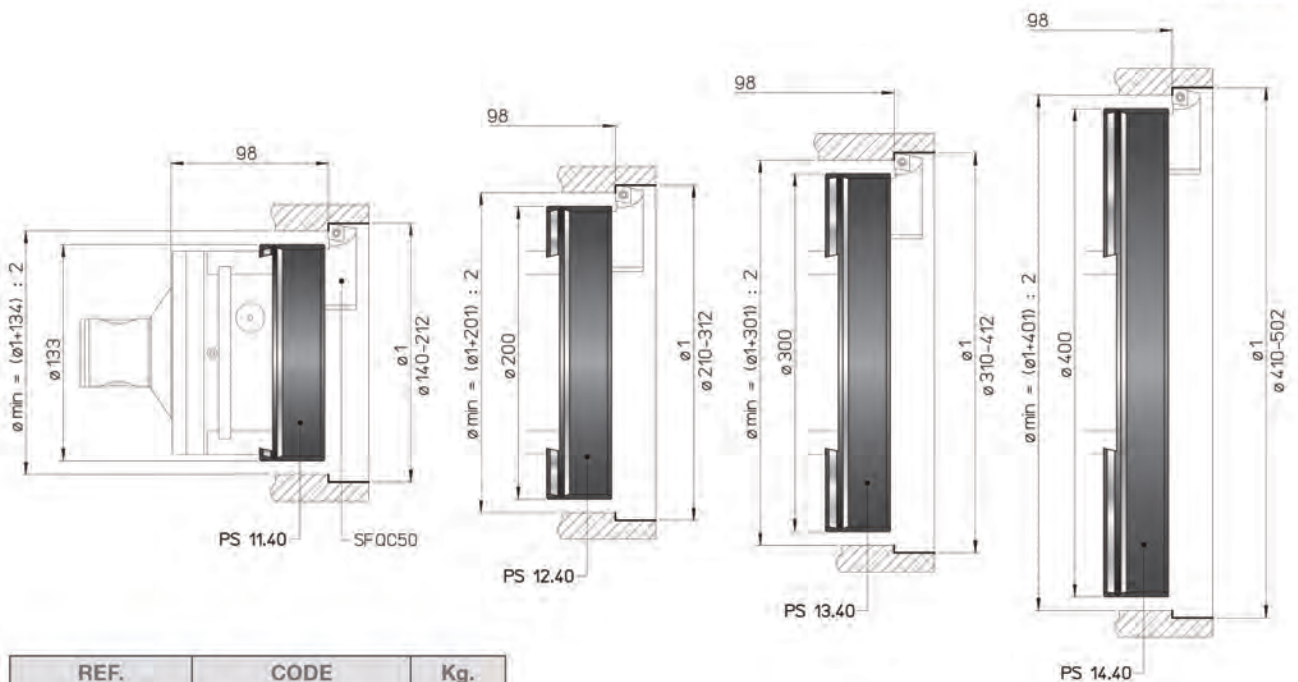

REF.	CODE	Kg.
PS 11.40	43 30 40 35 150 0	1.5
PS 12.40	43 30 40 35 230 0	2.4
PS 13.40	43 30 40 35 330 0	3.5
PS 14.40	43 30 40 35 400 0	4.6



- TOOLHOLDERS FOR TESTAROSSA
- GRUNDHALTER FÜR TESTAROSSA
- PORTAHERRAMIENTAS PARA TESTAROSSA
- PORTE-OUTILS POUR TESTAROSSA
- PORTAUTENSILI PER TESTAROSSA

PS
Ø 135 ~ 500

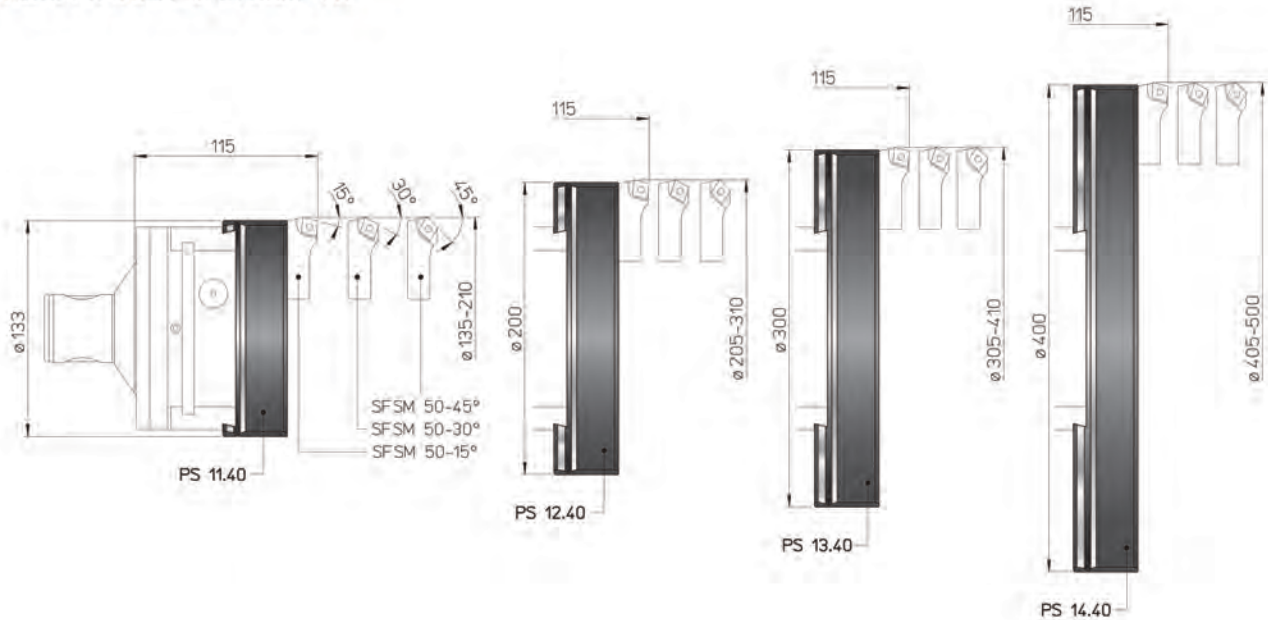

- BIT-HOLDERS FOR TESTAROSSA
- PLATTENHALTER FÜR TESTAROSSA
- PORTA-PLAQUITAS PARA TESTAROSSA
- PORTE-PLAQUETTES POUR TESTAROSSA
- SEGGI PER TESTAROSSA

SF

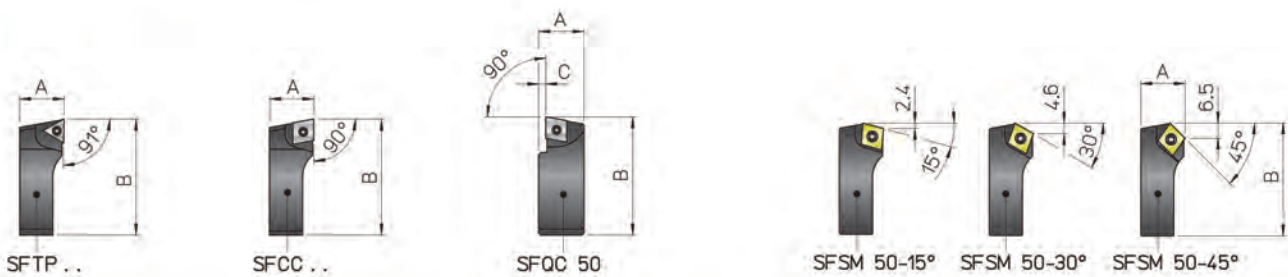

REF.	CODE	A	B	C	△	⊖	⌢	⌘	Kg.
SFTP 32	47 050 05 32 001	11.5	34.5	-	TPGX 0902..	-	CS 250T	TORX T08	0.02
SFTP 40	47 050 05 40 001	14	44	-	TPGX 1103..	-	CS 300890T		0.04
SFTP 50	47 050 05 50 001	19	52	-	-	-	-		0.08
SFCC 32	47 050 05 32 002	11.5	34.5	-	-	CCGT 0602..	TS 25	TORX T08	0.02
SFCC 40	47 050 05 40 002	14	44	-	-	CCGT 09T3..	TS 4	TORX T15	0.04
SFCC 50	47 050 05 50 002	19	52	-	-	-	-	-	0.08
SFQC 50	47 050 05 50 062	20.5	53	3	-	CCMT 09T3..	TS 4	TORXT15	0.1
SF5M 50-15°	47 050 05 50 011	19	50.5	-	-	CCMT 09T3..	TS 4	TORXT15	0.07
SF5M 50-30°	47 050 05 50 013								
SF5M 50-45°	47 050 05 50 015								

TR-ELETTRA 50 MHD'50
Ø 2.5 ~ 110

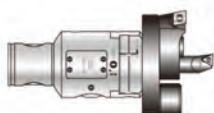

TR-ELETTRA 63 MHD'63
Ø 6 ~ 125

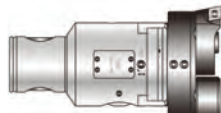

TR-ELETTRA 80 - MHD'80
Ø 6 ~ 200

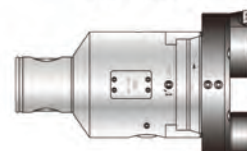

2 μ m



TR-ELETTRA 50 \varnothing 2.5 ~ 110 MHD'50

testarossa d'andrea



2 μ m

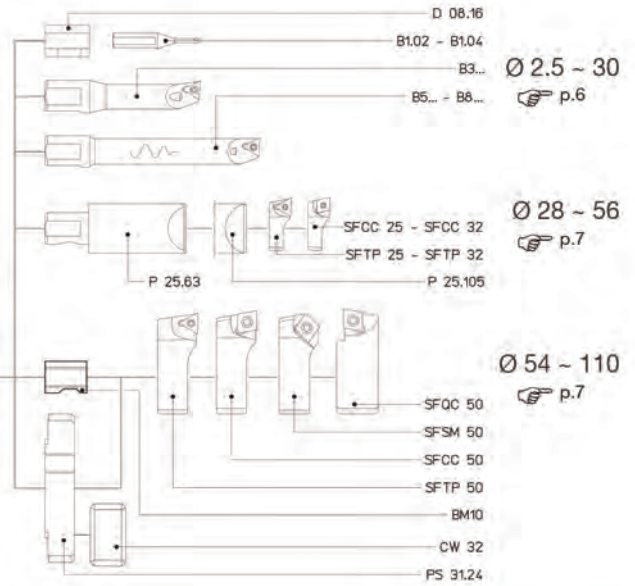
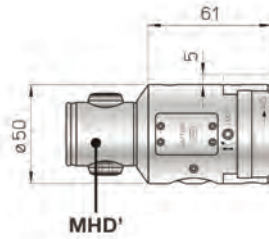

MHD'	REF.	CODE	Kg.
50	TR-ELETTRA 50 MHD'50	455200500500	1.1

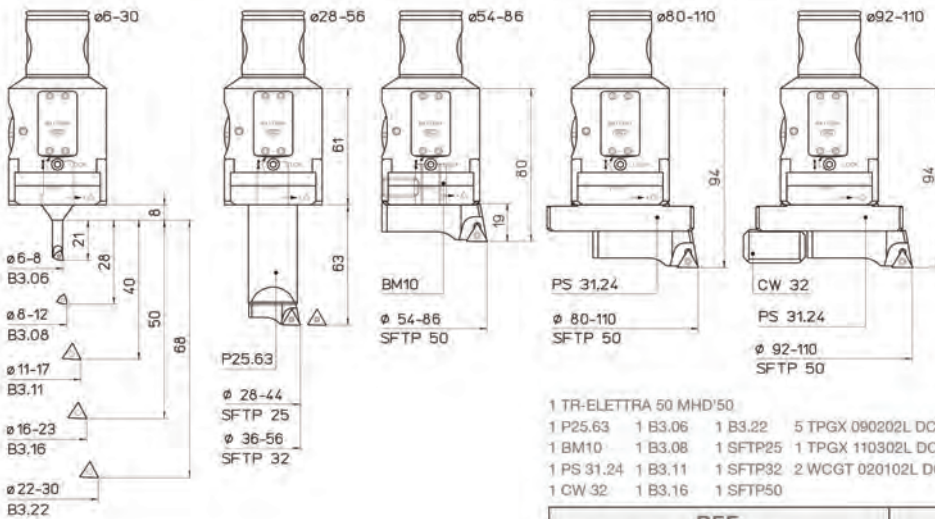

KIT K01
 \varnothing 6 ~ 110



- 1 TR-ELETTRA 50 MHD'50
 1 P25.63 1 B3.06 1 B3.22 5 TPGX 090202L DC100
 1 BM10 1 B3.08 1 SFTP25 1 TPGX 110302L DC100
 1 PS 31.24 1 B3.11 1 SFTP32 2 WCGT 020102L DC100
 1 CW 32 1 B3.16 1 SFTP50

REF.	CODE	\varnothing
K01 TR-ELETTRA 50 MHD'50	655200500500	6 ~ 110

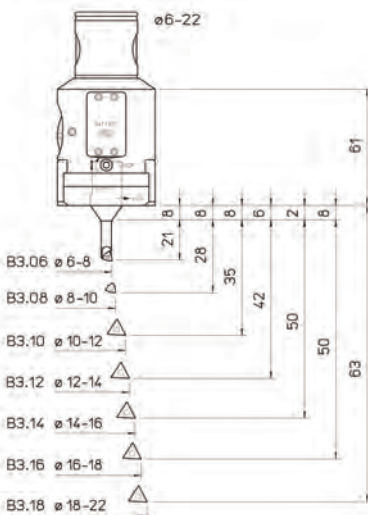

KIT K00
 \varnothing 6 ~ 22



- 1 TR-ELETTRA 50 MHD'50
 1 B3.06 1 B3.12 1 B3.18
 1 B3.08 1 B3.14 5 TPGX 090202L DC100
 1 B3.10 1 B3.16 2 WCGT 020102L DC100

REF.	CODE	\varnothing
K00 TR-ELETTRA 50 MHD'50	655200500501	6 ~ 22

D'ANDREA

D'ANDREA

MODULHARD'ANDREA

ALUMINIUM TOOLS LINE

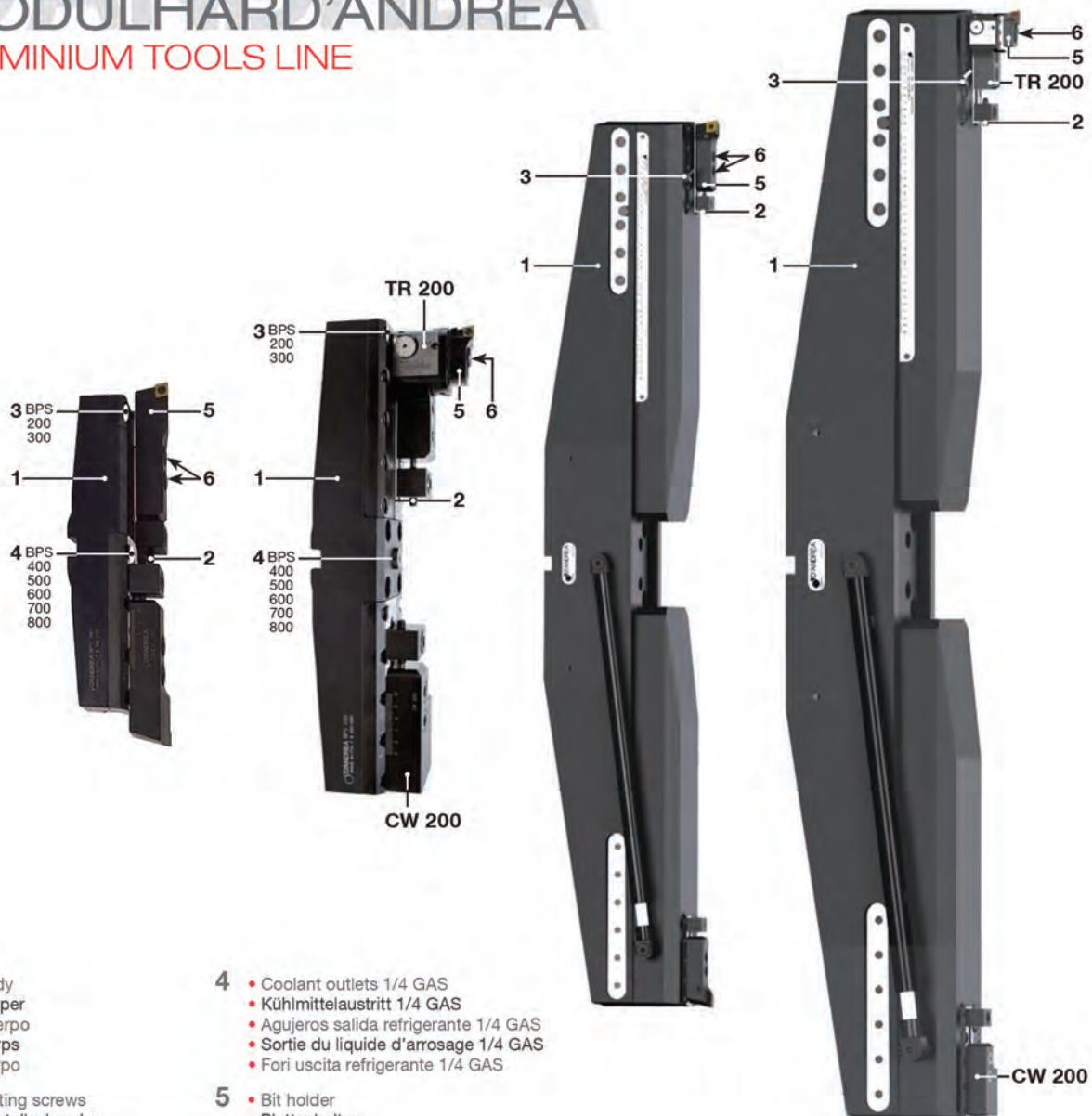

- | | |
|--|--|
| <p>1</p> <ul style="list-style-type: none"> • Body • Körper • Cuerpo • Corps • Corpo <p>2</p> <ul style="list-style-type: none"> • Setting screws • Einstellschraube • Tornillo de regulación • Vis de réglage • Vite di regolazione <p>3</p> <ul style="list-style-type: none"> • Coolant outlets • Kühlmittelaustritt • Agujeros salida refrigerante • Sortie du liquide d'arrosage • Fori uscita refrigerante | <p>4</p> <ul style="list-style-type: none"> • Coolant outlets 1/4 GAS • Kühlmittelaustritt 1/4 GAS • Agujeros salida refrigerante 1/4 GAS • Sortie du liquide d'arrosage 1/4 GAS • Fori uscita refrigerante 1/4 GAS <p>5</p> <ul style="list-style-type: none"> • Bit holder • Plattenhalter • Portaplaquita • Porte-plaquettes • Seggio portainseriti <p>6</p> <ul style="list-style-type: none"> • Tools clamp screws • Werkzeugklemm-schrauben • Tornillos bloqueo herramienta • Vis blocage outil • Viti bloccaggio utensile |
|--|--|

MR BPS double bit 크로스바는 ϕ 200 ~ 2800mm의 작업을 할 수 있습니다. BPS는 알루미늄으로 만들었고, 스틸 double bit plate와 조립되어 조작되어 집니다.

GB The BPS double-bit crossbars cover a working area from ϕ 200 - 2800 mm. The BPS double-bit crossbars are constructed in Aluminium and mounted on a steel double-bit plate.

D Die Zweischnider BPS bedecken ein Arbeitsfeld von ϕ 200 - 2800 mm. Die Bohrschienen BPS bestehen aus Aluminium auf welches die Sitzhalterungsplatte aus Stahl befestigt wird.

E Las barras porta-asiento BPS cubren un campo de trabajo de 200 a 2800 mm de diámetro. Las barras porta-asiento BPS están realizadas en aluminio, sobre el cual se fija la placa porta-asiento de acero.

I Le barre portaseggio BPS coprono un campo di lavoro da ϕ 200 - 2800 mm. Le barre portaseggio BPS sono costruite in alluminio sul quale viene fissata la piastra portaseggio in acciaio.



BPS Ø 200 ~ 2800

- DOUBLE-BIT CROSSBARS FOR BIG DIAMETERS
- ZWEISCHNEIDERBOHRSCIENEN FÜR GROSSER DURCHMESSER
- BARRAS PORTA-ASIENTO DE DOS CORTES
- SEMELLES POUR A GRANDS DIAMÈTRES
- BARRE PORTASEGGIO PER GRANDI DIAMETRI

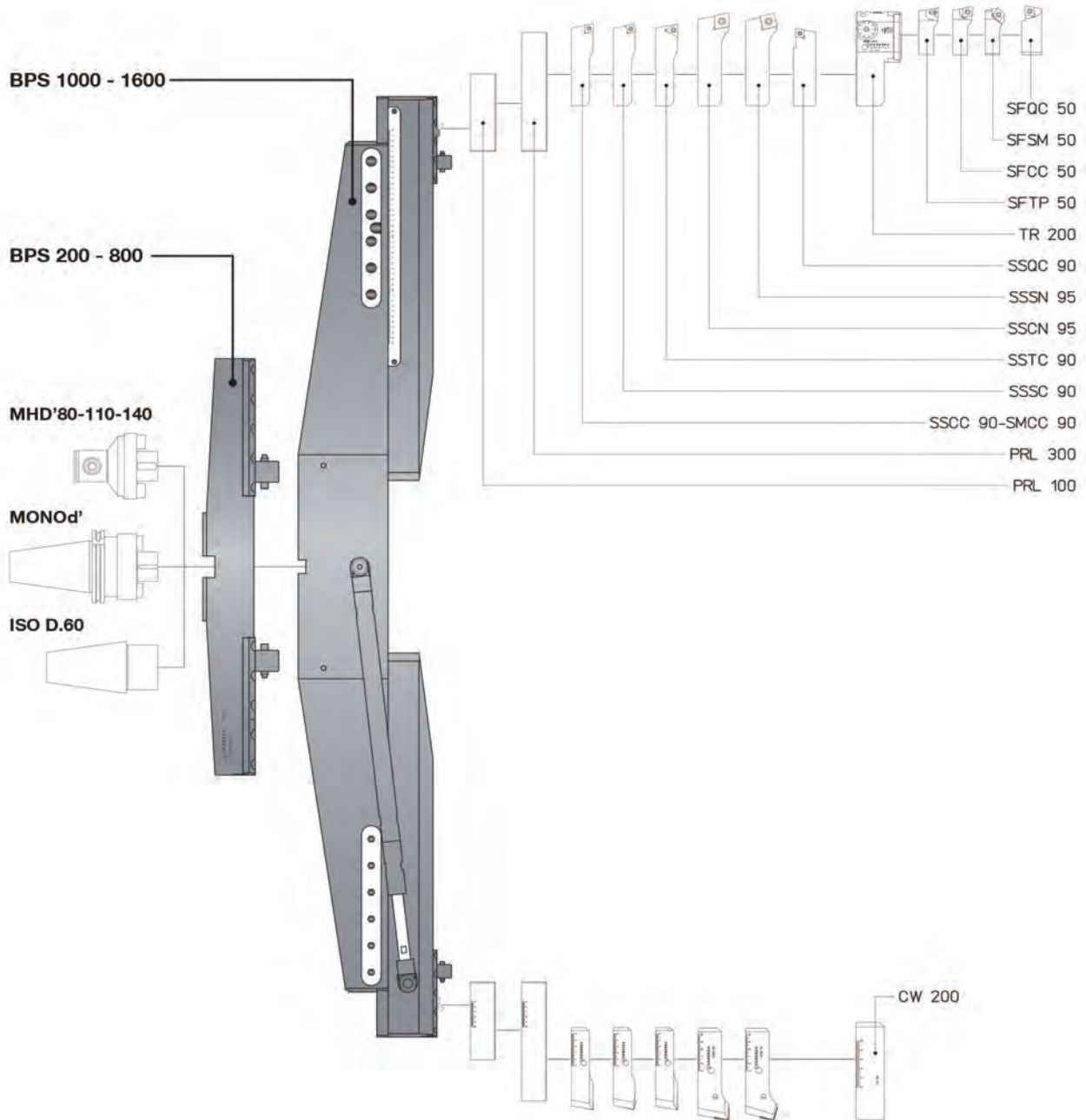

REF.	CODE	Kg.
BPS 200	43 55 40 88 198 0	3.2
BPS 300	43 55 40 88 298 0	3.9
BPS 400	43 55 40 88 398 0	6.9
BPS 500	43 55 60 88 494 0	9.4
BPS 600	43 55 60 88 594 0	9.9

REF.	CODE	Kg.
BPS 700	43 55 60 88 694 0	11.2
BPS 800	43 55 60 88 794 0	15.2
BPS 1000	43 55 60 90 1000	70
BPS 1160	43 55 60 90 1160	100
BPS 1600	43 55 60 90 1600	150

D'ANDREA

MODULHARD'ANDREA

ALUMINIUM TOOLS LINE

BPS 200~800 Ø 200 ~ 1200

- DOUBLE-BIT BORING CROSSBARS
- ZWEISCHNEIDER-BOHRSCIENEN
- BARRAS PORTA-ASIENTO DE DOS CORTES
- LES SEMELLES PORTE-LOGEMENT À DEUX TRANCHANTS
- BARRE PORTASEGGIO BITAGLIANTI

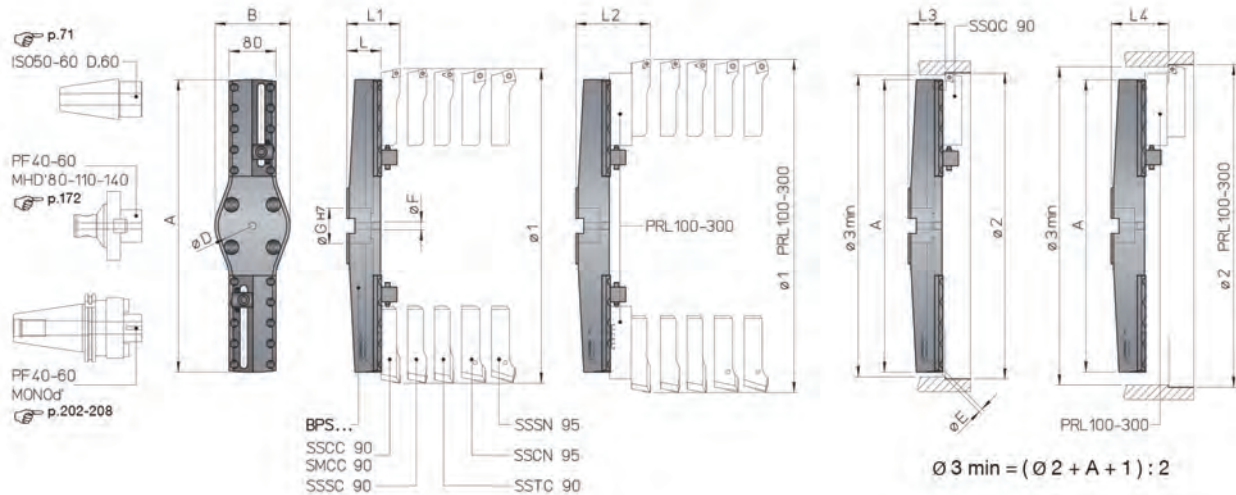

	BPS 200	BPS 300	BPS 400	BPS 500	BPS 600	BPS 700	BPS 800
A	194	288	394	494	594	694	794
B	-			128			
Ø D	(4xM12) 66.7			(4xM16) 101.6			
Ø E	2.5		-				
Ø F	-		1/4 GAS				
Ø G	40			60			
Ø 1	200 ~ 300	300 ~ 400	400 ~ 500	500 ~ 600	600 ~ 700	700 ~ 800	800 ~ 900
Ø 1 PRL 100	300 ~ 400	400 ~ 500	500 ~ 600	600 ~ 700	700 ~ 800	800 ~ 900	900 ~ 1000
Ø 1 PRL 300	400 ~ 600	500 ~ 700	600 ~ 800	700 ~ 900	800 ~ 1000	900 ~ 1100	1000 ~ 1200
Ø 2	202 ~ 302	302 ~ 402	402 ~ 502	502 ~ 602	602 ~ 702	702 ~ 802	802 ~ 902
Ø 2 PRL 100	302 ~ 402	402 ~ 502	502 ~ 602	602 ~ 702	702 ~ 802	802 ~ 902	902 ~ 1002
Ø 2 PRL 300	402 ~ 602	502 ~ 702	602 ~ 802	702 ~ 902	802 ~ 1002	902 ~ 1102	1002 ~ 1202
L	54		61	69	71	74	80
L1 S...90	86		93	101	103	106	112
L1 S...95	94		101	109	111	114	120
L2 PRL 100 S...90	116		123	131	133	136	142
L2 PRL 300 S...90	126		133	141	143	146	152
L2 PRL 100 S...95	124		131	139	141	144	150
L2 PRL 300 S...95	134		141	149	151	154	160
L3 SSQC 90	56.5		63.5	71.5	73.5	76.5	82.5
L4 PRL 100 SSQC 90	86.5		93.5	101.5	103.5	106.5	112.5
L4 PRL 300 SSQC 90	96.5		103.5	111.5	113.5	116.5	122.5



BPS 200~800 Ø 200 ~ 1200

- DOUBLE-BIT CROSSBARS FOR BIG DIAMETER FINISH
- ZWISCHNEIDER-BOHRSCHEIENEN FÜR FEINBEARBEITUNGEN GROSSER DURCHMESSER
- BARRAS PORTA-ASIENTO DE DOS CORTES
- LES SEMELLES PORTE-LOGEMENT POUR FINISSAGE DES GRANDS DIAMÈTRES
- BARRE PORTASEGGIO PER FINITURA GRANDI DIAMETRI

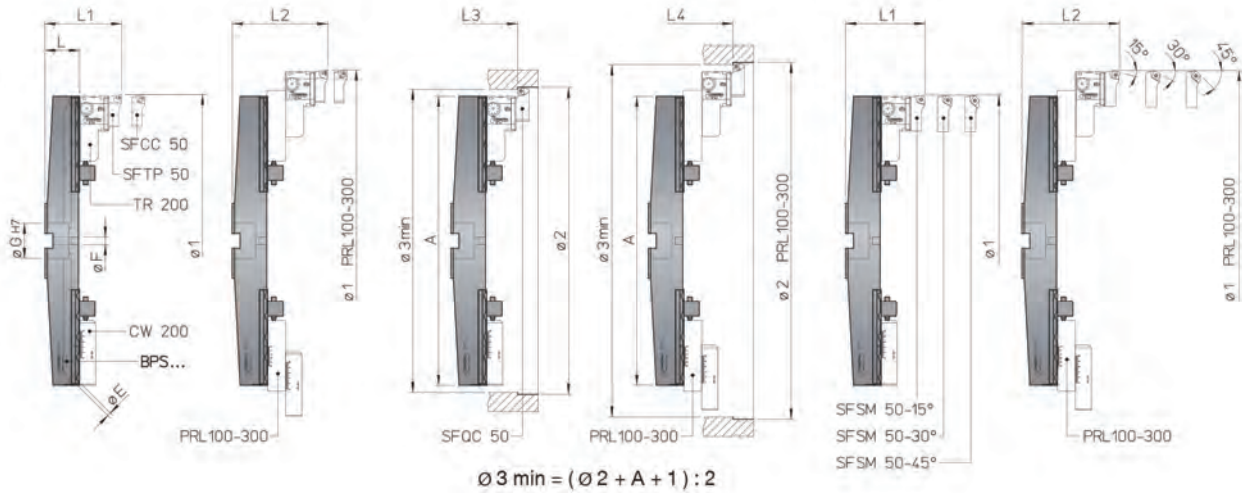

	BPS 200	BPS 300	BPS 400	BPS 500	BPS 600	BPS 700	BPS 800
A	194	288	394	494	594	694	794
B	-			128			
Ø D	(4xM12) 66.7			(4xM16) 101.6			
Ø E	2.5		-				
Ø F	-		1/4 GAS				
Ø G	40			60			
Ø 1	200 - 300	300 - 400	400 - 500	500 - 600	600 - 700	700 - 800	800 - 900
Ø 1 PRL 100	300 - 400	400 - 500	500 - 600	600 - 700	700 - 800	800 - 900	900 - 1000
Ø 1 PRL 300	400 - 600	500 - 700	600 - 800	700 - 900	800 - 1000	900 - 1100	1000 - 1200
Ø 2	202 - 302	302 - 402	402 - 502	502 - 602	602 - 702	702 - 802	802 - 902
Ø 2 PRL 100	302 - 402	402 - 502	502 - 602	602 - 702	702 - 802	802 - 902	902 - 1002
Ø 2 PRL 300	402 - 602	502 - 702	602 - 802	702 - 902	802 - 1002	902 - 1102	1002 - 1202
L	54		61	69	71	74	80
L1	120		127	135	137	140	146
L2 PRL 100	150		157	165	167	170	176
L2 PRL 300	160		167	175	177	180	186
L3	103		110	118	120	123	129
L4 PRL 100	133		140	148	150	153	159
L4 PRL 300	143		150	158	160	163	169

D'ANDREA

MODULHARD'ANDREA

ALUMINIUM TOOLS LINE

BPS 1000~1600

Ø 1000 ~ 2800

- DOUBLE-BIT BORING CROSSBARS
- ZWEISCHNEIDER-BOHRSCHIENEN
- BARRAS PORTA-ASIENTO DE DOS CORTES
- LES SEMELLES PORTE-LOGEMENT À DEUX TRANCHANTS
- BARRE PORTASEGGIO BITAGLIANTI

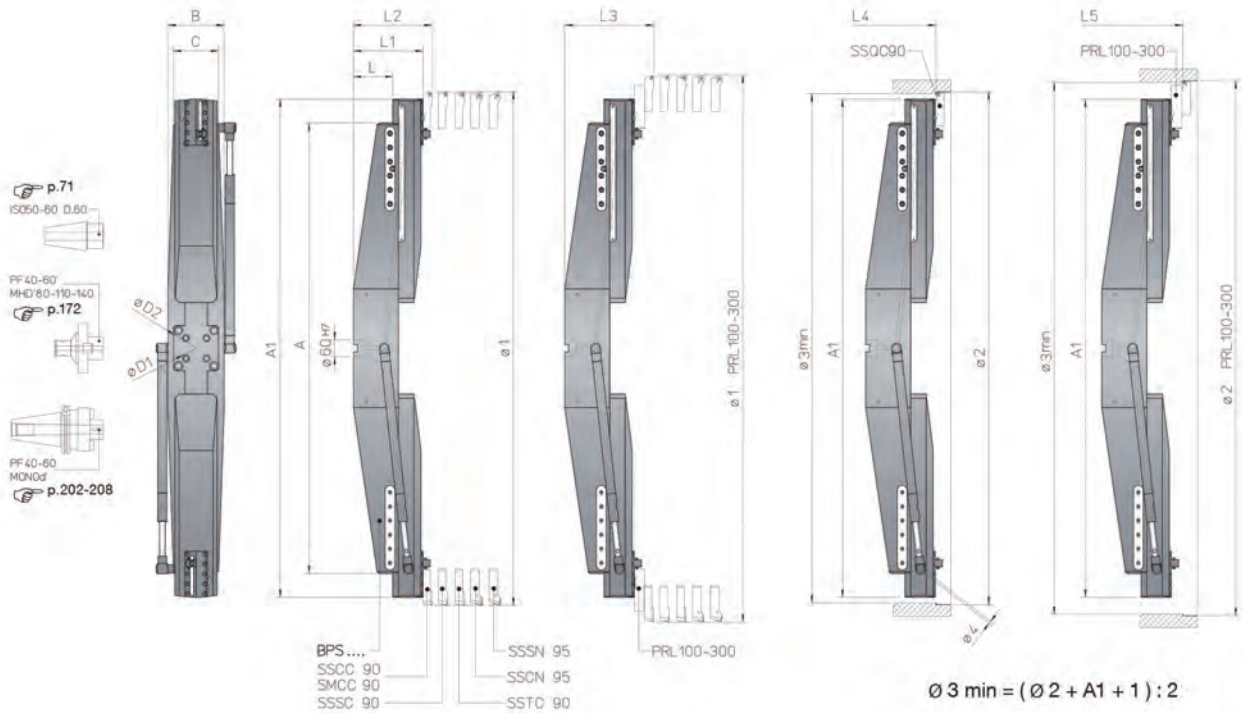

	BPS 1000	BPS 1160	BPS 1600
A	995		1595
A1	995 ~ 1495	1595 ~ 1895	1595 ~ 2395
B	160		200
C	150		160
Ø D1	(4xM16) 101.6		
Ø D2	-		(4xM20) 177.8
Ø 1	1000 ~ 1600	1600 ~ 2000	1600 ~ 2500
Ø 1 PRL 100	1100 ~ 1700	1700 ~ 2100	1700 ~ 2600
Ø 1 PRL 300	1200 ~ 1900	1800 ~ 2300	1800 ~ 2800
Ø 2	1002 ~ 1602	1602 ~ 2002	1602 ~ 2502
Ø 2 PRL 100	1102 ~ 1702	1702 ~ 2102	1702 ~ 2602
Ø 2 PRL 300	1202 ~ 1902	1802 ~ 2302	1802 ~ 2802
L	100		140
L1	191	206	246
L2 S... 90	223	238	278
L2 S... 95	231	246	286
L3 PRL 100 S... 90	253	268	308
L3 PRL 300 S... 90	263	278	318
L3 PRL 100 S... 95	261	276	316
L3 PRL 300 S... 95	271	286	326
L4 SSQC 90	193.5	208.5	248.5
L5 PRL 100 SSQC 90	223.5	238.5	278.5
L5 PRL 300 SSQC 90	233.5	248.5	288.5



BPS 1000~1600

Ø 1000 ~ 2800

- DOUBLE-BIT CROSSBARS FOR BIG DIAMETER FINISH
- ZWEISCHNEIDER-BOHRSCHIENEN FÜR FEINBEARBEITUNGEN GROSSER DURCHMESSER
- BARRAS PORTA-ASIENTO DE DOS CORTES
- LES SEMELLES PORTE-LOGEMENT POUR FINISSAGE DES GRANDS DIAMÈTRES
- BARRE PORTASEGGIO PER FINITURA GRANDI DIAMETRI

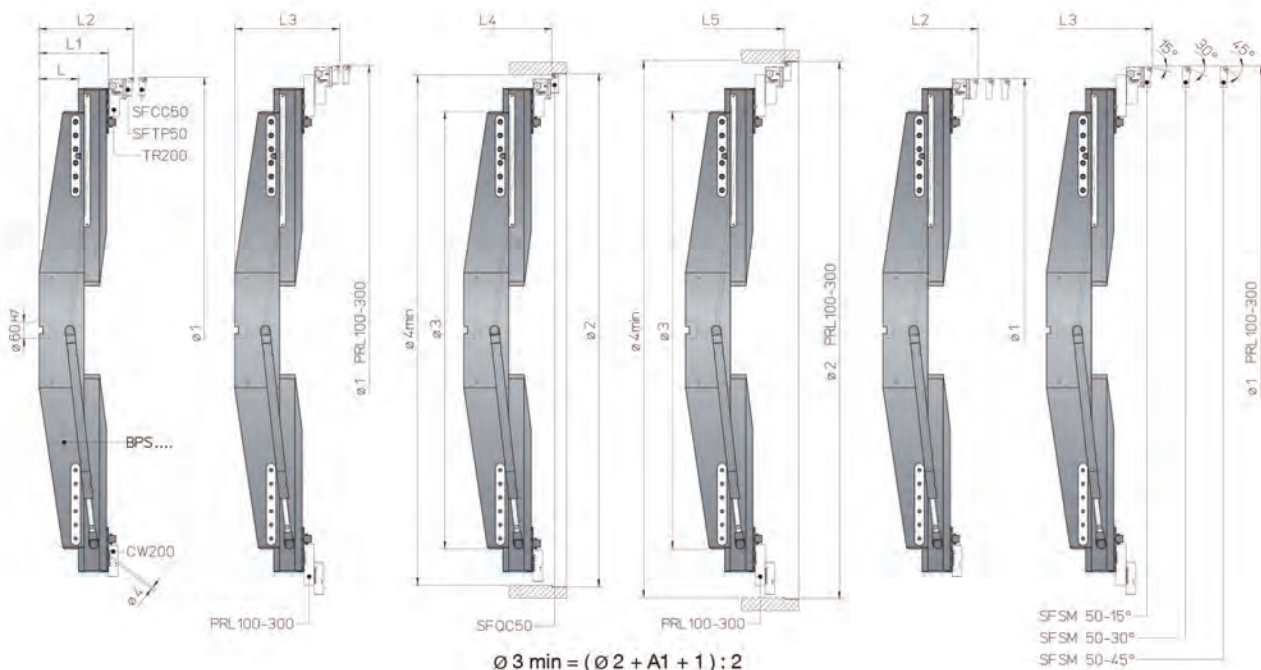

	BPS 1000	BPS 1160	BPS 1600
A	995		1595
A1	995 - 1495	1595 - 1895	1595 - 2395
B	160		200
C	150		160
Ø D1	(4xM16) 101.6		
Ø D2	-		
Ø 1	1000 - 1600	1600 - 2000	1600 - 2500
Ø 1 PRL 100	1100 - 1700	1700 - 2100	1700 - 2600
Ø 1 PRL 300	1200 - 1900	1800 - 2300	1800 - 2800
Ø 2	1002 - 1602	1602 - 2002	1602 - 2502
Ø 2 PRL 100	1102 - 1702	1702 - 2102	1702 - 2602
Ø 2 PRL 300	1202 - 1902	1802 - 2302	1802 - 2802
L	100		140
L1	191	206	246
L2	257	272	312
L3 PRL 100	287	302	342
L3 PRL 300	297	312	352
L4	240	255	295
L5 PRL 100	270	285	325
L5 PRL 300	280	295	335

D'ANDREA MODULHARD'ANDREA

BPS Ø 200 ~ 2800

- MICROMETRIC HEAD
- MIKROMETRISCHER AUSDREHKOPF
- CABEZAL MICROMÉTRICO
- TÊTE MICROMÉTRIQUE
- TESTINA MICROMETRICA

TR 200



2 µm

- | | |
|--|---|
| <p>1</p> <ul style="list-style-type: none"> • Body • Körper • Cuerpo • Corps • Corpo <p>2</p> <ul style="list-style-type: none"> • Slide toolholder • Werkzeugschlitten • Guía portaherramientas • Coulisseau • Slitta portautensili | <p>3</p> <ul style="list-style-type: none"> • Micrometric vernier scale • Mikrometrischer Nonius • Nonio micrométrico • Vernier micrométrique • Nonio micrometrico <p>4</p> <ul style="list-style-type: none"> • Slide clamp screw • Schlittenklemmschraube • Tornillo bloqueo guía • Vis blocage coulisseau • Vite bloccaggio slitta |
|--|---|

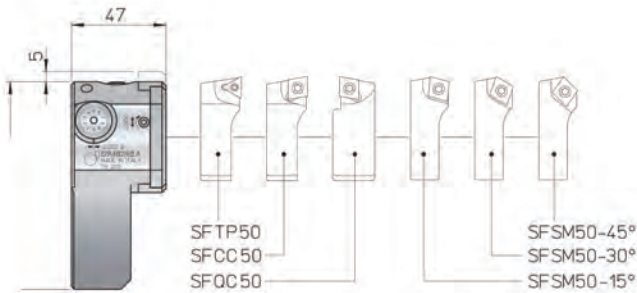

REF.	CODE	Kg.
TR 200	45 50 200 0200 0	1.3

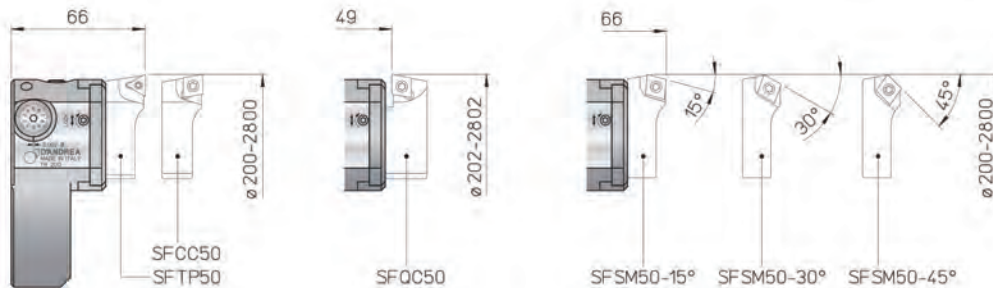

D'ANDREA

CW

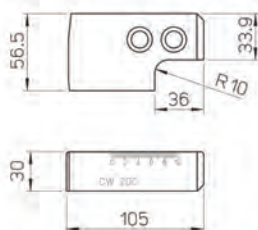

REF.	CODE	Kg.
CW 200	39 20 110 105 01	1.3

PRL

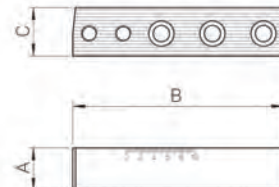

REF.	CODE	A	B	C	Kg.
PRL 100	39 20 110 155 01	31	155	35.5	1.1
PRL 300	39 20 110 300 01	41	255		2.8



BPS Ø 200 ~ 2800

- BIT-HOLDERS FOR DOUBLE-BIT ITEMS
- PLATTENHALTER FÜR ZWEISCHNEIDERWERKZEUGE
- PORTAPLAQUITAS PARA ASIENTOS A DOS CUCHILLAS
- PORTE-PLAQUETTES POUR PRODUITS À DEUX COUPANTS
- SEGGI PER BITAGLIENTI

SS-SM

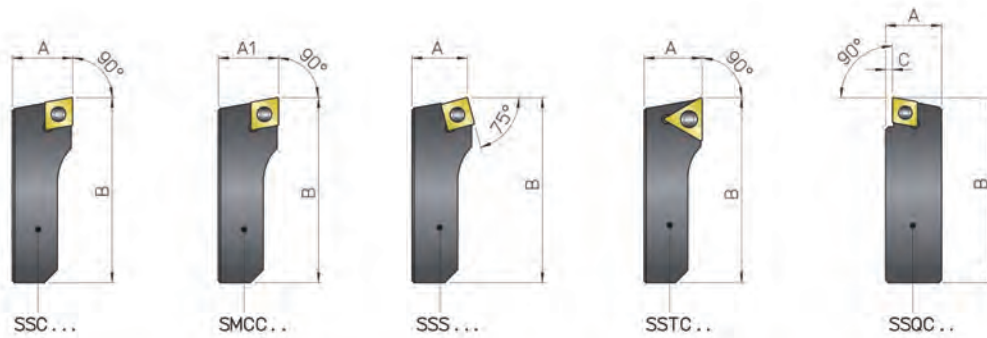

REF.	CODE	A	A1	B	C						Kg.
SSCC 90	47 050 05 90 201	32	-	130	-	CCMT 1204..	-	-	TS 5	TORX T25	0.7
SSCN 95	47 050 05 95 201	40	-	130	-	CNM. 1906..	-	-	p.152		0.9
SMCC 90	47 050 05 90 203	-	31.7	130	-	CCMT 1204..	-	-	TS 5	TORX T25	0.7
SSSC 90	47 050 05 90 202	32	-	130	-	-	SCMT 1204..	-	TS 5	TORX T25	0.7
SSSN 95	47 050 05 95 202	40	-	130	-	-	SNM . 1906..	-	p.152		0.9
SSTC 90	47 050 05 90 206	32	-	130	-	TCMT 2204..	-	-	TS 5	TORX T25	0.7
SSQC 90	47 050 05 90 261	31.5	-	122	3.5	CCMT 1204..	-	-	TS 5	TORX T25	0.8

- BIT-HOLDERS FOR TESTAROSSA
- PLATTENHALTER FÜR TESTAROSSA
- PORTA-PLAQUITAS PARA TESTAROSSA
- PORTE-PLAQUETTES POUR TESTAROSSA
- SEGGI PER TESTAROSSA

SF

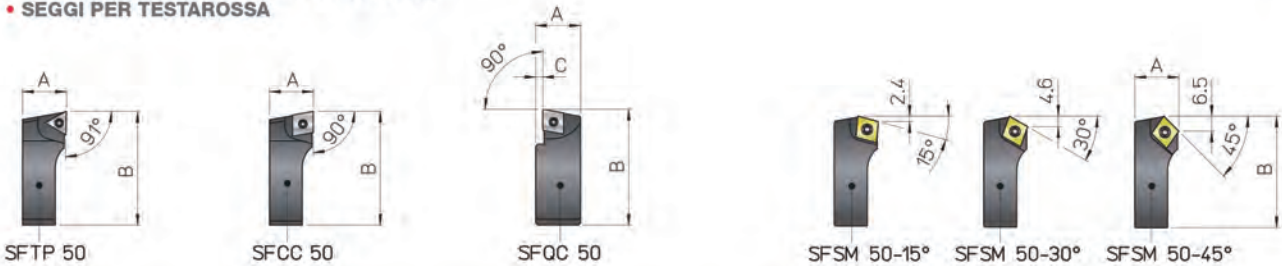

REF.	CODE	A	B	C					Kg.
SFTP 50	47 050 05 50 001	19	52	-	TPGX 1103..	-	CS 300890T	TORX T08	0.08
SFCC 50	47 050 05 50 002	19	52	-	-	CCGT 09T3..	TS 4	TORX T15	0.08
SFQC 50	47 050 05 50 062	20.5	53	3	-	CCMT 09T3..	TS 4	TORXT15	0.1
SF5M 50-15°	47 050 05 50 011	19	50.5	-	-	CCMT 09T3..	TS 4	TORXT15	0.07
SF5M 50-30°	47 050 05 50 013								
SF5M 50-45°	47 050 05 50 015								

D'ANDREA

D'ANDREA MODULHARD'ANDREA

TP Ø 100 ~ 500

- TOOLHOLDERS
- WERKZEUGHALTER
- PORTAHERRAMIENTAS
- PORTE-OUTILS
- PORTAUTENSILI



TP 80/90.50

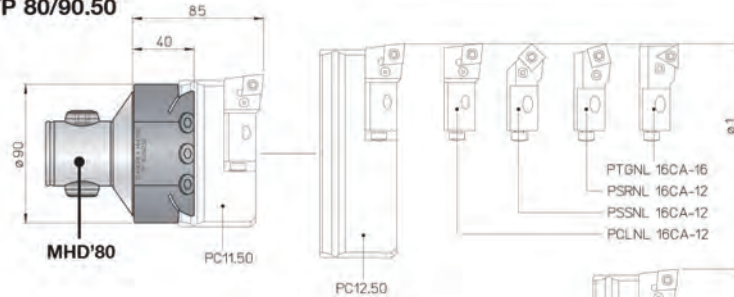

TP 80/125.50

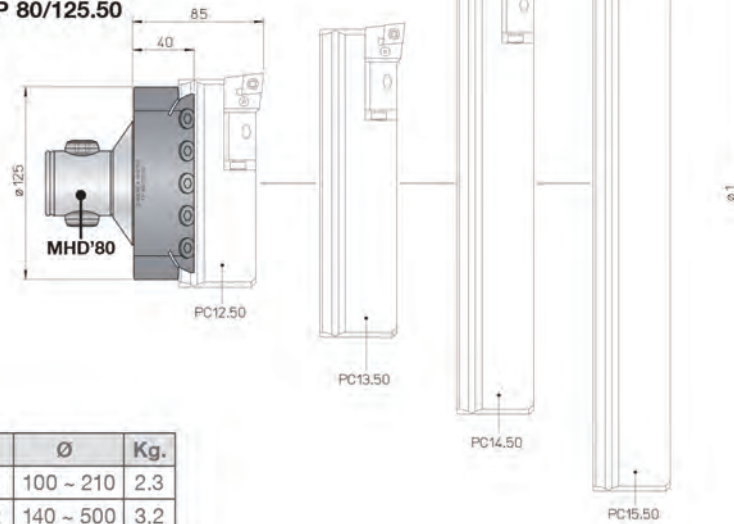

REF.	CODE	Ø	Kg.
TP 80/90.50	46 04 080 50 0 01	100 ~ 210	2.3
TP 80/125.50	46 04 080 50 0 02	140 ~ 500	3.2

PC

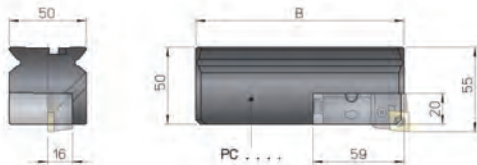

REF.	CODE	B	Ø 1 TP80/90.50	Ø 1 TP80/125.50	Kg.
PC 11.50	43 30 50 16 095 0	95	100 ~ 140	-	1.3
PC 12.50	43 30 50 16 135 0	135	140 ~ 210	140 ~ 210	2
PC 13.50	43 30 50 16 200 0	200	-	210 ~ 310	3.2
PC 14.50	43 30 50 16 300 0	300	-	310 ~ 410	4.8
PC 15.50	43 30 50 16 400 0	400	-	410 ~ 500	6.3

16CA ISO 5611

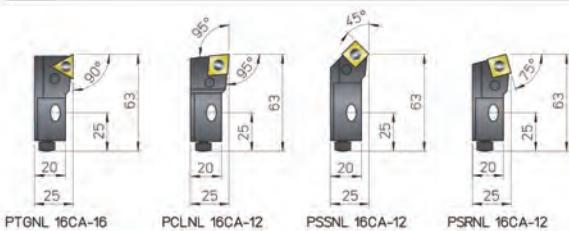

PTGNL 16CA-16 PCLNL 16CA-12 PSSNL 16CA-12 PSRNL 16CA-12

REF.	CODE	△
PTGNL 16CA-16	48 3 01 016 1 001	TNM. 1604..
PCLNL 16CA-12	48 3 01 016 1 002	CNM. 1204..
PSSNL 16CA-12	48 3 01 016 1 003	SNM. 1204..
PSRNL 16CA-12	48 3 01 016 1 004	

- On request
- Auf Anfrage
- A petición
- Sur demande
- Fornibili su richiesta



- TOOLHOLDERS
- WERKZEUGHALTER
- PORTAHERRAMIENTAS
- PORTE-OUTILS
- PORTAUTENSILI

TU

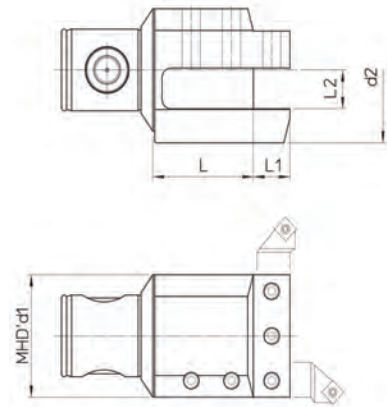

REF.	CODE	MHD* d1	d2	L	L1	L2	Kg.
TU 50/60.16	46 05 050 16 001	50	60	44	16	16	1.2
TU 63/75.20	46 05 063 20 001	63	75	55	20	20	2.4
TU 80/95.25	46 05 080 25 001	80	95	65	25	25	3.6

- CHAMFERING TOOLS
- FASRINGE
- HERRAMIENTAS PARA ACHAFLANAR
- OUTIL À CHANFREINER
- ANELLO PER SMUSSI

AS.. 45°

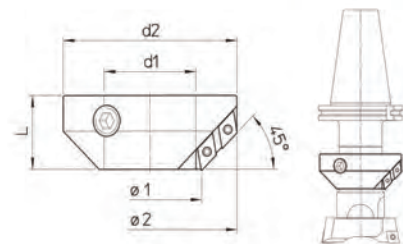

REF.	CODE	Ø1	d1	d2	L				Kg.
AS 16.45	65 56 016 0013 0	18 ~ 28	16	28	13	DCMT 0702..	TS 25	TORX T08	0.035
AS 20.45	65 56 020 0015 0	23 ~ 32	20	32	15				0.045
AS 25.45	65 56 025 0018 0	28 ~ 43	25	43	18				0.1
AS 32.45	65 56 032 0022 0	35 ~ 54	32	54	22				0.2
AS 40.45	65 56 040 0030 0	46 ~ 72	40	72	30	DCMT 11T3..	TS 4	TORX T15	0.5
AS 50.45	65 56 050 0038 0	56 ~ 95	50	95	38				1.1
AS 63.45	65 56 063 0046 0	75 ~ 125	63	125	46	DCMT 1504..	TS 5	TORX 25	2.3
AS 80.45	65 56 080 0058 0	95 ~ 165	80	165	58				5.2

D'ANDREA

- INSERTS
- WENDEPLATTEN
- PLAQUITAS
- PLAQUÉTTES
- INSERTI

WCGT ○○○○○○ L

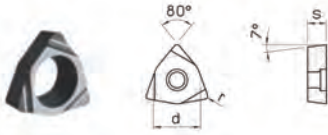

REF.	d	s	r	T	S	CARBIDE		CERMET	COATED CERMET
						DP300	DK100	DC100	DC100T
WCGT 020102 L	3.97	1.59	0.2	TS 21*-TS 211*	TORX T06	•	•	•	•
WCGT 020104 L			0.4			•	•	•	•

* TS21 : B...06
* TS211 : B...08

CCGT ○○○○○○ L

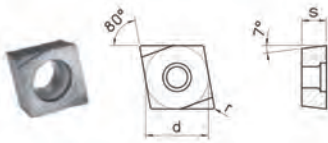

REF.	d	s	r	T	S	CARBIDE		CERMET	COATED CERMET
						DP300	DK100	DC100	DC100T
CCGT 060200 L10°	6.35	2.38	0	TS 25	TORX T08	•	•	•	•
CCGT 060202 L			0.2			•	•	•	•
CCGT 060204 L			0.4			•	•	•	•
CCGT 09T302 L	9.525	3.97	0.2	TS 4	TORX T15	•	•	•	•
CCGT 09T304 L			0.4			•	•	•	•

TPGX ○○○○○○ L

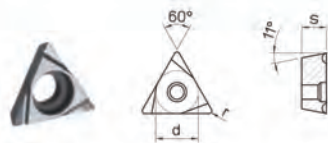

REF.	d	s	r	T	S	CARBIDE		CERMET	COATED CERMET
						DP300	DK100	DC100	DC100T
TPGX 090200 L10°	5.56	2.38	0	CS250T	TORX T08	•	•	•	•
TPGX 090202 L			0.2			•	•	•	•
TPGX 090204 L			0.4			•	•	•	•
TPGX 110300 L10°	6.35	3.18	0	CS300890T	TORX T08	•	•	•	•
TPGX 110302 L			0.2			•	•	•	•
TPGX 110304 L			0.4			•	•	•	•

TPGX ○○○○○○

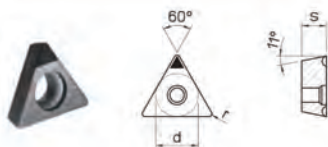

REF.	d	s	r	T	S	SINTERED DIAMOND		CUBIC BORON NITRIDE	
						D20 MDC	D20 CBN	D25 CBN	D25 CBN
TPGX 090202	5.56	2.38	0.2	CS250T	TORX T08	•	•	•	•
TPGX 090204			0.4			•	•	•	
TPGX 110302	6.35	3.18	0.2	CS300890T	TORX T08	•	•	•	•
TPGX 110304			0.4			•	•	•	•

CCMT ○○○○○○

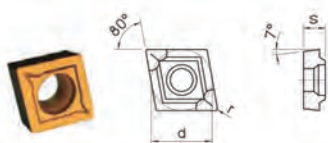

REF.	d	s	r	T	S	CARBIDE	CVD COATED CARBIDE
						DP300	DP100 R
CCMT 060202	6.35	2.38	0.2	TS 25	TORX T08	•	•
CCMT 060204			0.4			•	•
CCMT 09T304	9.525	3.97	0.4	TS 4	TORX T15	•	•
CCMT 09T308			0.8			•	•
CCMT 120404	12.7	4.76	0.4	TS 5	TORX T25	•	•
CCMT 120408			0.8			•	•



- BORING GRADE
- ÜBERSICHT AUSBOHRQUALITÄTEN
- CALIDAD DE MANDRINADO
- QUALITÉ D'ALÉSAGE
- QUALITÀ DI BARENATURA

ISO	CARBIDE HARTMETALL METAL DURO CARBURE METALLO DURO	CERMET	COATED CERMET CERMET BESCHICHTET CERMET RECUBIERTO CERMET REVÊTU CERMET RIVESTITO	CVD COATED CARBIDE HARTMETALL CVD BESCHICHTET METAL DURO RECUBIERTO CVD CARBURE REVÊTU CVD METALLO DURO RIVESTITO CVD
P01				
P10		DC100	DC100T	DP100R
P20	DP300			
P30				
P40				
K01				
K10	DK100	DC100	DC100T	DP100R
K20	DP300			
K30				

- DP300**
- Roughing and finishing. Low carbon steel - stainless steels
 - Schruppen und Schlichten. Stahl mit niedrigem Kohlenstoffgehalt - rostfreier Stahl
 - Desbaste y acabado. Aceros con bajo contenido de carbono - Aceros inoxidables
 - Ébauche et finition. Acier à bas teneur en carbon - acier inoxydable
 - Sgrossatura e finitura. Acciai a basso tenore di carbonio - acciai inox
- DK100**
- Roughing and finishing. Aluminium alloy Cast iron
 - Schruppen und Schlichten. Aluminium-Legierungen Gusseisen
 - Desbaste y acabado. Aleaciones de aluminio Fundiciones
 - Ébauche et finition. Alliage aluminium Fonte
 - Sgrossatura e finitura. Leghe di alluminio Ghise
- DP100R**
- Roughing. Steels, alloy steels and cast iron
 - Schruppen. Stahl, legierter Stahl und Gusseisen
 - Desbaste. Aceros, aceros aleados y fundiciones
 - Ébauche. Aciers, alliage acier et fonte
 - Sgrossatura. Acciai, acciai legati e ghise
- DC100**
- Finishing. Alloy steels and cast iron
 - Schlichten. Legierter Stahl und Gusseisen
 - Acabado. Aceros aleados en general y fundiciones esferoidales
 - Finition. Alliage acier et fonte ductile
 - Finitura. Acciai legati in genere e ghise sferoidali
- DC100T**
- Finishing. Alloy steels, stainless steels and cast iron
 - Schlichten. Legierter Stahl, rostfreier Stahl und Gusseisen
 - Acabado. Aceros aleados en general, aceros inoxidables y fundiciones esferoidales
 - Finition. Alliage acier, acier inoxydable et fonte ductile
 - Finitura. Acciai legati in genere, acciai inox e ghise sferoidali
- D20MDC**
- Finishing. Aluminium alloys, non-ferrous materials and non-metals
 - Schlichten. Aluminium-Legierungen, Nichteisenmetalle und nicht-metallische Materialien
 - Acabado. Aleaciones de aluminio, materiales no ferrosos y no metálicos
 - Finition. Alliage aluminium, non-ferreux et composites
 - Finitura. Leghe di alluminio, materiali non-ferrosi e non-metalli
- D20CBN**
- Finishing. High hardness steels (over 50 HRC) (it may replace the grinding)
 - Schlichten. Stahl mit Härte über 50 HRC (kann gegebenenfalls das Schleifen ersetzen)
 - Acabado. Aceros de dureza elevada superior a 50 HRC (puede sustituir el rectificado)
 - Finition. Acier à haute dureté, supérieure à 50 HRC (il peut remplacer la rectification)
 - Finitura. Acciai con elevata durezza superiore 50 HRC (può sostituire la rettifica)
- D25CBN**
- Finishing. High hardness steel (over 50 HRC) and interrupted cutting (it may replace the grinding)
 - Schlichten. Stahl mit Härte über 50 HRC und bei unterbrochenem Schnitt (kann gegebenenfalls das Schleifen ersetzen)
 - Acabado. Aceros de dureza elevada superior a 50 HRC y corte interrumpido (puede sustituir el rectificado)
 - Finition. Acier à haute dureté, supérieure à 50 HRC et coupe interrompue (il peut remplacer la rectification)
 - Finitura. Acciai con elevata durezza superiore 50 HRC e taglio interrotto (può sostituire la rettifica)

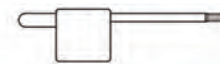
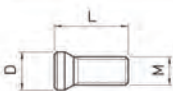

TORX

REF.	CODE	M	L	D	REF.	CODE
TS 21	49 40 1 0002034	M 2x0.4	3.7	2.7	TORX T06	10 150 09 0 0600
TS 211	49 40 1 0002040		4			
CS 250 T	49 40 1 0002565	M 2.5x0.45	6	3.7	TORX T08	10 150 09 0 0800
CS 300890 T	49 40 1 0003008	M 3x0.5	8	4.1		
TS 25	49 40 1 0002555	M 2.5x0.45	5.7	3.45		
TS 4	49 40 1 0004008	M 4x0.7	10	5.5	TORX T15	10 150 09 0 1500
TS 5	49 40 1 0005009	M 5x0.8	11.5	7	TORX T25	10 150 09 0 2500
DMC US63	49 42 1 0035070	M 3.5x0.6	10	5.2	TORX T15	10 150 09 0 1500

D'ANDREA MODULHARD'ANDREA

- RECOMMENDED CUTTING CONDITIONS FOR ROUGHING OPERATIONS WITH DOUBLE-BIT HEADS TS
- DATI DI TAGLIO CONSIGLIATI PER SGROSSATURA DI FORI CON TESTINE BITAGLIANTI TS

material materiale	boring bar dimensions dimensioni bareno	working conditions condizioni di lavoro	cutting speed $V_c = m/min.$ velocità di taglio $V_c = m/min.$			feed $f_n = mm/rev$ (twin cutters) avanzamento $f = mm/giro$ (due taglienti)		
			D < 38	diameter diametro		R = 0.2	insert radius raggio inserto	
				D = 38-120	D > 120		R = 0.4	R = 0.8
carbon steel acciaio al carbonio HB ≤ 200	L / d = 2.5	good / buona	120 - 180	140 - 200	160 - 250	-	0.2 - 0.4	0.3 - 0.5
	L / d = 4	normal / normale	100 - 160	120 - 180	140 - 200	-	0.2 - 0.4	0.3 - 0.5
	L / d = 6.3	difficult / difficile	70 - 100	70 - 100	70 - 100	0.15 - 0.3	0.2 - 0.4	-
carbon steel acciaio al carbonio HB > 200	L / d = 2.5	good / buona	100 - 160	120 - 180	140 - 200	-	0.2 - 0.4	0.3 - 0.5
	L / d = 4	normal / normale	80 - 140	100 - 160	120 - 180	-	0.2 - 0.4	0.3 - 0.5
	L / d = 6.3	difficult / difficile	60 - 90	70 - 100	70 - 100	0.15 - 0.3	0.2 - 0.4	-
stainless steel acciaio inox AISI 304 - 316	L / d = 2.5	good / buona	80 - 110	90 - 120	100 - 140	-	0.2 - 0.4	0.3 - 0.5
	L / d = 4	normal / normale	70 - 100	80 - 110	90 - 120	-	0.2 - 0.4	0.3 - 0.5
	L / d = 6.3	difficult / difficile	60 - 90	60 - 90	60 - 90	0.15 - 0.3	0.2 - 0.4	-
cast iron ghisa	L / d = 2.5	good / buona	90 - 120	100 - 140	120 - 160	-	0.2 - 0.4	0.3 - 0.5
	L / d = 4	normal / normale	70 - 100	90 - 120	100 - 140	-	0.2 - 0.4	0.3 - 0.5
	L / d = 6.3	difficult / difficile	60 - 90	60 - 90	60 - 90	0.15 - 0.3	0.2 - 0.4	-
aluminium alluminio	L / d = 2.5	good / buona	160 - 250	200 - 300	250 - 350	-	0.3 - 0.5	0.4 - 0.6
	L / d = 4	normal / normale	140 - 200	160 - 250	200 - 300	-	0.3 - 0.5	0.4 - 0.6
	L / d = 6.3	difficult / difficile	100 - 150	100 - 150	100 - 150	0.2 - 0.4	0.3 - 0.5	-



cutting depth profondità di passata ap = mm	working range campo di lavoro Ø = mm	max. cutting depth max. profondità di passata	
		steel acciaio	cast iron, aluminium ghisa, alluminio
	18 - 28	1.5 - 2	2 - 2.5
	28 - 50	2 - 3	2.5 - 3.5
	50 - 68	3 - 4	3.5 - 5
	68 - 200	4 - 5	5 - 7
	200 - 500	5 - 6	6 - 8

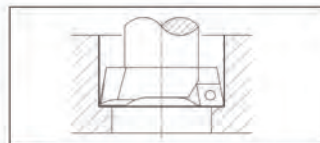

- Twin cutters at the same cutting diameter
- Due taglienti sullo stesso diametro

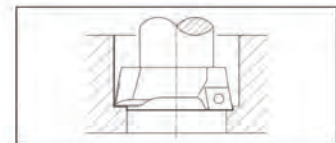

- Twin cutters at different cutting diameters
- Due taglienti su diametri diversi

- It's advisable to start with B hole ≥ the boring bar diameter d.
- È consigliabile che il preforo B sia ≥ al diametro del bareno d.

- **ATTENTION:** For boring operations at different diameters, reduce to a half the feed indicated on the above table.

- **ATTENZIONE:** Per lavorare con un solo tagliente o con differenti diametri di taglio, dimezzare l'avanzamento indicato in tabella.

- RECOMMENDED CUTTING CONDITIONS FOR BORING OPERATIONS WITH DOUBLE-BIT TESTAROSSA TRD
- DATI DI TAGLIO CONSIGLIATI PER ALESATURA CON TESTAROSSA BITAGLIANTE TRD

material materiale	boring bar dimensions dimensioni bareno	working conditions condizioni di lavoro	cutting speed $V_c = m/min.$ velocità di taglio $V_c = m/min.$	feed $f_n = mm/rev$ avanzamento $f_n = mm/giro$		quality insert qualità inserto		cutting depth profondità di passata			
				insert radius raggio inserto		roughing sgrossatura	finishing finitura	finishing finitura	roughing sgrossatura		
				R = 0.2	R = 0.4				ø28 ø46	ø46 ø75	ø75 ø120
carbon steel acciaio al carbonio HB ≤ 200	L / d = 2.5	good / buona	160 - 250	0.1 - 0.2	0.1 - 0.2	DC100 DP300	DP300 DP100R	0.15 - 0.3	1.5	2	2.5
	L / d = 4	normal / normale	120 - 180	0.1 - 0.2	0.1 - 0.2						
	L / d = 6.3	difficult / difficile	70 - 100	*0.1 - 0.15	0.1 - 0.2						
carbon steel acciaio al carbonio HB > 200	L / d = 2.5	good / buona	140 - 200	0.1 - 0.2	0.1 - 0.2	DC100	DP300 DP100R	0.15 - 0.3	1.5	2	2.5
	L / d = 4	normal / normale	100 - 160	0.1 - 0.2	0.1 - 0.2						
	L / d = 6.3	difficult / difficile	70 - 100	*0.1 - 0.15	0.1 - 0.2						
stainless steel acciaio inox AISI 304 - 316	L / d = 2.5	good / buona	100 - 140	0.1 - 0.2	0.1 - 0.2	DP300	DP300	0.15 - 0.3	1.5	2	2.5
	L / d = 4	normal / normale	80 - 110	0.1 - 0.2	0.1 - 0.2						
	L / d = 6.3	difficult / difficile	60 - 90	*0.1 - 0.15	0.1 - 0.2						
cast iron ghisa	L / d = 2.5	good / buona	120 - 160	0.1 - 0.2	0.1 - 0.2	DK100 DC300	DP100R	0.15 - 0.3	2	2.5	3
	L / d = 4	normal / normale	90 - 120	0.1 - 0.2	0.1 - 0.2						
	L / d = 6.3	difficult / difficile	60 - 90	*0.1 - 0.15	0.1 - 0.2						
aluminium alluminio	L / d = 2.5	good / buona	250 - 350	0.1 - 0.2	0.1 - 0.2	DK100	DK100	0.15 - 0.3	2	2.5	3
	L / d = 4	normal / normale	160 - 250	0.1 - 0.2	0.1 - 0.2						
	L / d = 6.3	difficult / difficile	100 - 150	*0.1 - 0.15	0.1 - 0.2						

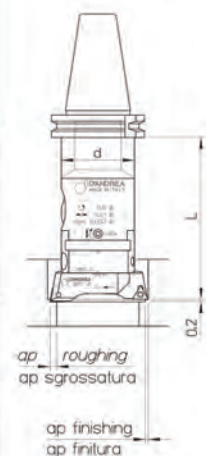

- * Only for finishing inserts
- * Solo per inserti di finitura



• RECOMMENDED CUTTING CONDITIONS FOR BORING OPERATIONS WITH TESTAROSSA TRC / TRM / TR-PSC
 • DATI DI TAGLIO CONSIGLIATI PER L'ALESATURA CON TESTAROSSA TRC / TRM / TR-PSC

material materiale	boring bar dimensions dimensioni bareno	working conditions condizioni di lavoro	cutting speed Vc= m/min. velocità di taglio Vc= m/min.	feed fn= mm/rev avanzamento fn= mm/giro			quality insert qualità inserto	cutting depth profondità di passata	
				insert radius raggio inserto					
				R = 0,0	R = 0,2	R = 0,4			
carbon steel acciaio al carbonio HB ≤ 200	L / d = 2.5	good / buona	200 - 300	-	0.05 - 0.08	0.07 - 0.1	DC100 DP300		
	L / d = 4	normal / normale	160 - 250	-	0.05 - 0.08	0.07 - 0.1			
	L / d = 6.3	difficult / difficile	70 - 100	0.05 - 0.08	0.05 - 0.08	-			
carbon steel acciaio al carbonio HB > 200	L / d = 2.5	good / buona	160 - 250	-	0.05 - 0.08	0.07 - 0.1	DC100		
	L / d = 4	normal / normale	150 - 200	-	0.05 - 0.08	0.07 - 0.1			
	L / d = 6.3	difficult / difficile	70 - 100	0.05 - 0.08	0.05 - 0.08	-			
stainless steel acciaio inox AISI 304 - 316	L / d = 2.5	good / buona	120 - 160	-	0.05 - 0.08	0.07 - 0.1	DP300		
	L / d = 4	normal / normale	100 - 140	-	0.05 - 0.08	0.07 - 0.1			
	L / d = 6.3	difficult / difficile	70 - 100	0.05 - 0.08	0.05 - 0.08	-			
cast iron ghisa	L / d = 2.5	good / buona	120 - 160	-	0.05 - 0.08	0.07 - 0.1	DK100 DC100		
	L / d = 4	normal / normale	100 - 140	-	0.05 - 0.08	0.07 - 0.1			
	L / d = 6.3	difficult / difficile	70 - 100	0.05 - 0.08	0.05 - 0.08	-			
aluminium alluminio	L / d = 2.5	good / buona	300 - 400	-	0.05 - 0.08	0.07 - 0.1	DK100		
	L / d = 4	normal / normale	250 - 350	-	0.05 - 0.08	0.07 - 0.1			
	L / d = 6.3	difficult / difficile	100 - 150	0.05 - 0.08	0.05 - 0.08	-			
steel acciaio HB ≤ 200	L / d = 2.5	good / buona	80 - 100	-	0.04 - 0.06	0.05 - 0.07	D20CBN		
	L / d = 4	normal / normale	80 - 100	-	0.04 - 0.06	0.05 - 0.07			

• CALCULATION FORMULAS FOR BORING
 • FORMULA DI CALCOLO PER ALESATURA

Vc • cutting speed (m/min.)
 • velocità di taglio (m/min.)

$$Vc = \frac{\pi \cdot D \cdot n}{1000}$$

D • diameter of workpiece (mm)
 • diametro del pezzo da lavorare (mm)

$$n = \frac{Vc \cdot 1000}{\pi \cdot D}$$

n • number of revolutions / min' (rev./min)
 • numero di giri al minuto (giri/min.)

Vf • feed rate (mm/min.)
 • velocità avanzamento (mm/min.)

$$Vf = n \cdot fn$$

fn • feed / rev. (mm/rev)
 • avanzamento al giro (mm/giro)

π • 3.14

NATIONAL TAPER SHANK

MAS 403(BT) JIS B6339

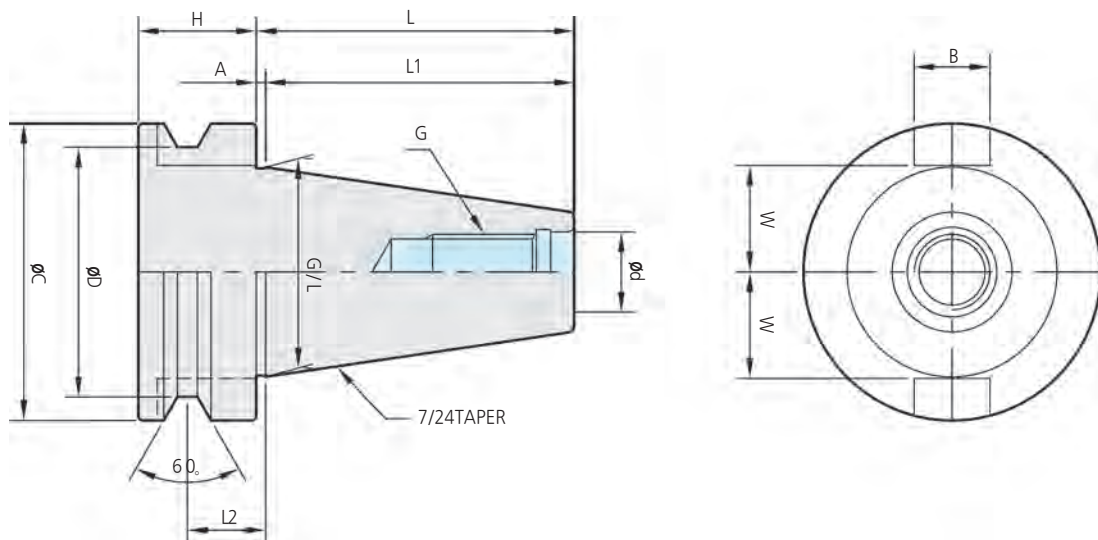

(mm)

Taper	ød	G/L	øD	L	øC	L1	L2	H	A	B	W	G
BT30	12.5	31.75	38	50.4	46	48.4	13.6	20	2	16.1	16.3	M12 x 1.75
BT40	17	44.45	53	67.4	63	65.4	16.6	25	2	16.1	22.6	M16 x 2.0
BT50	25	69.85	85	104.8	100	101.8	13.2	35	3	25.7	35.4	M24 x 3.0
BT60	31	1.7.95	135	164.8	155	161.8	28.2	45	3	25.7	60.1	M30 x 3.5

NATIONAL TAPER SHANK

DIN 2080(NT) JIS B6101

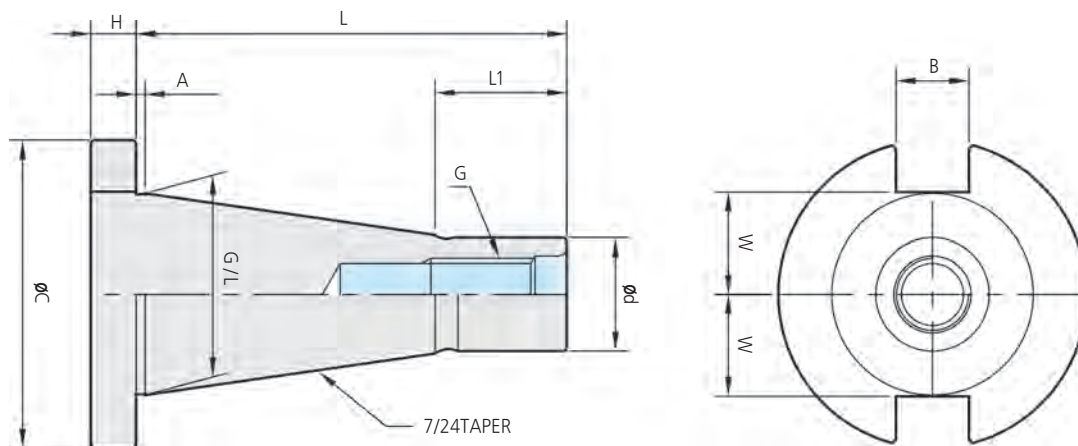

TECHNICAL

Taper	ød	G/L	L	øC	L1	H	A	B	W	G
NT30	17.4	31.75	70	46	20	10	1.6	16.1	16.2	U1/2"-13
NT40	25	44.45	95	68	29	10	1.6	16.1	22.5	U5/8"-11
NT50	39	69.85	130	98	26	15	3.2	25.7	35	U1/8
NT60	60.2	107.95	210	158	45	16	3.2	25.7	60.1	U1.1/4-7

NATIONAL TAPER SHANK

DIN69871-1A/ISO7388 SK/ISO

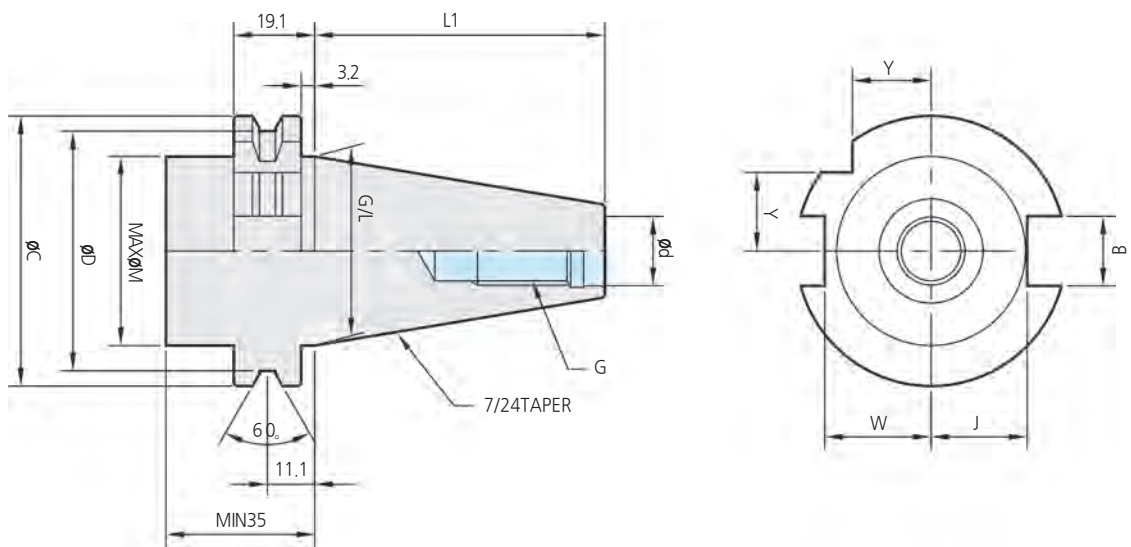

(mm)

Taper	ϕd	G/L	ϕD	ϕC	L1	ϕM	J	W	B	Y	G
SK30	13	31.75	44.3	50	47.8	75	16.4	19	16.1	15	M12*1.75
SK40	17	44.45	56.25	63.55	68.4	50	22.8	25	16.1	18.5	M16*2.0
SK50	25	69.85	91.25	97.5	101.75	80	35.5	37.7	25.7	30	M24*3.0

NATIONAL TAPER SHANK

ANSI B5,50 CATERPILLAR

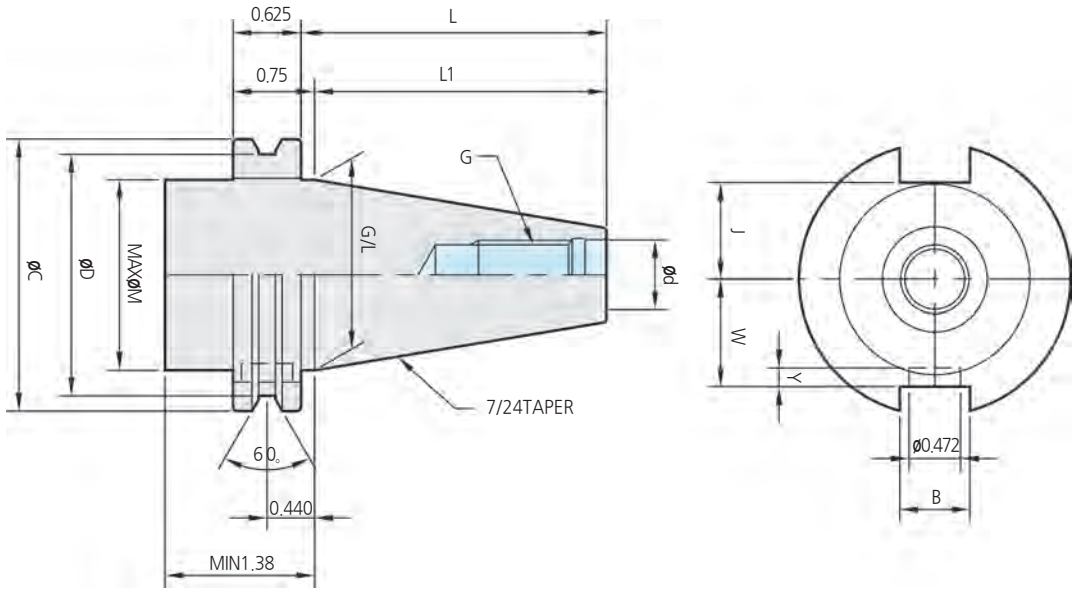

(inch)

Taper	ød	G/L	øD	L	øC	L1	øM	J	W	B	Y	G
CAT30	0.516	1.250	1.531	2.000	1.812	1.875	1.250	0.640	0.735	0.645	0.218	UNC1/2"-13
CAT40	0.641	1.750	2.219	2.812	2.5000	2.687	1.750	0.890	0.985	0.645	0.218	UNC5/8"-11
CAT50	1.031	2.750	3.594	4.125	3.874	4.000	2.750	1.390	1.485	1.020	0.343	UNC1"-8

TECHNICAL

COTTER PIN SPEC

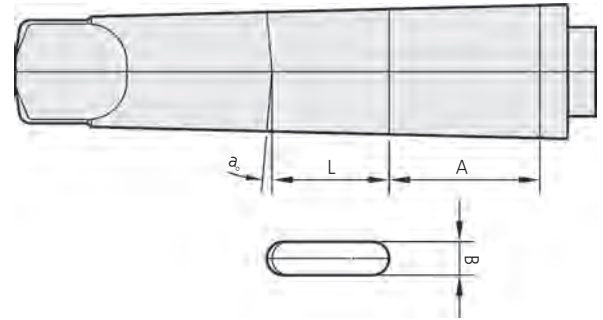

PRODUCT INFORMATION

- 대형 Endmill이나 Tapping등의 중절삭 가공시 추력의 발생으로 툴의 빠짐을 Cotter pin을 박음으로 방지가능.
- 장비 업체에 따라 Cotter pin 구멍이 다르므로 기계 회사명 및 A, B, L 치수를 알려주십시오.

- Mounting cotter pin can protect the tools drap, such as big endmill or tap due to occurring thrust in heavy duty.
- Cotter pin types are different according to machine manufacturer, please point out machine manufacturer and the size of "A", "B", "L" when you order.

Taper	Maker	Cotter Pin Code	A	L	B	a.	Machine
MT4	Aoyama	A	44	25	12.2	-	
	Yoshida	Y	10	18	8.0	-	YR3
			14	15	8.0	-	YR2
			9	21	8.0	-	YD2, YD3
	Ooya	O	5	18	8.2	-	R2000
			9	10	8.2	-	RA2-1300
			10	10	8.2	-	RE-1250A
Okuma	B	26	30	8.2	-		
Ikegai	I	33	24	10.0	8. 18'		
Kurashiki	K	26.3	28.7	12.2	5.		
MT5	Aoyama	A	48	38	13.3	5.	
	Yoshida	Y	9	31.7	13.0	5.	
	Ooya	O	22	15	12.2	-	RE2-1300
			15	20	12.2	-	RE3-1600
	Okuma	B	27	38.8	12.2	3. 30'	
	Ikegai	I	52	33	13.0	5.	
	Kurashiki	K	52	33	13.0	5.	
	Nomura	N	27	35	12.2	8. 18'	
	Shinada	S	37	37	16.0	-	
	Toshiba	T	50	35	13.0	-	
Daewoo	D	52	33	13.0	5.		
MT6	Ooya	O	25	28	19.3	-	
	Okuma	B	37	46.7	16.4	3. 30'	
	Ikegai	I	52	42	16.2	5.	
	Kurashiki	K	54	37	16.3	8. 18'	
	Nomura	N	27	37.6	16.2	8. 18'	
	Shinada	S	56.5	46	19.0	-	
	Toshiba	T	54	40	16.0	-	
	Daewoo	D	52	45	16.2	5.	
	Wia	W	54	41.3	16.2	-	

MORSE TAPER SHANK

JIS B4003

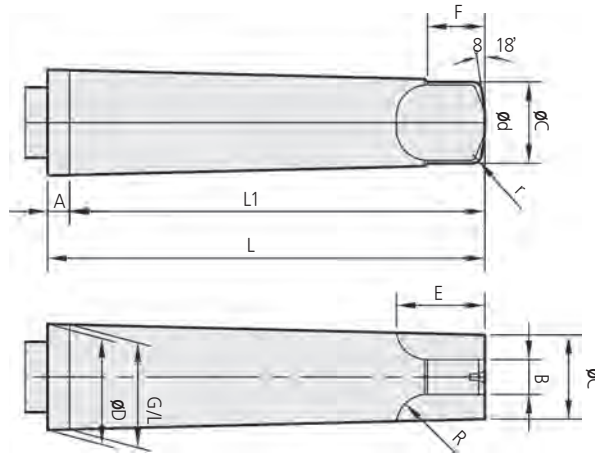

(mm)

MT No.	Taper	Angle($\alpha/2$)	G/L	ϕD	L	ϕC	L1	A	ϕd	B	E	F	R	r
MT0	1/19.212	1. 29 26.91°	9.045	9.201	59.5	6.104	56.5	3.0	6.0	3.9	10.5	6.5	6.5	1.0
MT1	1/20.047	1. 25 43.46°	12.065	12.240	65.5	8.972	62.0	3.5	8.7	5.2	13.5	8.5	8.5	1.2
MT2	1/20.020	1. 25 50.04°	17.780	18.030	80.8	14.034	75.0	5.0	13.5	6.3	16	10	10	1.6
MT3	1/19.922	1. 26 15.72°	23.825	24.076	99.0	19.107	94.0	5.0	18.5	7.9	20	13	13	2.0
MT4	1/19.254	1. 29 15.21°	31.267	31.605	124.0	25.164	117.5	6.5	24.5	11.9	24	16	16	2.5
MT5	1/19.002	1. 30 26.02°	44.399	44.741	156.0	36.531	149.5	6.5	35.7	15.9	29	19	19	3.0
MT6	1/19.180	1. 29 35.86°	63.348	63.765	218.0	52.399	210.0	8.0	51.0	19.0	40	27	27	4.0
MT7	1/19.231	1. 29 21.61°	83.058	83.578	296.0	68.186	286.0	10	66.8	28.6	54	35	35	5.0

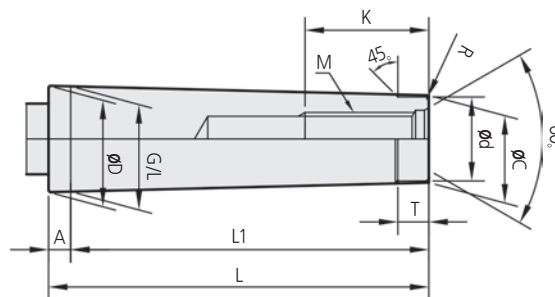

(mm)

MT No.	Taper	Angle($\alpha/2$)	G/L	ϕD	L	ϕC	L1	A	ϕd	M	K	T	R
MT0	1/19.212	1. 29 26.91°	9.045	9.201	53	6.442	50	3.0	6.0	-	6.5	4	0.3
MT1	1/20.047	1. 25 43.46°	12.065	12.240	57	9.396	53.5	3.5	9.0	M6	8.5	5	0.5
MT2	1/20.020	1. 25 50.04°	17.780	18.030	69	14.583	64	5.0	14.0	M10	10	5	0.5
MT3	1/19.922	1. 26 15.72°	23.825	24.076	86	19.759	81	5.0	19.0	M12	13	7	0.6
MT4	1/19.254	1. 29 15.21°	31.267	31.605	109	25.943	102.5	6.5	25.0	M16	16	9	1.0
MT5	1/19.002	1. 30 26.02°	44.399	44.741	136	37.584	129.5	6.5	35.7	M20	19	9	2.5
MT6	1/19.180	1. 29 35.86°	63.348	63.765	190	53.856	182	8.0	51.0	M24	27	12	4.0
MT7	1/19.231	1. 29 21.61°	83.058	83.578	260	70.058	250	10	65.0	M33	35	18.5	5.0

HSK TAPER SHANK(A-TYPE)

DIN69893-1 ISO12164-1:2001

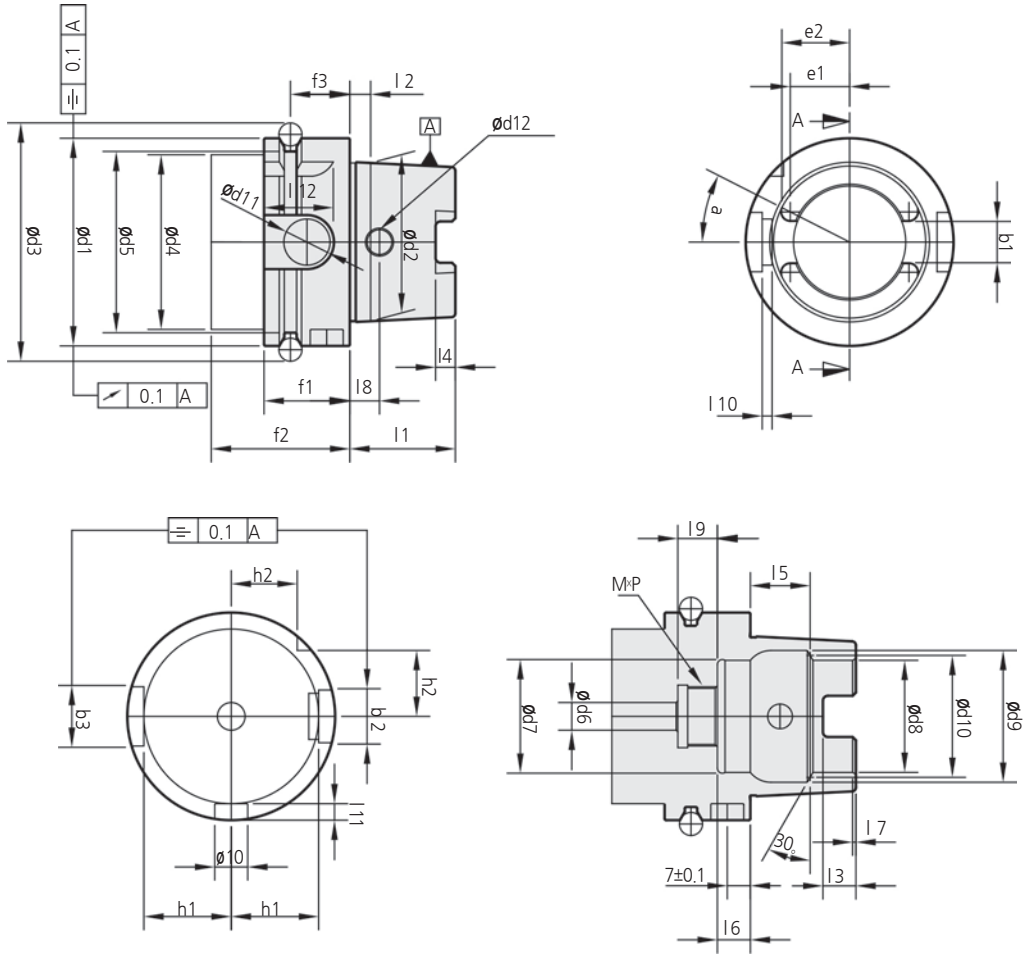

(mm)

Taper	ϕd_1	ϕd_2	ϕd_3	ϕd_4	ϕd_5	ϕd_6	ϕd_7	ϕd_8	ϕd_9	ϕd_{10}	b1	b2
HSK50	50	38.009	59.3	42	43	6.8	26.5	26	32	29	10.54	14
HSK63	63	48.010	72.3	53	55	8.4	34.5	34	40	37	12.54	18
HSK100	100	75.013	109.75	88	92	12	63.5	53	63	58	20.02	22

Taper	ϕd_3	a	e1	e2	h1	h2	f1	f2	f3	l1	l2	l3
HSK50	12	27. \pm 3	13.88	16.26	21	15.5	26	42	18	25	5	7.5
HSK63	16		17.99	20.37	26.5	20.0	26	42	18	32	6.3	10
HSK100	20		27.37	32.25	44	31.5	29	45	20	50	10	15

Taper	14	15	16	17	18	19	l10	l11	l12	$\phi 11$	ϕd_{12}	M&P
HSK50	4.5	14.13	10	1	7.5	10	2.7	5.1	19	11	6	M16*1.0
HSK63	6	18.13	10	1	9	12	2.7	5.0	21	14	7.5	M18*1.0
HSK100	10	28.56	12.5	1.5	15	16	5.2	4.9	24	16	12	M24*1.5

TECHNICAL

安全上의 注意 (Attention for Safety)

當社の製品を愛用해 주셔서 대단히 감사합니다.
 항상 製品의 品質向上 및 安全한 製品을 만들기 위하여 努力하고 있습니다.
 弊社製品의 取扱 및 使用時 下記 事項에 注意하여 주시기 바랍니다.
 Thank you very much for being used habitually our product.
 We're trying to produce safe products and quality improvement.
 Please, pay attention the following items when handle and use of our company's products.



取扱 부주의의 경우 危險한 狀況이 發生되는 경우가 있습니다.
 危險을 防止하기 위한 注意事項 이므로 取扱 說明書의 內容을 반드시 읽고 注意事項을 준수하여 作業 하여 주시기 바랍니다.
 In the case of mishandling there is occasion that critical situation is occurred.
 For preventing danger, read contents of the instructions certainly and observe and work caution.

安全上의 注意 (Safety Notice)

- ★ 製品을 들고 운반 시 BOX에서 꺼낼 때 落下에 注意하여 주십시오.
- ★ BOX가 많을 경우나 무거운 것을 取扱시는 특히 注意해 주세요. 必要에 따라서는 運搬 機具를 사용해 주십시오.
- ★ When take out from the box in process of transport. pay attention in descent.
- ★ Pay attention specially, when handle a lot of or heavy thing. if necessary, use conveyance instrument.

切削工具 取扱時 注意 (Attention at cutting tool treatment)

- ★ 切削工具는 항상 Presetter나 治具에 確實히 固定한 후 作業하여 주십시오.
- ★ 切削工具를 Holder에 끼울 때는 날부위를 손으로 直接 만지는 일이 없도록 注意하여 주십시오.
- ★ 切削工具 탈착용 工具는 지정된 工具를 사용하여 주십시오. 탈착구가 安全하게 장착 되었는지 확인 후 천천히 잠궈 주십시오. Hammer나 Pipe를 사용하여 잠그지 말아 주십시오.
- ★ Cutting tool works after fixing certainly to presetter or fixture components.
- ★ Do not to touch the edge directly with hands and pay attention when insert cutting tool to holder.
- ★ Use designated tool for desorption of cutting tool. Please lock slowly after confirmation what desorption part is inserted safe. Do not use hammer or pipe to lock.

加工時의 注意 (Attention at processing)

- ★ Holder의 回傳中에는 만지지 말아 주십시오. 다칠 수 있습니다.
- ★ 加工中에는 高熱의 切削 Chip이 튀니다. 切傷, 火傷의 염려가 있으니 安全 Cover, 保護안경을 着用해 주십시오.
- ★ 高壓 Coolant 加工의 절차시 切削工具 先端에 손이나 신체를 가까이 하지 마십시오. 誤操作의 경우 切削工具가 튀어 나갈 수 있습니다.
- ★ Holder등을 本來의 目的 이외에 使用시 改造, 分解하지 않도록 해 주십시오. 事故의 原因이 됩니다.
- ★ Please do not touch during holder's revolution. can be hurt.
- ★ Cutting chip of high temperature bounds during processing. As there is worry of incised wound and burn put safety cover and goggle.
- ★ In the case of malfunction, cutting tool can bound. Therefore, keep hands or body distance from vertical hem of cutting tool on process of high tension coolant.
- ★ Remodeling and disassembly cause and accidents.

加工時의 注意 (Attention at processing)

- ★ Chuck類을 長期間 保管하는 경우 切削工具를 分解해 保管해 주십시오. 保持力 低下의 原因이 됩니다. 만약 長期間 保管된 경우에는 Cap을 느슨하게 하고 다시 Chucking을 한 후 가공해 주십시오.
- ★ 切削 Chip은 Air로 깨끗이 불고 防滿油를 塗布하여 Taper 부분에 손상을 입지 않도록 保管해 주십시오.
- ★ 以上, 弊社製品을 使用하는데 있어 安全上의 基本的인 注意項目들이나 各製品별에 대한 注意項目은 取扱說明書에 記載되어 있습니다. 製品 使用前에 반드시 取扱說明書를 읽어 주십시오. 그 밖에 詳細한 내용은 弊社에 문의 바랍니다.
- ★ In case of keeping kinds of chuck for a long term. please classify and keep cutting tool. It cause decline of the maintenance power. If it is kept for a long term, let the cap out chuck again before processing.
- ★ Blows cutting clip cleanly by air and spreads rust preventing oil for keeping not to damage for taper segment.
- ★ The facts mentioned above are basic matters that require attention to use our company products safety. Notice of each products are in the instruction manual. before using products, read instructions certainly. for further information, please contact our compan



SELUX
NC TOOLING SYSTEM

 **SEKWANG SELUX CO., LTD.**

Head office & Factory

인천광역시 부평구 부평북로 191(청천동)
191, Bupyeongbuk-ro, Bupyeong-gu, Incheon

Changwon branch

경상남도 창원시 의창구 차상로150번길 68 (팔용동) 네오산업공구상가 A-202
A-202 NeoB/D 68, Chasang-ro 150beon-gil, Uichang-gu, Changwon-si,
Gyeongsangnam-do

Homepage. <http://www.sekwangtool.com>

Tel.82-32-676-2783. Fax.82-32-676-2784.

Email. selux@sekwangtool.com